

Massachusetts Institute of Technology

Notes for 18.721

INTRODUCTION TO ALGEBRAIC GEOMETRY

September 2020 Version

(This is a preliminary draft. Please don't reproduce.)

Especially, the exercises haven't been edited at all.

TABLE OF CONTENTS

Chapter 1: PLANE CURVES

- 1.1 The Affine Plane
- 1.2 The Projective Plane
- 1.3 Plane Projective Curves
- 1.4 Tangent Lines
- 1.5 Transcendence Degree
- 1.6 The Dual Curve
- 1.7 Resultants
- 1.8 Nodes and Cusps
- 1.9 Hensel's Lemma
- 1.10 Bézout's Theorem
- 1.11 The Plücker Formulas

Chapter 2: AFFINE ALGEBRAIC GEOMETRY

- 2.1 Rings and Modules
- 2.2 The Zariski Topology
- 2.3 Some Affine Varieties
- 2.4 The Nullstellensatz
- 2.5 The Spectrum
- 2.6 Localization
- 2.7 Morphisms of Affine Varieties
- 2.8 Finite Group Actions

Chapter 3: PROJECTIVE ALGEBRAIC GEOMETRY

- 3.1 Projective Varieties
- 3.2 Homogeneous Ideals
- 3.3 Product Varieties
- 3.4 Rational Functions
- 3.5 Morphisms and Isomorphisms
- 3.6 Affine Varieties
- 3.7 Lines in Projective Three-Space

Chapter 4: INTEGRAL MORPHISMS OF AFFINE VARIETIES

- 4.1 The Nakayama Lemma
- 4.2 Integral Extensions
- 4.3 Normalization
- 4.4 Geometry of Integral Morphisms
- 4.5 Dimension
- 4.6 Chevalley's Finiteness Theorem
- 4.7 Double Planes

Chapter 5: STRUCTURE OF VARIETIES IN THE ZARISKI TOPOLOGY

- 5.1 **Modules, review**
- 5.2 **Valuations**
- 5.3 **Smooth Curves**
- 5.4 **Constructible sets**
- 5.5 **Closed Sets**
- 5.6 **Fibred Products**
- 5.7 **Projective Varieties are Proper**
- 5.8 **Fibre Dimension**

Chapter 6: MODULES

- 6.1 **The Structure Sheaf**
- 6.2 **\mathcal{O} -Modules**
- 6.3 **The Sheaf Property**
- 6.4 **Some \mathcal{O} -Modules**
- 6.5 **Direct Image**
- 6.6 **Support**
- 6.7 **Twisting**
- 6.8 **Extending an \mathcal{O} -Module: proof**

Chapter 7: COHOMOLOGY

- 7.1 **Cohomology of \mathcal{O} -Modules**
- 7.2 **Complexes**
- 7.3 **Characteristic Properties**
- 7.4 **Construction of Cohomology**
- 7.5 **Cohomology of the Twisting Modules**
- 7.6 **Cohomology of Hypersurfaces**
- 7.7 **Three Theorems about Cohomology**
- 7.8 **Bézout's Theorem**

Chapter 8: THE RIEMANN-ROCH THEOREM FOR CURVES

- 8.1 **Branched Coverings**
- 8.2 **Divisors**
- 8.3 **The Riemann-Roch Theorem I**
- 8.4 **The Birkhoff-Grothendieck Theorem**
- 8.5 **Differentials**
- 8.6 **Trace**
- 8.7 **The Riemann-Roch Theorem II**
- 8.8 **Using Riemann-Roch**

Chapter 1 PLANE CURVES

planecurves

- 1.1 The Affine Plane
- 1.2 The Projective Plane
- 1.3 Plane Projective Curves
- 1.4 Tangent Lines
- 1.5 Transcendence Degree
- 1.6 The Dual Curve
- 1.7 Resultants and Discriminants
- 1.8 Nodes and Cusps
- 1.9 Hensel's Lemma
- 1.10 Bézout's Theorem
- 1.11 The Plücker Formulas
- 1.12 Exercises

Plane curves were the first algebraic varieties to be studied, and they provide helpful examples. So we begin with them. Chapters 2 - 7 are about varieties of arbitrary dimension. We will see in Chapter 5 how curves control higher dimensional varieties, and we come back to curves in Chapter 8.

1.1 The Affine Plane

affine-
plane

The n -dimensional *affine space* \mathbb{A}^n is the space of n -tuples of complex numbers. The *affine plane* \mathbb{A}^2 is the two-dimensional affine space.

Let $f(x_1, x_2)$ be an irreducible polynomial in two variables with complex coefficients. The set of points of the affine plane at which f vanishes, the *locus of zeros* of f , is called a *plane affine curve*. Let's denote that locus by X . Writing x for the vector (x_1, x_2) ,

affcurve

$$(1.1.1) \quad X = \{x \mid f(x) = 0\}$$

(When it seems unlikely to cause confusion, we may abbreviate the notation for an indexed set, using a single letter.)

The *degree* of the curve X is the degree of its irreducible defining polynomial f .

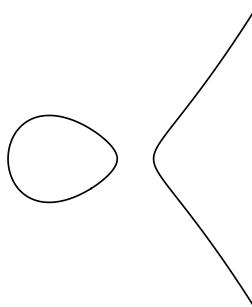

A Cubic Curve (real locus)

1.1.3. Note. In contrast with complex polynomials in one variable, most polynomials in two or more variables are *irreducible*. They cannot be factored. This can be shown by a method called “counting constants”. For instance, quadratic polynomials in x_1, x_2 depend on the six coefficients of the monomials $1, x_1, x_2, x_1^2, x_1x_2, x_2^2$ of degree at most two. Linear polynomials $ax_1 + bx_2 + c$ depend on three coefficients, but the product of two linear polynomials depends on only five parameters, because a scalar factor can be moved from one of the linear polynomials to the other. So the quadratic polynomials cannot all be written as products of linear polynomials. This reasoning is fairly convincing. It can be justified formally in terms of *dimension*, which will be discussed in Chapter 5. □

polyirred

We will get an understanding of the geometry of a plane curve as we go along, and we mention just one point here. A plane curve is called a *curve* because it is defined by one equation in two variables. Its *algebraic dimension* is one. But because our scalars are complex numbers, it will be a surface, geometrically. This is analogous to the fact that the *affine line* \mathbb{A}^1 is the plane of complex numbers.

One can see that a plane curve X is a surface by inspecting its projection to the x_1 -line. One writes the defining polynomial as a polynomial in x_2 , whose coefficients $c_i = c_i(x_1)$ are polynomials in x_1 :

$$f(x_1, x_2) = c_0x_2^d + c_1x_2^{d-1} + \dots + c_d$$

Let’s suppose that d is positive, i.e., that f isn’t a polynomial in x_1 alone.

The *fibre* of a map $V \rightarrow U$ over a point p of U is the inverse image of p – the set of points of V that map to p . The fibre of the projection $X \rightarrow \mathbb{A}^1$ over the point $x_1 = a$ is the set of points (a, b) for which b is a root of the one-variable polynomial

$$f(a, x_2) = \bar{c}_0x_2^d + \bar{c}_1x_2^{d-1} + \dots + \bar{c}_d$$

with $\bar{c}_i = c_i(a)$. There will be finitely many points in this fibre, and it won’t be empty unless $f(a, x_2)$ is a constant. So the plane curve X covers most of the x_1 -line, a complex plane, finitely often.

(1.1.4) changing coordinates

planeco-
ords

We allow linear changes of variable and translations in the affine plane \mathbb{A}^2 . When a point x is written as the column vector: $x = (x_1, x_2)^t$, the coordinates $x' = (x'_1, x'_2)^t$ after such a change of variable will be related to x by the formula

(1.1.5)
$$x = Qx' + a$$

chgcoord

where Q is an invertible 2×2 matrix with complex coefficients and $a = (a_1, a_2)^t$ is a complex translation vector. This changes a polynomial equation $f(x) = 0$, to $f(Qx' + a) = 0$. One may also multiply a polynomial f by

a nonzero complex scalar without changing the locus $\{f = 0\}$. Using these operations, all *lines*, plane curves of degree 1, become equivalent.

An *affine conic* is a plane affine curve of degree two. Every affine conic is equivalent to one of the loci

affconic (1.1.6)
$$x_1^2 - x_2^2 = 1 \quad \text{or} \quad x_2 = x_1^2$$

The proof of this is similar to the one used to classify real conics. The two loci might be called a complex 'hyperbola' and 'parabola', respectively. The complex 'ellipse' $x_1^2 + x_2^2 = 1$ becomes the 'hyperbola' when one multiplies x_2 by i .

On the other hand, there are infinitely many inequivalent cubic curves. Cubic polynomials in two variables depend on the coefficients of the ten monomials $1, x_1, x_2, x_1^2, x_1x_2, x_2^2, x_1^3, x_1^2x_2, x_1x_2^2, x_2^3$ of degree at most 3 in x . Linear changes of variable, translations, and scalar multiplication give us only seven scalars to work with, leaving three essential parameters.

1.2 The Projective Plane

projplane

The n -dimensional *projective space* \mathbb{P}^n is the set of equivalence classes of *nonzero* vectors $x = (x_0, x_1, \dots, x_n)$, the equivalence relation being

equivrel (1.2.1)
$$(x'_0, \dots, x'_n) \sim (x_0, \dots, x_n) \quad \text{if} \quad (x'_0, \dots, x'_n) = (\lambda x_0, \dots, \lambda x_n)$$

or $x' = \lambda x$, for some nonzero complex number λ . The equivalence classes are the *points* of \mathbb{P}^n , and one often refers to a point by a particular vector in its class.

Points of \mathbb{P}^n correspond bijectively to one-dimensional subspaces of the complex vector space \mathbb{C}^{n+1} . When x is a nonzero vector, the vectors λx , together with the zero vector, form the one-dimensional subspace of \mathbb{C}^{n+1} that is spanned by x .

projline

(1.2.2) the projective line

Points of the *projective line* \mathbb{P}^1 are equivalence classes of nonzero vectors (x_0, x_1) . If x_0 isn't zero, we may multiply by $\lambda = x_0^{-1}$ to normalize the first entry of (x_0, x_1) to 1, and write the point that x represents in a unique way as $(1, u)$, with $u = x_1/x_0$. There is one remaining point, the point represented by the vector $(0, 1)$. The projective line \mathbb{P}^1 can be obtained by adding this point, called the *point at infinity*, to the affine u -line, which is a complex plane. Topologically, \mathbb{P}^1 is a two-dimensional sphere.

The *projective plane* \mathbb{P}^2 is the two-dimensional projective space. Its points are equivalence classes of nonzero vectors (x_0, x_1, x_2) .

projpl

(1.2.3) lines in projective space

Let p and q be vectors that represent distinct points of projective space \mathbb{P}^n . There is a unique *line* L in \mathbb{P}^n that contains those points, the set of points $L = \{rp + sq\}$, with r, s in \mathbb{C} not both zero. The points of L correspond bijectively to points of the projective line \mathbb{P}^1 , by

pline (1.2.4)
$$rp + sq \quad \longleftrightarrow \quad (r, s)$$

A line in the projective plane \mathbb{P}^2 can also be described as the locus of solutions of a homogeneous linear equation

eqline (1.2.5)
$$s_0x_0 + s_1x_1 + s_2x_2 = 0$$

linesmeet

1.2.6. Lemma. *In the projective plane, two distinct lines have exactly one point in common, and in a projective space of any dimension, a pair of distinct points is contained in exactly one line.* \square

(1.2.7) the standard covering of \mathbb{P}^2

standcov

If the first entry x_0 of a point $p = (x_0, x_1, x_2)$ of the projective plane \mathbb{P}^2 isn't zero, we may normalize it to 1 without changing the point: $(x_0, x_1, x_2) \sim (1, u_1, u_2)$, where $u_i = x_i/x_0$. We did the analogous thing for \mathbb{P}^1 above. The representative vector $(1, u_1, u_2)$ is uniquely determined by p , so points with $x_0 \neq 0$ correspond bijectively to points of an affine plane \mathbb{A}^2 with coordinates (u_1, u_2) :

$$(x_0, x_1, x_2) \sim (1, u_1, u_2) \iff (u_1, u_2)$$

We regard the affine plane as a subset of \mathbb{P}^2 by this correspondence, and we denote that subset by \mathbb{U}^0 . The points of \mathbb{U}^0 , those with $x_0 \neq 0$, are the *points at finite distance*. The *points at infinity* of \mathbb{P}^2 are those of the form $(0, x_1, x_2)$. They are on the *line at infinity* L^0 , the locus $\{x_0 = 0\}$. The projective plane is the union of the two sets \mathbb{U}^0 and L^0 . When a point is given by a coordinate vector, we can assume that the first coordinate is either 1 or 0.

There is an analogous correspondence between points $(x_0, 1, x_2)$ and points of an affine plane \mathbb{A}^2 , and between points $(x_0, x_1, 1)$ and points of an affine plane. We denote the subsets $\{x_1 \neq 0\}$ and $\{x_2 \neq 0\}$ by \mathbb{U}^1 and \mathbb{U}^2 , respectively. The three sets $\mathbb{U}^0, \mathbb{U}^1, \mathbb{U}^2$ form the *standard covering* of \mathbb{P}^2 by three *standard affine open sets*. Since the vector $(0, 0, 0)$ has been ruled out, every point of \mathbb{P}^2 lies in at least one of the standard affine open sets. Points whose three coordinates are nonzero lie in all of them.

1.2.8. Note. Which points of \mathbb{P}^2 are at infinity depends on which of the standard affine open sets is taken to be the one at finite distance. When the coordinates are (x_0, x_1, x_2) , I like to normalize x_0 to 1, as above. Then the points at infinity are those of the form $(0, x_1, x_2)$. But when coordinates are (x, y, z) , I may normalize z to 1. Then the points at infinity are the points $(x, y, 0)$. I hope this won't cause too much confusion. \square

pointatin-
finity

(1.2.9) digression: the real projective plane

realproj-
plane

The points of the *real projective plane* $\mathbb{R}\mathbb{P}^2$ are equivalence classes of nonzero real vectors $x = (x_0, x_1, x_2)$, the equivalence relation being $x' \sim x$ if $x' = \lambda x$ for some nonzero real number λ . The real projective plane can also be thought of as the set of one-dimensional subspaces of the real vector space \mathbb{R}^3 . Let's denote \mathbb{R}^3 by V .

The plane $U : \{x_0 = 1\}$ in V is analogous to the standard affine open subset \mathbb{U}^0 in the complex projective plane \mathbb{P}^2 . We can project V from the origin $p_0 = (0, 0, 0)$ to U , sending a point $x = (x_0, x_1, x_2)$ of V distinct from p_0 to the point $(1, u_1, u_2)$, with $u_i = x_i/x_0$. The fibres of this projection are the lines through p_0 and x , with p_0 omitted.

The projection to U is undefined at the points $(0, x_1, x_2)$, which are orthogonal to the x_0 -axis. The line connecting such a point to p_0 doesn't meet U . The points $(0, x_1, x_2)$ correspond to the points at infinity of $\mathbb{R}\mathbb{P}^2$.

Looking from the origin, U becomes a "picture plane".

durerfig 1.2.10.

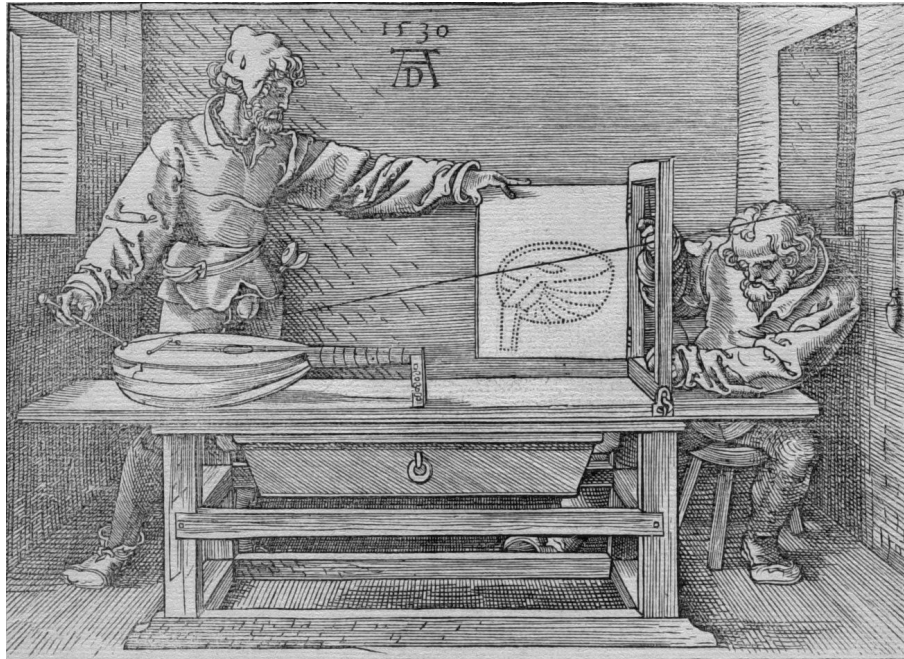

This illustration is from a book on perspective by Albrecht Dürer

The projection from 3-space to a picture plane goes back to the the 16th century, the time of Desargues and Dürer. Projective coordinates were introduced by Möbius, 200 years later.

goober4 1.2.11.

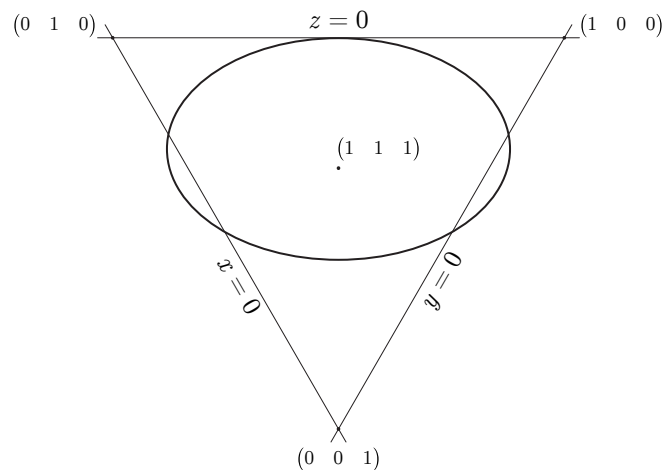

A Schematic Representation of the real Projective Plane, with a conic

This figure shows the plane $W: x+y+z = 1$ in the real vector space \mathbb{R}^3 . If $p = (x, y, z)$ is a nonzero vector, the one-dimensional subspace spanned by p will meet W in a single point, unless p is on the line $L: x+y+z = 0$. So the plane W is a faithful representation of most of \mathbb{RP}^2 . It contains all points except those on the line L .

chgco-ordssec (1.2.12) changing coordinates in the projective plane

An invertible 3×3 matrix P determines a linear change of coordinates in \mathbb{P}^2 . With $x = (x_0, x_1, x_2)^t$ and

$x' = (x'_0, x'_1, x'_2)^t$ represented as column vectors, the coordinate change is given by

$$(1.2.13) \quad Px' = x$$

chg

As the next proposition shows, four special points, points

$$e_0 = (1, 0, 0)^t, e_1 = (0, 1, 0)^t, e_2 = (0, 0, 1)^t \quad \text{and} \quad \epsilon = (1, 1, 1)^t$$

determine the coordinates.

1.2.14. Proposition. *Let p_0, p_1, p_2, q be four points of \mathbb{P}^2 , no three of which lie on a line. There is, up to scalar factor, a unique linear coordinate change $Px' = x$ such that $Pp_i = e_i$ and $Pq = \epsilon$.*

fourpoints

proof. The hypothesis that the points p_0, p_1, p_2 don't lie on a line tells us that the vectors that represent those points are independent. They span \mathbb{C}^3 . So q will be a combination $q = c_0p_0 + c_1p_1 + c_2p_2$, and because no three of the points lie on a line, the coefficients c_i will be nonzero. We can *scale* the vectors p_i (multiply them by nonzero scalars) to make $q = p_0 + p_1 + p_2$ without changing the points. Next, the columns of P can be an arbitrary set of independent vectors. We let them be p_0, p_1, p_2 . Then $Pe_i = p_i$, and $P\epsilon = q$. The matrix P is unique up to scalar factor, as can be verified by looking the reasoning over. \square

(1.2.15) conics

projconics

A polynomial $f(x_0, x_1, x_2)$ is *homogeneous of degree d* , if all monomials that appear with nonzero coefficient have (total) degree d . For example, $x_0^3 + x_1^3 - x_0x_1x_2$ is a homogeneous cubic polynomial.

A homogeneous quadratic polynomial is a combination of the six monomials

$$x_0^2, x_1^2, x_2^2, x_0x_1, x_1x_2, x_0x_2$$

A *conic* is the locus of zeros of an irreducible homogeneous quadratic polynomial.

1.2.16. Proposition. *For any conic C , there is a choice of coordinates so that C becomes the locus*

$$x_0x_1 + x_0x_2 + x_1x_2 = 0$$

classify-conic

proof. Since the conic C isn't a line, it will contain three points that aren't colinear. Let's leave the verification of this fact as an exercise. We choose three non-colinear points on C , and adjust coordinates so that they become the points e_0, e_1, e_2 . Let f be the quadratic polynomial in those coordinates whose zero locus is C . Because e_0 is a point of C , $f(1, 0, 0) = 0$, and therefore the coefficient of x_0^2 in f is zero. Similarly, the coefficients of x_1^2 and x_2^2 are zero. So f has the form

$$f = ax_0x_1 + bx_0x_2 + cx_1x_2$$

Since f is irreducible, a, b, c aren't zero. By scaling appropriately, we can make $a = b = c = 1$. We will be left with the polynomial $x_0x_1 + x_0x_2 + x_1x_2$. \square

1.3 Plane Projective Curves

projcurve

The loci in projective space that are studied in algebraic geometry are those that can be defined by systems of *homogeneous* polynomial equations. The reason for homogeneity is that the vectors (a_0, \dots, a_n) and $(\lambda a_0, \dots, \lambda a_n)$ represent the same point of \mathbb{P}^n . We want polynomial equations $\{f = 0\}$ with the property that $f(a) = 0$ if and only if $f(\lambda a) = 0$, and this will be true if and only if f is homogeneous.

To explain this, we write a polynomial $f(x_0, \dots, x_n)$ as a sum of its *homogeneous parts*:

$$(1.3.1) \quad f = f_0 + f_1 + \dots + f_d$$

homparts

where f_0 is the constant term, f_1 is the linear part, etc., and d is the degree of f .

1.3.2. Lemma. *Let f be a polynomial of degree d , and let $a = (a_0, \dots, a_n)$ be a nonzero vector. Then $f(\lambda a) = 0$ for every nonzero complex number λ if and only if $f_i(a)$ is zero for every $i = 0, \dots, d$.*

hompart-zero

proof. We have $f(\lambda x_0, \dots, \lambda x_n) = f_0 + \lambda f_1(x) + \lambda^2 f_2(x) + \dots + \lambda^d f_d(x)$. When we evaluate at some given x , the right side of this equation becomes a polynomial of degree at most d in λ . Since a nonzero polynomial of degree at most d has at most d roots, $f(\lambda x)$ won't be zero for every λ unless that polynomial is zero. \square

Thus we may as well work with homogeneous equations.

fequalsgh

1.3.3. Lemma. *If a homogeneous polynomial f is a product gh of polynomials, then g and h are homogeneous, and the zero locus $\{f = 0\}$ in projective space is the union of the two loci $\{g = 0\}$ and $\{h = 0\}$.* \square

It is also true that relatively prime homogeneous polynomials f and g have only finitely many common zeros. This isn't obvious. It will be proved below, in Proposition 1.3.11.

locipone

(1.3.4) loci in the projective line

Before going to plane curves, we describe the zero locus in the projective line \mathbb{P}^1 of a homogeneous polynomial in two variables.

factorhom-poly

1.3.5. Lemma. *Every nonzero homogeneous polynomial $f(x, y) = a_0 x^d + a_1 x^{d-1} y + \dots + a_d y^d$ with complex coefficients is a product of homogeneous linear polynomials that are unique up to scalar factor.*

To prove this, one uses the fact that the field of complex numbers is algebraically closed. A one-variable complex polynomial factors into linear factors in the polynomial ring $\mathbb{C}[y]$. To factor $f(x, y)$, one may factor the one-variable polynomial $f(1, y)$ into linear factors, substitute y/x for y , and multiply the result by x^d . When one adjusts scalar factors, one will obtain the expected factorization of $f(x, y)$. For instance, to factor $f(x, y) = x^2 - 3xy + 2y^2$, substitute $x = 1$: $2y^2 - 3y + 1 = 2(y - 1)(y - \frac{1}{2})$. Substituting $y = y/x$ and multiplying by x^2 , $f(x, y) = 2(y - x)(y - \frac{1}{2}x)$. The scalar 2 can be distributed arbitrarily among the linear factors. \square

Adjusting scalar factors, we may write a homogeneous polynomial as a product of the form

factor-polytwo

$$(1.3.6) \quad f(x, y) = (v_1 x - u_1 y)^{r_1} \cdots (v_k x - u_k y)^{r_k}$$

where no factor $v_i x - u_i y$ is a constant multiple of another, and where $r_1 + \dots + r_k$ is the degree of f . The exponent r_i is the *multiplicity* of the linear factor $v_i x - u_i y$.

A linear polynomial $vx - uy$ determines a point (u, v) in the projective line \mathbb{P}^1 , the unique *zero* of that polynomial, and changing the polynomial by a scalar factor doesn't change its zero. Thus the linear factors of the homogeneous polynomial (1.3.6) determine points of \mathbb{P}^1 , the *zeros* of f . The points (u_i, v_i) are zeros of multiplicity r_i . The total number of those points, counted with multiplicity, will be the degree of f .

The zero (u_i, v_i) of f corresponds to a root $x = u_i/v_i$ of multiplicity r_i of the one-variable polynomial $f(x, 1)$, except when the zero is the point $(1, 0)$. This happens when the coefficient a_0 of f is zero, and y is a factor of f . One could say that $f(x, y)$ has a zero at infinity in that case.

This sums up the information contained in an algebraic locus in the projective line. It will be a finite set of points with multiplicities.

intersect-line

(1.3.7) intersections with a line

Let Z be the zero locus of a homogeneous polynomial $f(x_0, \dots, x_n)$ of degree d in projective space \mathbb{P}^n , and let L be a line in \mathbb{P}^n (1.2.4). Say that L is the set of points $rp + sq$, where $p = (a_0, \dots, a_n)$ and $q = (b_0, \dots, b_n)$ are represented by specific vectors, so that L corresponds to the projective line \mathbb{P}^1 by $rp + sq \leftrightarrow (r, s)$. Let's also assume that L isn't entirely contained in the zero locus Z . The intersection $Z \cap L$ corresponds in \mathbb{P}^1 to the zero locus of the polynomial in r, s that is obtained by substituting $rp + sq$ into f . This substitution yields a homogeneous polynomial $\bar{f}(r, s)$ in r, s , of degree d . For example, let $f = x_0 x_1 + x_0 x_2 + x_1 x_2$. Then with $p = (a_0, a_1, a_2)$ and $q = (b_0, b_1, b_2)$, \bar{f} is the following quadratic polynomial in r, s :

$$\begin{aligned} \bar{f}(r, s) &= f(rp + sq) = (ra_0 + sb_0)(ra_1 + sb_1) + (ra_0 + sb_0)(ra_2 + sb_2) + (ra_1 + sb_1)(ra_2 + sb_2) \\ &= (a_0 a_1 + a_0 a_2 + a_1 a_2)r^2 + \left(\sum_{i \neq j} a_i b_j\right)rs + (b_0 b_1 + b_0 b_2 + b_1 b_2)s^2 \end{aligned}$$

The zeros of \bar{f} in \mathbb{P}^1 correspond to the points of $Z \cap L$. There will be d zeros, when counted with multiplicity.

1.3.8. Definition. With notation as above, the *intersection multiplicity* of Z and L at a point p is the multiplicity of zero of the polynomial \bar{f} . □

intersect-
linetwo

1.3.9. Corollary. Let Z be the zero locus in \mathbb{P}^n of a homogeneous polynomial f , and let L be a line in \mathbb{P}^n that isn't contained in Z . The number of intersections of Z and L , counted with multiplicity, is equal to the degree of f . □

XcapL

(1.3.10) loci in the projective plane

lociptwo

1.3.11. Proposition. Homogeneous polynomials f_1, \dots, f_r in three variables, with no common factor, have finitely many common zeros in \mathbb{P}^2 .

fgzerofi-
nite

The proof of this proposition is below. Together with Lemma 1.3.3, It shows that the most interesting type of locus in the projective plane is the zero set of a single irreducible polynomial equation.

The locus of zeros of an irreducible homogeneous polynomial f is called a *plane projective curve*. The *degree* of a plane projective curve is the degree of its irreducible defining polynomial.

1.3.12. Note. Suppose that a homogeneous polynomial is reducible, say $f = g_1 \cdots g_k$, where g_i are irreducible, and such that g_i and g_j don't differ by a scalar factor when $i \neq j$. Then the zero locus C of f is the union of the zero loci V_i of the factors g_i . In this case, C may be called a *reducible curve*.

redcurve

When there are multiple factors, say $f = g_1^{e_1} \cdots g_k^{e_k}$ and some e_i are greater than 1, it is still true that the locus $C : \{f = 0\}$ will be the union of the loci $V_i : \{g_i = 0\}$, but the connection between the geometry of C and the algebra is weakened. In this situation, the structure of a *scheme* becomes useful. We won't discuss schemes. The only situation in which we will need to keep track of multiple factors is when counting intersections with another curve D . For this purpose, one can define the *divisor* of f to be the integer combination $e_1V_1 + \cdots + e_kV_k$. □

We use the next lemma for the proof of Proposition 1.3.11. The ring $\mathbb{C}[x, y]$ embeds into its field of fractions F , which is the field of rational functions $\mathbb{C}(x, y)$ in x, y , and the polynomial ring $\mathbb{C}[x, y, z]$ is a subring of the one-variable polynomial ring $F[z]$. It can be useful to study a problem first in the principal ideal domain $F[z]$ because its algebra is simpler. Recall that the *unit ideal* of a ring R is the ring R itself.

1.3.13. Lemma. Let $F = \mathbb{C}(x, y)$ be the field of rational functions in x, y .

relprime

(i) If f_1, \dots, f_k are homogeneous polynomials in x, y, z with no common factor, their greatest common divisor in $F[z]$ is 1, and therefore they generate the unit ideal of $F[z]$. There is an equation of the form $\sum g'_i f_i = 1$ with g'_i in $F[z]$.

(ii) Let f be an irreducible polynomial in $\mathbb{C}[x, y, z]$ of positive degree in z , and a scalar multiple of z . Then f is also an irreducible element of $F[z]$.

proof. (i) Let h' be an element of $F[z]$ that isn't a unit of $F[z]$, i.e., that isn't an element of F . Suppose that, for every i , h' divides f_i in $F[z]$, say $f_i = u'_i h'$. The coefficients of h' and u'_i have denominators that are polynomials in x, y . We clear denominators from the coefficients, to obtain elements of $\mathbb{C}[x, y, z]$. This will give us equations of the form $d_i f_i = u_i h$, where d_i are polynomials in x, y and u_i and h are polynomials in x, y, z . Since h' isn't in F , neither is h . So h will have positive degree in z . Let g be an irreducible factor of h of positive degree in z . Then g divides $d_i f_i$ but doesn't divide d_i which has degree zero in z . So g divides f_i , and this is true for every i . This contradicts the hypothesis that f_1, \dots, f_k have no common factor.

(ii) Say that $f(x, y, z)$ factors in $F[z]$, $f = g' h'$, where g' and h' are polynomials of positive degree in z with coefficients in F . When we clear denominators from g' and h' , we obtain an equation of the form $df = gh$, where g and h are polynomials in x, y, z of positive degree in z and d is a polynomial in x, y . Neither g nor h divides d , so f must be reducible. □

proof of Proposition 1.3.11. We are to show that homogeneous polynomials f_1, \dots, f_r in x, y, z with no common factor have finitely many common zeros. Lemma 1.3.13 tells us that we may write $\sum g'_i f_i = 1$, with g'_i in $F[z]$. Clearing denominators from g'_i gives us an equation of the form

$$\sum g_i f_i = d$$

where g_i are polynomials in x, y, z and d is a polynomial in x, y . Taking suitable homogeneous parts of g_i and d produces an equation $\sum g_i f_i = d$ in which all terms are homogeneous.

Lemma 1.3.5 asserts that d is a product of linear polynomials, say $d = \ell_1 \cdots \ell_r$. A common zero of f_1, \dots, f_k is also a zero of d , and therefore it is a zero of ℓ_j for some j . It suffices to show that, for every j , f_1, \dots, f_r and ℓ_j have finitely many common zeros.

Since f_1, \dots, f_k have no common factor, there is at least one f_i that isn't divisible by ℓ_j . Corollary 1.3.9 shows that f_i and ℓ_j have finitely many common zeros. Therefore f_1, \dots, f_k and ℓ_j have finitely many common zeros for every j . \square

1.3.14. Corollary. *Every locus in the projective plane \mathbb{P}^2 that can be defined by a system of homogeneous polynomial equations is a finite union of points and curves.* \square

The next corollary is a special case of the Strong Nullstellensatz, which will be proved in the next chapter.

1.3.15. Corollary. *Let f be an irreducible homogeneous polynomial in three variables, that vanishes on an infinite set S of points of \mathbb{P}^2 . If another homogeneous polynomial g vanishes on S , then f divides g . Therefore, if an irreducible polynomial vanishes on an infinite set S , that polynomial is unique up to scalar factor.*

proof. If the irreducible polynomial f doesn't divide g , then f and g have no common factor, and therefore they have finitely many common zeros. \square

(1.3.16) the classical topology

The usual topology on the affine space \mathbb{A}^n will be called the *classical topology*. A subset U of \mathbb{A}^n is open in the classical topology if, whenever U contains a point p , it contains all points sufficiently near to p . We call this the classical topology to distinguish it from another topology, the *Zariski topology*, which will be discussed in the next chapter.

The projective space \mathbb{P}^n also has a classical topology. A subset U of \mathbb{P}^n is open if, whenever a point p of U is represented by a vector (x_0, \dots, x_n) , all vectors $x' = (x'_0, \dots, x'_n)$ sufficiently near to x represent points of U .

(1.3.17) isolated points

A point p of a topological space X is *isolated* if both $\{p\}$ and its complement $X - \{p\}$ are closed sets, or if $\{p\}$ is both open and closed. If X is a subset of \mathbb{A}^n or \mathbb{P}^n , a point p of X is isolated in the classical topology if X doesn't contain points p' distinct from p , but arbitrarily close to p .

1.3.18. Proposition *Let n be an integer greater than one. In the classical topology, the zero locus of a polynomial in \mathbb{A}^n or in \mathbb{P}^n contains no isolated points.*

1.3.19. Lemma. *Let f be a polynomial of degree d in n variables. After a suitable coordinate change, $f(x)$ will become a monic polynomial of degree d in the variable x_n .*

proof. We write $f = f_0 + f_1 + \cdots + f_d$, where f_i is the homogeneous part of f of degree i , and we choose a point p of \mathbb{A}^n at which f_d isn't zero. We change variables so that p becomes the point $(0, \dots, 0, 1)$ (see (1.1.4)). We call the new variables x_1, \dots, x_n and the new polynomial f . Then $f_d(0, \dots, 0, x_n)$ will be equal to $c x_n^d$ for some nonzero constant c . When we adjust by a scalar factor to make $c = 1$, f will be monic. \square

proof of Proposition 1.3.18. The proposition is true for loci in affine space and also for loci in projective space. We look at the affine case. Let $f(x_1, \dots, x_n)$ be a polynomial with zero locus Z , and let p be a point of Z . We adjust coordinates so that p is the origin $(0, \dots, 0)$ and f is monic in x_n . We relabel x_n as y , and write f as a polynomial in y . Let's write $f(x, y) = \tilde{f}(y)$:

$$\tilde{f}(y) = f(x, y) = y^d + c_{d-1}(x)y^{d-1} + \cdots + c_0(x)$$

where c_i is a polynomial in x_1, \dots, x_{n-1} . For fixed x , $c_0(x)$ is the product of the roots of $\tilde{f}(y)$. Since p is the origin and $f(0) = 0$, $c_0(0) = 0$. So $c_0(x)$ will tend to zero with x . When $c_0(x)$ is small, at least one root y of $\tilde{f}(y)$ will be small. So there are points of Z that are arbitrarily close to p . \square

1.3.20. Corollary. Let C' be the complement of a finite set of points in a plane curve C . In the classical topology, a continuous function g on C that is zero at every point of C' is identically zero. \square

function-
iszero

1.4 Tangent Lines

(1.4.1) working locally

tanlines
standnot

We will often want to inspect a plane projective curve $C : \{f(x_0, x_1, x_2) = 0\}$ in a neighborhood of a particular point p . To do this we may adjust coordinates so that p becomes the point $(1, 0, 0)$, and work with points $(1, x_1, x_2)$ in the standard affine open set $\mathbb{U}^0 : \{x_0 \neq 0\}$. Identifying \mathbb{U}^0 with the affine x_1, x_2 -plane, p becomes the origin, and C becomes the zero locus of the nonhomogeneous polynomial $f(1, x_1, x_2)$.

Of course, it doesn't matter which variable we set to 1. If the variables are x, y, z , we may prefer to take for p the point $(0, 0, 1)$ and work with the polynomial $f(x, y, 1)$. This will be a standard notation for working locally.

Similarly, if we are looking at an affine plane curve $f(x_1, x_2) = 0$, we may choose coordinates so that p becomes the origin.

1.4.2. Lemma. A homogeneous polynomial $f(x_0, x_1, x_2)$ that isn't divisible by x_0 is irreducible if and only if its dehomogenization $f(1, x_1, x_2)$ is irreducible. \square

foneirred

(1.4.3) homogenizing and dehomogenizing

homde-
homone

If $f(x_0, x_1, x_2)$ is a homogeneous polynomial, $f(1, x_1, x_2)$ is called the *dehomogenization* of f with respect to the variable x_0 .

A simple procedure, *homogenization*, inverts dehomogenization. Suppose given a nonhomogeneous polynomial $F(x_1, x_2)$ of degree d . To homogenize F , we replace the variables x_i , $i = 1, 2$, by $u_i = x_i/x_0$. Then since u_i have degree zero in x , so does $F(u_1, u_2)$. When we multiply by x_0^d , the result will be a homogeneous polynomial of degree d in x_0, x_1, x_2 that isn't divisible by x_0 ,

We will come back to homogenization in Chapter 3.

(1.4.4) smooth points and singular points

smsingpts

Let C be the plane curve defined by an irreducible homogeneous polynomial $f(x_0, x_1, x_2)$, and let f_i denote the partial derivative $\frac{\partial f}{\partial x_i}$, which are computed by the usual calculus formula. A point of C at which the partial derivatives f_i aren't all zero is called a *smooth point* of C , and a point at which all partial derivatives are zero is a *singular point*. A curve is *smooth*, or *nonsingular*, if it contains no singular point; otherwise it is a *singular curve*.

The *Fermat curve*

$$(1.4.5) \quad x_0^d + x_1^d + x_2^d = 0$$

fer-
matcurve

is smooth because the only common zero of the partial derivatives $dx_0^{d-1}, dx_1^{d-1}, dx_2^{d-1}$, which is $(0, 0, 0)$, doesn't represent a point of \mathbb{P}^2 . The cubic curve $x_0^3 + x_1^3 - x_0x_1x_2 = 0$ is singular at the point $(0, 0, 1)$.

The Implicit Function Theorem explains the meaning of smoothness. Suppose that $p = (1, 0, 0)$ is a point of C . We set $x_0 = 1$ and inspect the locus $f(1, x_1, x_2) = 0$ in the standard affine open set \mathbb{U}^0 . If $f_2(p)$ isn't zero, the Implicit Function Theorem tells us that we can solve the equation $f(1, x_1, x_2) = 0$ for x_2 locally (i.e., for small x_1) as an analytic function φ of x_1 , with $\varphi(0) = 0$. Sending x_1 to $(1, x_1, \varphi(x_1))$ inverts the projection from C to the affine x_1 -line, locally. So at a smooth point, C is locally homeomorphic to the affine line.

1.4.6. Euler's Formula. Let f be a homogeneous polynomial of degree d in the variables x_0, \dots, x_n . Then

eulerfor-
mula

$$\sum_i x_i \frac{\partial f}{\partial x_i} = d f.$$

To prove this, it is enough to check the formula when f is a monomial. As an example, let f be the monomial x^2y^3z , then

$$xf_x + yf_y + zf_z = x(2xy^3z) + y(3x^2y^2z) + z(x^2y^3) = 6x^2y^3z = 6f \quad \square$$

sing-
pointon-
curve

1.4.7. Corollary. (i) *If all partial derivatives of an irreducible homogeneous polynomial f are zero at a point p of \mathbb{P}^2 , then f is zero at p , and therefore p is a singular point of the curve $\{f = 0\}$.*

(ii) *At a smooth point of a plane curve, at least two partial derivatives will be nonzero.*

(iii) *The partial derivatives of an irreducible polynomial have no common (nonconstant) factor.*

(iv) *A plane curve has finitely many singular points.* □

tangent

(1.4.8) tangent lines and flex points

Let C be the plane projective curve defined by an irreducible homogeneous polynomial f . A line L is *tangent* to C at a smooth point p of C if the intersection multiplicity of C and L at p is at least 2. (See (1.3.8).)

A smooth point p of C is a *flex point* if the intersection multiplicity of C and its tangent line at p is at least 3, and p is an *ordinary flex point* if the intersection multiplicity is equal to 3.

Let L be a line through a point p and let q be a point of L distinct from p . We represent p and q by specific vectors (p_0, p_1, p_2) and (q_0, q_1, q_2) , to write a variable point of L as $p + tq$, and we expand the restriction of f to L in a Taylor's Series. (The Taylor expansion carries over to complex polynomials because it is an identity.)

Let $f_i = \frac{\partial f}{\partial x_i}$ and $f_{ij} = \frac{\partial^2 f}{\partial x_i \partial x_j}$. Then

taylor (1.4.9)
$$f(p + tq) = f(p) + \left(\sum_i f_i(p) q_i \right) t + \frac{1}{2} \left(\sum_{i,j} q_i f_{ij}(p) q_j \right) t^2 + O(3)$$

where the symbol $O(3)$ stands for a polynomial in which all terms have degree at least 3 in t . The point q is missing from this parametrization, but this won't be important.

We rewrite the equation: Let ∇ be the *gradient vector* (f_0, f_1, f_2) , let H be the *Hessian matrix* of f , the matrix of second partial derivatives:

hessian-
matrix

(1.4.10)
$$H = \begin{pmatrix} f_{00} & f_{01} & f_{02} \\ f_{10} & f_{11} & f_{12} \\ f_{20} & f_{21} & f_{22} \end{pmatrix}$$

and let ∇_p and H_p be the evaluations of ∇ and H , respectively, at p . So p is a smooth point of C if $f(p) = 0$ and $\nabla_p \neq 0$. Regarding p and q as column vectors, Equation 1.4.9 can be written as

texp (1.4.11)
$$f(p + tq) = f(p) + (\nabla_p q) t + \frac{1}{2} (q^t H_p q) t^2 + O(3)$$

in which $\nabla_p q$ and $q^t H_p q$ are computed as matrix products.

The intersection multiplicity of C and L at p (1.3.8) is the lowest power of t that has nonzero coefficient in $f(p + tq)$. The intersection multiplicity is at least 1 if p lies on C , i.e., if $f(p) = 0$. If p is a smooth point of C , then L is tangent to C at p if the coefficient $(\nabla_p q)$ of t is zero, and p is a flex point if $(\nabla_p q)$ and $(q^t H_p q)$ are both zero.

The equation of the tangent line L at a smooth point p is $\nabla_p x = 0$, or

tanlineeq

(1.4.12)
$$f_0(p)x_0 + f_1(p)x_1 + f_2(p)x_2 = 0$$

which tells us that a point q lies on L if the linear term in t of (1.4.11) is zero. Thus there is a unique tangent line at a smooth point.

Taylor's formula shows that the restriction of f to every line through a singular point has a multiple zero. However, we will speak of tangent lines only at smooth points of the curve.

The next lemma can be obtained by applying Euler's Formula to the entries of H_p and ∇_p .

1.4.13. Lemma. $\nabla_p p = d f(p)$ and $p^t H_p = (d - 1) \nabla_p$. □ applyeuler

We will rewrite Equation 1.4.9 one more time, using the notation $\langle u, v \rangle$ to represent the symmetric bilinear form $u^t H_p v$ on $V = \mathbb{C}^3$. It makes sense to say that this form vanishes on a pair of points of \mathbb{P}^2 , because the condition $\langle u, v \rangle = 0$ doesn't depend on the vectors that represent those points.

1.4.14. Proposition. *With notation as above,* linewith-
form

(i) Equation (1.4.9) can be written as

$$f(p + tq) = \frac{1}{d(d-1)} \langle p, p \rangle + \frac{1}{d-1} \langle p, q \rangle t + \frac{1}{2} \langle q, q \rangle t^2 + O(3)$$

(ii) A point p is a smooth point of C if and only if $\langle p, p \rangle = 0$ but $\langle p, v \rangle$ isn't identically zero.

proof. (i) This follows from Lemma 1.4.13.

(ii) At a smooth point p , $\langle p, v \rangle = (d - 1) \nabla_p v$ isn't identically zero because ∇_p isn't zero. □

1.4.15. Corollary. *Let p be a smooth point of C , let q be a point of \mathbb{P}^2 distinct from p . and let L be the line through p and q . Then* bilinearform

(i) L is tangent to C at p if and only if $\langle p, p \rangle = \langle p, q \rangle = 0$, and

(ii) p is a flex point of C with tangent line L if and only if $\langle p, p \rangle = \langle p, q \rangle = \langle q, q \rangle = 0$. □

1.4.16. Theorem. *A smooth point p of the curve C is a flex point if and only if the determinant $\det H_p$ of the Hessian matrix at p is zero.* tangent-
line

proof. Let p be a smooth point of C , so that $\langle p, p \rangle = 0$. If $\det H_p = 0$, the form $\langle u, v \rangle$ is degenerate, and there is a nonzero null vector q . Then $\langle p, q \rangle = \langle q, q \rangle = 0$. But p isn't a null vector, because $\langle p, v \rangle$ isn't identically zero. So q is distinct from p . Therefore p is a flex point.

Conversely, suppose that p is a flex point and let q be a point on the tangent line at p and distinct from p , so that $\langle p, p \rangle = \langle p, q \rangle = \langle q, q \rangle = 0$. The restriction of the form to the two-dimensional space W spanned by p and q is zero, and this implies that the form is degenerate. If (p, q, v) is a basis of V with p, q in W , the matrix of the form will look like this:

$$\begin{pmatrix} 0 & 0 & * \\ 0 & 0 & * \\ * & * & * \end{pmatrix} \quad \square$$

1.4.17. Proposition. hess-
notzero

(i) Let $f(x, y, z)$ be an irreducible homogeneous polynomial of degree at least two. The **Hessian determinant** $\det H$ isn't divisible by f . In particular, the Hessian determinant isn't identically zero.

(ii) A curve that isn't a line has finitely many flex points.

proof. (i) Let C be the curve defined by f . If f divides the Hessian determinant, every smooth point of C will be a flex point. We set $z = 1$ and look on the standard affine \mathbb{U}^2 , choosing coordinates so that the origin p is a smooth point of C , and so that $\frac{\partial f}{\partial y} \neq 0$ at p . The Implicit Function Theorem tells us that we can solve the equation $f(x, y, 1) = 0$ for y locally, say $y = \varphi(x)$, for some analytic function φ . The graph $\Gamma : \{y = \varphi(x)\}$ will be equal to C in a neighborhood of p (see below). A point of Γ is a flex point if and only if $\frac{d^2 \varphi}{dx^2}$ is zero there. If this is true for all points near to p , then $\frac{d^2 \varphi}{dx^2}$ will be identically zero, and this implies that φ is linear: $y = ax$. Then $y = ax$ solves $f = 0$, and therefore $y - ax$ divides $f(x, y, 1)$. But $f(x, y, z)$ is irreducible, and so is $f(x, y, 1)$. Therefore $f(x, y, 1)$ is linear, and so is $f(x, y, z)$, contrary to hypothesis.

(ii) This follows from (i) and (1.3.11). The irreducible polynomial f and the Hessian determinant $\det H$ have finitely many common zeros. □

1.4.18. Review. *(about the Implicit Function Theorem)* ifthm

By analytic function $\varphi(x_1, \dots, x_k)$, in one or more variables, we mean a complex-valued function that can be represented as a convergent power series for small x . Most often, φ will be a function of one variable.

Let $f(x, y)$ be a polynomial of two variables, such that $f(0, 0) = 0$ and $\frac{df}{dy}(0, 0) \neq 0$. The Implicit Function Theorem asserts that there is a unique analytic function $\varphi(x)$ such that $\varphi(0) = 0$ and $f(x, \varphi(x))$ is identically zero. Let \mathcal{R} be the ring of analytic functions in x . In the polynomial ring $\mathcal{R}[\dagger]$, polynomial $y - \varphi(x)$, which is monic in y , divides $f(x, y)$. To see this, we do division with remainder of f by $y - \varphi(x)$:

divrem (1.4.19)
$$f(x, y) = (y - \varphi(x))q(x, y) + r(x)$$

The quotient q and remainder r are in $\mathcal{R}[y]$, and $r(x)$ has degree zero in y , so it is in \mathcal{R} . Setting $y = \varphi(x)$ in the equation, one sees that $r(x) = 0$.

Let Γ be the graph of φ in a suitable neighborhood U of the origin in x, y -space. Since $f(x, y) = (y - \varphi(x))q(x, y)$, the locus $f(x, y) = 0$ in U has the form $\Gamma \cup \Delta$, where Γ is the zero locus of $y - \varphi(x)$ and Δ is the zero locus of $q(x, y)$. Differentiating, we find that $\frac{\partial f}{\partial y}(0, 0) = q(0, 0)$. So $q(0, 0) \neq 0$. Then Δ doesn't contain the origin, while Γ does. This implies that Δ is disjoint from Γ , locally. A sufficiently small neighborhood U of the origin won't contain any points of Δ . In such a neighborhood, the locus of zeros of f will be Γ . \square

1.5 Transcendence Degree

transcdeg

Let $F \subset K$ be a field extension. A set $\alpha = \{\alpha_1, \dots, \alpha_n\}$ of elements of K is *algebraically dependent over F* if there is a nonzero polynomial $f(x_1, \dots, x_n)$ with coefficients in F , such that $f(\alpha) = 0$. If there is no such polynomial, the set α is *algebraically independent over F* .

An infinite set is called algebraically independent if every finite subset is algebraically independent, in other words, if there is no polynomial relation among any finite set of its elements.

The set $\{\alpha_1\}$ consisting of a single element of K will be algebraically dependent if α_1 is algebraic over F . Otherwise, it will be algebraically independent, and then α_1 is said to be *transcendental over F* .

An algebraically independent set $\alpha = \{\alpha_1, \dots, \alpha_n\}$ that isn't contained in a larger algebraically independent set is a *transcendence basis* for K over F . If there is a finite transcendence basis, its order is the *transcendence degree* of the field extension K of F . Lemma 1.5.3 below shows that all transcendence bases for K over F have the same order, so the transcendence degree is well-defined. If there is no finite transcendence basis, the transcendence degree of K over F is infinite.

For example, let $K = F(x_1, \dots, x_n)$ be the field of rational functions in n variables. The variables x_i form a transcendence basis of K over F , and the transcendence degree of K over F is n .

A *domain* is a nonzero ring with no zero divisors, and a domain that contains a field F as a subring is called an *F -algebra*. Because \mathbb{C} -algebras occur frequently, we refer to them simply as *algebras*.

trdegalg

1.5.1. Proposition. *Suppose that an algebra A is a domain, and let K be its fraction field. If K has transcendence degree n , then every algebraically independent set of elements of A is contained in an algebraically independent subset of A of order n .*

This proposition shows that one can speak of the transcendence degree of an algebra that is a domain. It will be equal to the transcendence degree of its field of fractions.

We use the customary notation $F[\alpha_1, \dots, \alpha_n]$ or $F[\alpha]$ for the F -algebra generated by a set $\alpha = \{\alpha_1, \dots, \alpha_n\}$, and we may denote its field of fractions by $F(\alpha_1, \dots, \alpha_n)$ or by $F(\alpha)$.

proof of Proposition 1.5.1. We let a_1, \dots, a_k be a maximal algebraically independent set of elements of A . Then every element of A will be algebraic over the field $F = \mathbb{C}(a_1, \dots, a_k)$, and therefore K will be algebraic over F , so $k = n$. \square

The set $\{\alpha_1, \dots, \alpha_n\}$ is algebraically independent over F if and only if the surjective map from the polynomial algebra $F[x_1, \dots, x_n]$ to $F[\alpha_1, \dots, \alpha_n]$ that sends x_i to α_i is bijective.

algindtrivialities

1.5.2. Lemma. *Let K/F be a field extension, let $\alpha = \{\alpha_1, \dots, \alpha_n\}$ be a set of elements of K that is algebraically independent over F , and let $F(\alpha)$ be the field of fractions of $F[\alpha]$.*

- (i) *Every element of the field $F(\alpha)$ that isn't in F is transcendental over F .*
- (ii) *If β is another element of K , the set $\{\alpha_1, \dots, \alpha_n, \beta\}$ is algebraically dependent if and only if β is algebraic over $F(\alpha)$.*
- (iii) *The algebraically independent set α is a transcendence basis if and only if every element of K is algebraic over $F(\alpha)$.*

proof. (i) We can write an element z of $F(\alpha)$ as a fraction $p/q = p(\alpha)/q(\alpha)$, where $p(x)$ and $q(x)$ are relatively prime polynomials. Suppose that z satisfies a nontrivial polynomial relation $c_0z^n + c_1z^{n-1} + \dots + c_n = 0$ with c_i in F . We may assume that $c_0 = 1$. Substituting $z = p/q$ and multiplying by q^n gives us the equation

$$p^n = -q(c_1p^{n-1} + \dots + c_nq^{n-1})$$

By hypothesis, α is an algebraically independent set, so this equation is equivalent with a polynomial equation in $F[x_1, \dots, x_n]$. It shows that q divides p^n , which contradicts the hypothesis that p and q are relatively prime. So z satisfies no polynomial relation, and therefore it is transcendental. \square

1.5.3. Lemma. *Let K/F be a field extension. If K has a finite transcendence basis, then all algebraically independent subsets of K are finite, and all transcendence bases have the same order.* trdeg

proof. Let $\alpha = \{\alpha_1, \dots, \alpha_r\}$ and $\beta = \{\beta_1, \dots, \beta_s\}$. Assume that K is algebraic over $F(\alpha)$ and that the set β is algebraically independent. We show that $s \leq r$. The fact that all transcendence bases have the same order will follow: If both α and β are transcendence bases, then $s \leq r$, and since we can interchange α and β , $r \leq s$.

The proof that $s \leq r$ proceeds by reducing to the trivial case that β is a subset of α . Suppose that some element of β , say β_s , isn't in the set α . The set $\beta' = \{\beta_1, \dots, \beta_{s-1}\}$ is algebraically independent, but it isn't a transcendence basis. So K isn't algebraic over $F(\beta')$. Since K is algebraic over $F(\alpha)$, there is at least one element of α , say α_r , that isn't algebraic over $F(\beta')$. Then $\gamma = \beta' \cup \{\alpha_s\}$ will be an algebraically independent set of order s , and it contains more elements of the set α than β does. Induction shows that $s \leq r$. \square

1.5.4. Corollary. *Let $L \supset K \supset F$ be fields. and If the degree $[L : K]$ of L over K is finite, then K and L have the same transcendence degree over F .* sametrdeg

1.6 The Dual Curve

###reread this page### dualcurve

(1.6.1) the dual plane dualplane- sect

Let \mathbb{P} denote the projective plane with coordinates x_0, x_1, x_2 , and let L be the line in \mathbb{P} with the equation

$$(1.6.2) \quad s_0x_0 + s_1x_1 + s_2x_2 = 0$$
lineequa-
tion

The solutions of this equation determine the coefficients s_i only up to a common nonzero scalar factor, so L determines a point (s_0, s_1, s_2) in another projective plane \mathbb{P}^* called the *dual plane*. We denote that point by L^* . Moreover, a point $p = (x_0, x_1, x_2)$ in \mathbb{P} determines a line in the dual plane, the line with the equation (1.6.2), when s_i are regarded as the variables and x_i as the scalar coefficients. We denote that line by p^* . The equation exhibits a duality between \mathbb{P} and \mathbb{P}^* . A point p of \mathbb{P} lies on the line L if and only if the equation is satisfied, and this means that, in \mathbb{P}^* , the point L^* lies on the line p^* .

(1.6.3) the dual curve dual- curvetwo

Let C be a plane projective curve of degree at least two, and let U be the set of its smooth points. Corollary 1.4.7 tells us that U is the complement of a finite subset of C . We define a map

$$U \xrightarrow{t} \mathbb{P}^*$$

as follows: Let p be a point of U and let L be the tangent line to C at p . We define $t(p) = L^*$, where L^* is the point of \mathbb{P}^* that corresponds to the line L .

We use vector notation: $x = (x_0, x_1, x_2)$, $s = (s_0, s_1, s_2)$ and, we denote (f_0, f_1, f_2) by ∇f , with $f_i = \frac{\partial f}{\partial x_i}$ as before. The tangent line L at a smooth point $p = (x_0, x_1, x_2)$ of C has the equation $f_0x_0 + f_1x_1 + f_2x_2 = 0$ (1.4.12). Therefore L^* is the point

$$(1.6.4) \quad (s_0, s_1, s_2) = (f_0(x), f_1(x), f_2(x)) = \nabla f(x)$$
ellstare-
quation

We assume that C has degree at least two because, if C were a line, tU would be a point. Since the partial derivatives have no common factor, the tangent lines aren't constant when the degree is two or more.

phize-
rogzero

1.6.5. Lemma. Let $\varphi(s_0, s_1, s_2)$ be a homogeneous polynomial, and let $g(x_0, x_1, x_2) = \varphi(f_0(x), f_1(x), f_2(x)) = \nabla f(x)$. Then $\varphi(s)$ is identically zero on tU if and only if $g(x)$ is identically zero on U . This is true if and only if f divides g .

proof. The point s is on tU if and only if it has the form $\nabla f(x)$ with x in U , and if so, then $\varphi(s) = g(x)$. The last assertion follows from Corollary 1.3.15. \square

dual-
curvethm

1.6.6. Theorem. Let C be the plane curve defined by an irreducible homogeneous polynomial f whose degree d is at least two. With notation as above, the image tU is contained in a curve C^* in the dual plane \mathbb{P}^* .

The curve C^* referred to in the theorem is the *dual curve*.

proof. If an irreducible homogeneous polynomial $\varphi(s)$ vanishes on tU , it will be unique up to scalar factor (Corollary 1.3.15).

We show first that there is a nonzero polynomial $\varphi(s)$, not necessarily irreducible or homogeneous, that vanishes on tU . The field $\mathbb{C}(x_0, x_1, x_2)$ has transcendence degree three over \mathbb{C} . Therefore the four polynomials f_0, f_1, f_2 , and f are algebraically dependent. There is a nonzero polynomial $\psi(s_0, s_1, s_2, t)$ such that $\psi(f_0(x), f_1(x), f_2(x), f(x)) = \psi(\nabla f(x), f(x))$ is the zero polynomial. We can cancel factors of t , so we may assume that ψ isn't divisible by t . Let $\varphi(s) = \psi(s_0, s_1, s_2, 0)$. This isn't the zero polynomial when t doesn't divide ψ .

Let $x = (x_1, x_2, x_3)$ be a vector that represents a point of U . Then $f(x) = 0$, and therefore

$$\psi(\nabla f(x), f(x)) = \psi(\nabla f(x), 0) = \varphi(\nabla f(x))$$

Since $\psi(\nabla f(x), f(x))$ is identically zero, $\varphi(\nabla f(x)) = 0$ for all x in U .

Next, since f has degree d , the derivatives f_i are homogeneous of degree $d - 1$. Therefore $\nabla f(\lambda x) = \lambda^{d-1} \nabla f(x)$ for all λ , and because the vectors x and λx represent the same point of U , $\varphi(\nabla f(\lambda x)) = \varphi(\lambda^{d-1} \nabla f(x)) = 0$ for all λ , when x is in U . Writing $\nabla f(x) = s$, $\varphi(\lambda^{d-1} s) = 0$ for all λ when x is in U . Since λ^{d-1} can be any complex number, Lemma 1.3.2 tells us that the homogeneous parts of $\varphi(s)$ vanish at s , when $s = \nabla f(x)$ and x is in U . So the homogeneous parts of $\varphi(s)$ vanish on tU . This shows that there is a homogeneous polynomial $\varphi(s)$ that vanishes on tU . We choose such a polynomial $\varphi(s)$. Let its degree be r .

If f has degree d , the polynomial $g(x) = \varphi(\nabla f(x))$ will be homogeneous, of degree $r(d-1)$. It will vanish on U , and therefore on C (1.3.20). So f will divide g . Finally, if $\varphi(s)$ factors, then $g(x)$ factors accordingly, and because f is irreducible, it will divide one of the factors of g . The corresponding factor of φ will vanish on tU (1.6.5). So we may replace the homogeneous polynomial φ by one of its irreducible factors. \square

In principle, the proof of Theorem 1.6.6 gives a method for finding a polynomial that vanishes on the dual curve. One looks for a polynomial relation among f_x, f_y, f_z, f , and then sets $f = 0$. But it is usually painful to determine the defining polynomial of C^* explicitly. Most often, the degrees of C and C^* will be different, and several points of the dual curve C^* may correspond to a singular point of C , and vice versa.

We give two examples in which the computation is easy.

exampled-
ualone

1.6.7. Examples.

(i) *(the dual of a conic)* Let $f = x_0x_1 + x_0x_2 + x_1x_2$ and let C be the conic $f = 0$. Let $(s_0, s_1, s_2) = (f_0, f_1, f_2) = (x_1+x_2, x_0+x_2, x_0+x_1)$. Then

exampled-
ualtwo

$$(1.6.8) \quad s_0^2 + s_1^2 + s_2^2 - 2(x_0^2 + x_1^2 + x_2^2) = 2f \quad \text{and} \quad s_0s_1 + s_1s_2 + s_0s_2 - (x_0^2 + x_1^2 + x_2^2) = 3f$$

We eliminate $(x_0^2 + x_1^2 + x_2^2)$ from the two equations.

equationd-
ualthree

$$(1.6.9) \quad (s_0^2 + s_1^2 + s_2^2) - 2(s_0s_1 + s_1s_2 + s_0s_2) = -4f$$

Setting $f = 0$ gives us the equation of the dual curve. It is another conic.

(ii) *(the dual of a cuspidal cubic)* It is too much work to compute the dual of a smooth cubic here. The dual is a curve of degree 6. We compute the dual of a cubic with a cusp instead. The curve C defined by the irreducible polynomial $f = y^2z + x^3$ has a cusp at $(0, 0, 1)$. The Hessian matrix of f is

$$H = \begin{pmatrix} 6x & 0 & 0 \\ 0 & 2z & 2y \\ 0 & 2y & 0 \end{pmatrix}$$

and the Hessian determinant $\det H$ is $h = -24xy^2$. The common zeros of f and h are the cusp point $(0, 0, 1)$ and a single flex point $(0, 1, 0)$.

We scale the partial derivatives of f to simplify notation. Let $u = f_x/3 = x^2$, $v = f_y/2 = yz$, and $w = f_z = y^2$. Then

$$v^2w - u^3 = y^4z^2 - x^6 = (y^2z + x^3)(y^2z - x^3) = f(y^2z - x^3)$$

The zero locus of the irreducible polynomial $v^2w - u^3$ is the dual curve. It is another cuspidal cubic. \square

(1.6.10) a local equation for the dual curve

equation of star

We label the coordinates in \mathbb{P} and \mathbb{P}^* as x, y, z and u, v, w , respectively, and we work in a neighborhood of a smooth point p_0 of the curve C defined by a homogeneous polynomial $f(x, y, z)$, choosing coordinates so that $p_0 = (0, 0, 1)$, and that the tangent line at p_0 is the line $L_0 : \{y = 0\}$. The image of p_0 in the dual curve C^* is $L_0^* : (u, v, w) = (0, 1, 0)$.

Let $\tilde{f}(x, y) = f(x, y, 1)$. In the affine x, y -plane, the point p_0 becomes the origin $p_0 = (0, 0)$. So $\tilde{f}(p_0) = 0$, and since the tangent line is L_0 , $\frac{\partial \tilde{f}}{\partial x}(p_0) = 0$, while $\frac{\partial \tilde{f}}{\partial y}(p_0) \neq 0$. We solve the equation $\tilde{f} = 0$ for y as an analytic function $y(x)$, with $y(0) = 0$. Let $y'(x)$ denote the derivative $\frac{dy}{dx}$. Differentiating the equation $f(x, y(x)) = 0$ shows that $y'(0) = 0$.

Let $\tilde{p}_1 = (x_1, y_1)$ be a point of C_0 near to \tilde{p}_0 , so that $y_1 = y(x_1)$, and let $y'_1 = y'(x_1)$. The tangent line L_1 at \tilde{p}_1 has the equation

$$(1.6.11) \quad y - y_1 = y'_1(x - x_1)$$

local tangent

Putting z back, the homogeneous equation of the tangent line L_1 at the point $p_1 = (x_1, y_1, 1)$ is

$$-y'_1x + y + (y'_1x_1 - y_1)z = 0$$

The point L_1^* of the dual plane that corresponds to L_1 is $(-y'_1, 1, y'_1x_1 - y_1)$.

Let's drop the subscript 1. As x varies, and writing $y = y(x)$ and $y' = y'(x)$, L^* is the point

$$(1.6.12) \quad (u, v, w) = (-y', 1, y'x - y),$$

proj local tangent

(1.6.13) the bidual

bidual one

The *bidual* C^{**} of a curve C is the dual of the curve C^* . It is a curve in the space \mathbb{P}^{**} , which is \mathbb{P} .

1.6.14. Theorem. *A plane curve of degree greater than one is equal to its bidual: $C^{**} = C$.*

bidual C

For the proof, we use the following notation:

- U is the set of smooth points of a curve C , as above, and U^* is the set of smooth points of the dual curve C^* .

- $U^* \xrightarrow{t^*} \mathbb{P}^{**} = \mathbb{P}$ is the map analogous to the map $U \xrightarrow{t} \mathbb{P}^*$.

- V is the set of points p of C such that p is a smooth point of C and also $t(p)$ is a smooth point of C^* .

- V^* is the image $t(V)$ of V .

Thus $V \subset U \subset C$ and $V^* \subset U^* \subset C^*$.

1.6.15. Lemma.

vopen

(i) V is the complement of a finite set of points of C .

(ii) Let p_1 be a point near to a smooth point p of a curve C , let L_1 and L be the tangent line to C at p_1 and p , respectively, and let q be intersection point $L_1 \cap L$. Then $\lim_{p_1 \rightarrow p_0} q = p$.

(iii) If p is a point of V with tangent line L , the tangent line to C^* at L^* is p^* , and $t^*(L^*) = p$.

proof. (i) If S and S^* denote the finite sets of singular points of C , and C^* , respectively, V is obtained from U by deleting points of S and points in the inverse image of S^* . The fibre of t over a point L^* of C^* is the set of smooth points of C whose tangent line is L . Since L meets C in finitely many points, the fibre is finite. So the inverse image of the finite set S^* is a finite set.

(ii) We work analytically in a neighborhood of p , choosing coordinates so that $p = (0, 0, 1)$ and that L is the line $\{y = 0\}$. Let $(x_q, y_q, 1)$ be the coordinates of the intersection point q of L and L_1 . Since q is a point of L , $y_q = 0$. The coordinate x_q can be obtained by substituting $x = x_q$ and $y = 0$ into the equation (1.6.11) of L_1 : $x_q = x_1 - y_1/y'_1$.

Now, when a function has an n th order zero at the point $x = 0$, i.e., when it has the form $y = x^n h(x)$, where $n > 0$ and $h(0) \neq 0$, the order of zero of its derivative at that point is $n - 1$. This is verified by differentiating $x^n h(x)$. Since the function $y(x)$ has a zero of positive order at p , $\lim_{p_1 \rightarrow p_0} y_1/y'_1 = 0$. We also have $\lim_{p_1 \rightarrow p_0} x_1 = 0$. Therefore $\lim_{p_1 \rightarrow p_0} x_q = 0$, and $\lim_{p_1 \rightarrow p_0} q = \lim_{p_1 \rightarrow p_0} (x_q, y_q, 1) = (0, 0, 1) = p$.

curveand-
dual

1.6.16.

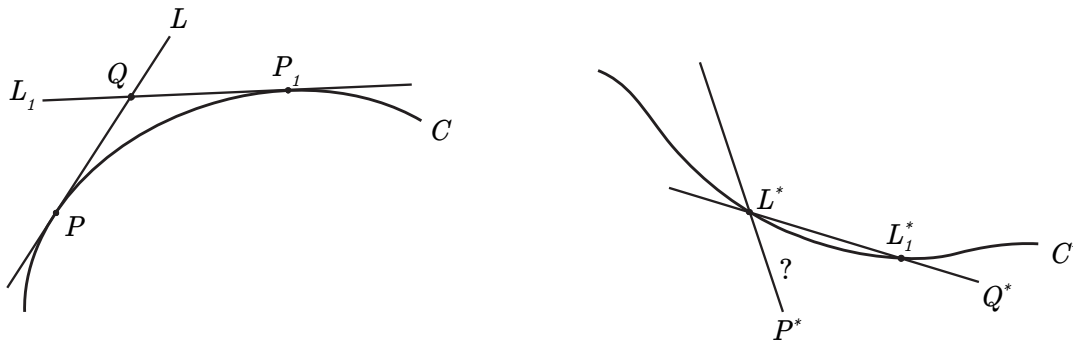

A Curve and its Dual

(iii) Let p_1 be a point of C near to p , and let L_1 be the tangent line to C at p_1 . The image of p_1 is $L_1^* = (f_0(p_1), f_1(p_1), f_2(p_1))$. Because the partial derivatives f_i are continuous,

$$\lim_{p_1 \rightarrow p_0} L_1^* = (f_0(p), f_1(p), f_2(p)) = L^*$$

With $q = L \cap L_1$ as above, q^* is the line through the points L^* and L_1^* . As p_1 approaches p , L_1^* approaches L^* , and therefore q^* approaches the tangent line to C^* at L^* . On the other hand, it follows from (ii) that q^* approaches p^* . Therefore the tangent line to C^* at L^* is p^* . By definition, $t^*(L^*)$ is point of C that corresponds to the tangent line p^* at L^* . So $t^*(L^*) = p^{**} = p$. \square

proof of theorem 1.6.14. Let p be a point of V , and let L be the tangent line at p . The map t^* is defined at L^* , and $t^*(L^*) = p$. Thus, since $L^* = t(p)$, $t^*t(p) = p$. It follows that the restriction of t to V is injective, and that it defines a bijective map from V to its image tV , whose inverse function is t^* . So V is contained in the bidual C^{**} . Since V is dense in C and since C^{**} is a closed set, C is contained in C^{**} . Since C and C^{**} are curves, $C = C^{**}$. \square

cstarisim-
age

1.6.17. Corollary. (i) Let U be the set of smooth points of a plane curve C , and let t denote the map from U to the dual curve C^* . The image tU of U is the complement of a finite subset of C^* .

(ii) If C is a smooth curve, the map $C \xrightarrow{t} C^*$, is defined at all points of C , and it is a surjective map..

(iii) Suppose that C is smooth, and that the tangent line L_0 at a point p_0 of C isn't tangent to C at another point (i.e., if L_0 isn't a bitangent). Then the path defined by the local equation (1.6.12) traces out the dual curve C^* near to $L_0^* = (0, 1, 0)$.

proof. (i) With U, U^* , and V as above, $V = t^*tV \subset t^*U^* \subset C^{**} = C$. Since V is the complement of a finite subset of C , t^*U^* is a finite subset of C too. The assertion to be proved follows when we switch C and C^* .

(ii) The map t is continuous, so its image tC is a compact subset of C^* , and by (i), its complement S is a finite set. Therefore S is both open and closed. It consists of isolated points of C^* . Since a plane curve has no isolated point (1.3.18), S is empty.

(iii) Because C is smooth, the continuous map $C \xrightarrow{t} C^*$ is defined at all points, and when L_0 isn't a bitangent, the only point that maps to L_0^* is p_0 . Then t will map a small disc D around p_0 bijectively to its image D^* . That map is the one given by the formula (1.6.12). The complement W^* of D^* in C^* is a compact space that doesn't contain L_0^* . So a small neighborhood Z of L_0^* in \mathbb{P}^* won't contain any point of W^* . Then $Z \cap C^*$ will be D^* . \square

1.7 Resultants and Discriminants

Let F and G be monic polynomials in x :

$$(1.7.1) \quad F(x) = x^m + a_1x^{m-1} + \cdots + a_m \quad \text{and} \quad G(x) = x^n + b_1x^{n-1} + \cdots + b_n$$

with variable coefficients a_i, b_j . The resultant $\text{Res}(F, G)$ of F and G is a certain polynomial in the coefficients. Its important property is that, when the coefficients of F and G are in a field, the resultant is zero if and only if F and G have a common factor.

For example, the resultant of the polynomials $F(x) = x + a$ and $G(x) = x^2 + b_1x + b_2$ is $a^2 + b_2 - ab_1$.

Suppose that the coefficients a_i and b_j in (1.7.1) are polynomials in t , so that F and G become polynomials in two variables. Let C and D be (possibly reducible) curves $F = 0$ and $G = 0$ in the affine plane $\mathbb{A}_{t,x}^2$, and let S be the set of intersections $C \cap D$. The resultant $\text{Res}(F, G)$, computed regarding x as the variable, will be a polynomial in t whose roots are the t -coordinates of the elements of S .

figure

The analogous statement is true when there are more variables. If F and G are relatively prime polynomials in x, y, z , the loci $C : \{F = 0\}$ and $D : \{G = 0\}$ in \mathbb{A}^3 will be surfaces, and $S = C \cap D$ will be a curve. The resultant $\text{Res}_z(F, G)$, computed regarding z as the variable, is a polynomial in x, y . Its zero locus in the x, y -plane is the projection of S to that plane.

The formula for the resultant is nicest when one allows leading coefficients different from 1. We work with homogeneous polynomials in two variables to prevent the degrees from dropping when a leading coefficient happens to be zero.

Let f and g be homogeneous polynomials in x and y , of degrees m and n , respectively, with complex coefficients, and let $r = m+n-1$:

$$(1.7.2) \quad f(x, y) = a_0x^m + a_1x^{m-1}y + \cdots + a_my^m, \quad g(x, y) = b_0x^n + b_1x^{n-1}y + \cdots + b_ny^n$$

Suppose that they have a common zero $(x, y) = (u, v)$ in \mathbb{P}_{xy}^1 . Then $vx-uy$ divides both g and f (see (1.3.6)). The polynomial $h = fg/(vx-uy)$ has degree $m+n-1 = r$, and it will be divisible by f and by g , say $h = pf = qg$, where p and q are homogeneous polynomials of degrees $n-1$ and $m-1$, respectively. Then h will be a linear combination pf of the polynomials $x^i y^j f$, with $i+j = n-1$, and it will also be a linear combination qg of the polynomials $x^k y^\ell g$, with $k+\ell = m-1$. The equation $pf = qg$ tells us that the $r+1$ polynomials of degree r ,

$$(1.7.3) \quad x^{n-1}f, x^{n-2}yf, \dots, y^{n-1}f ; x^{m-1}g, x^{m-2}yg, \dots, y^{m-1}g$$

will be (linearly) dependent. For example, suppose that f has degree 3 and g has degree 2. If f and g have a common zero, the polynomials

$$\begin{aligned} xf &= a_0x^4 + a_1x^3y + a_2x^2y^2 + a_3xy^3 \\ yf &= a_0x^3y + a_1x^2y^2 + a_2xy^3 + a_3y^4 \\ x^2g &= b_0x^4 + b_1x^3y + b_2x^2y^2 \end{aligned}$$

resultant

polys

hompolys

mplus-
polys

$$\begin{aligned} xyg &= b_0x^3y + b_1x^2y^2 + b_2xy^3 \\ y^2g &= bx^2y^2 + b_1xy^3 + b_2y^4 \end{aligned}$$

will be dependent. Conversely, if the polynomials (1.7.3) are dependent, there will be an equation of the form $pf = qg$, with p of degree $n-1$ and q of degree $m-1$. Then at least one zero of g must also be a zero of f .

The polynomials (1.7.3) have degree r . We form a square $(r+1) \times (r+1)$ matrix \mathcal{R} , the *resultant matrix*, whose columns are indexed by the monomials $x^r, x^{r-1}y, \dots, y^r$ of degree r , and whose rows list the coefficients of the polynomials (1.7.3). The matrix is illustrated below for the cases $m, n = 3, 2$ and $m, n = 1, 2$, with dots representing entries that are zero:

$$\text{resmatrix} \quad (1.7.4) \quad \mathcal{R} = \begin{pmatrix} a_0 & a_1 & a_2 & a_3 & \cdot \\ \cdot & a_0 & a_1 & a_2 & a_3 \\ b_0 & b_1 & b_2 & \cdot & \cdot \\ \cdot & b_0 & b_1 & b_2 & \cdot \\ \cdot & \cdot & b_0 & b_1 & b_2 \end{pmatrix} \quad \text{or} \quad \mathcal{R} = \begin{pmatrix} a_0 & a_1 & \cdot \\ \cdot & a_0 & a_1 \\ b_0 & b_1 & b_2 \end{pmatrix}$$

The *resultant* of f and g is defined to be the determinant of \mathcal{R} .

$$\text{requals-det} \quad (1.7.5) \quad \text{Res}(f, g) = \det \mathcal{R}$$

In this definition, the coefficients of f and g can be in any ring.

The resultant $\text{Res}(F, G)$ of the monic, one-variable polynomials $F(x) = x^m + a_1x^{m-1} + \dots + a_m$ and $G(x) = x^n + b_1x^{n-1} + \dots + b_n$ is the determinant of the matrix \mathcal{R} , with $a_0 = b_0 = 1$.

homogre-sult **1.7.6. Corollary.** *Let f and g be homogeneous polynomials in two variables or monic polynomials in one variable, of degrees m and n , respectively, and with coefficients in a field. The resultant $\text{Res}(f, g)$ is zero if and only if f and g have a common factor. If so, there will be polynomials p and q of degrees $n-1$ and $m-1$ respectively, such that $pf = qg$. If the coefficients are complex numbers, the resultant is zero if and only if f and g have a common root. \square*

When the leading coefficients a_0 and b_0 of f and g are both zero, the point $(1, 0)$ of \mathbb{P}_{xy}^1 will be a zero of f and of g . One could say that f and g have a common zero at infinity in this case.

weights (1.7.7) weighted degree

When defining the degree of a polynomial, one may assign an integer called a *weight* to each variable. If one assigns weight w_i to the variable x_i , the monomial $x_1^{e_1} \dots x_n^{e_n}$ gets the *weighted degree*

$$e_1w_1 + \dots + e_nw_n$$

For instance, it is natural to assign weight k to the coefficient a_k of the polynomial $f(x) = x^n - a_1x^{n-1} + a_2x^{n-2} - \dots \pm a_n$ because, if f factors into linear factors, $f(x) = (x - \alpha_1) \dots (x - \alpha_n)$, then a_k will be the k th elementary symmetric function in $\alpha_1, \dots, \alpha_n$. When written as a polynomial in α , the degree of a_k will be k .

We leave the proof of the next lemma as an exercise.

degresult **1.7.8. Lemma.** *Let $f(x, y)$ and $g(x, y)$ be homogeneous polynomials of degrees m and n respectively, with variable coefficients a_i and b_i , as in (1.7.2). When one assigns weight i to a_i and to b_i , the resultant $\text{Res}(f, g)$ becomes a weighted homogeneous polynomial of degree mn in the variables $\{a_i, b_j\}$. \square*

resroots **1.7.9. Proposition.** *Let F and G be products of monic linear polynomials, say $F = \prod_i (x - \alpha_i)$ and $G = \prod_j (x - \beta_j)$. Then*

$$\text{Res}(F, G) = \prod_{i,j} (\alpha_i - \beta_j) = \prod_i G(\alpha_i)$$

Note that, since the resultant vanishes when $\alpha_i = \beta_j$, it is divisible by $\alpha_i - \beta_j$ for all i and j . So its weighted degree mn , though rather large, is as small as it could be.

proof. The equality of the second and third terms is obtained by substituting α_i for x into the formula $G = \prod (x - \beta_j)$. We prove that the first and second terms are equal.

Let the elements α_i and β_j be variables, let R denote the resultant $\text{Res}(F, G)$ and let Π denote the product $\prod_{i,j} (\alpha_i - \beta_j)$. When we write the coefficients of F and G as symmetric functions in the roots α_i and β_j , R will be homogeneous. Its (unweighted) degree in $\{\alpha_i, \beta_j\}$ will be mn , the same as the degree of Π . To show that $R = \Pi$, we choose i, j and divide R by the polynomial $\alpha_i - \beta_j$, considered as a monic polynomial in α_i :

$$R = (\alpha_i - \beta_j)q + r,$$

where r has degree zero in α_i . The resultant R vanishes when we substitute $\alpha_i = \beta_j$. Looking at this equation, we see that the remainder r also vanishes when $\alpha_i = \beta_j$. On the other hand, the remainder is independent of α_i . It doesn't change when we set $\alpha_i = \beta_j$. Therefore the remainder is zero, and $\alpha_i - \beta_j$ divides R . This is true for all i and all j , so Π divides R , and since these two polynomials have the same degree, $R = c\Pi$ for some scalar c . To show that $c = 1$, one computes R and Π for some particular polynomials. We suggest doing the computation with $F = x^m$ and $G = x^n - 1$. \square

1.7.10. Corollary. *Let F, G , and H be monic polynomials and let c be a scalar. Then*

(i) $\text{Res}(F, GH) = \text{Res}(F, G) \text{Res}(F, H)$, and

(ii) $\text{Res}(F(x-c), G(x-c)) = \text{Res}(F(x), G(x))$. \square

restrivialities

(1.7.11) the discriminant

discrimsect

The *discriminant* $\text{Discr}(F)$ of a polynomial $F = a_0x^m + a_1x^{m-1} + \dots + a_m$ is the resultant of F and its derivative F' :

$$(1.7.12) \quad \text{Discr}(F) = \text{Res}(F, F')$$

discrdef

It is computed using the formula for the resultant of a polynomial of degree m , and it will be a weighted polynomial of degree $m(m-1)$. The definition makes sense when the leading coefficient a_0 is zero, but the discriminant will be zero in that case.

When F is a polynomial of degree n with complex coefficients, the discriminant is zero if and only if F has a multiple root, which happens when F and F' have a common factor.

Note. The formula for the discriminant is often normalized by a factor $\pm a_0^k$. We won't make this normalization, so our formula is slightly different from the usual one.

The discriminant of the quadratic polynomial $F(x) = ax^2 + bx + c$ is

$$(1.7.13) \quad \det \begin{pmatrix} a & b & c \\ 2a & b & \cdot \\ \cdot & 2a & b \end{pmatrix} = -a(b^2 - 4ac)$$

discrquadr

and the discriminant of a monic cubic $x^3 + px + q$ whose quadratic coefficient is zero is

$$(1.7.14) \quad \det \begin{pmatrix} 1 & \cdot & p & q & \cdot \\ \cdot & 1 & \cdot & p & q \\ 3 & \cdot & p & \cdot & \cdot \\ \cdot & 3 & \cdot & p & \cdot \\ \cdot & \cdot & 3 & \cdot & p \end{pmatrix} = 4p^3 + 27q^2$$

discrcubic

These are the negatives of the usual formulas. The signs are artifacts of our definition.

Though it conflicts with our definition, we'll follow tradition and continue writing the discriminant of the polynomial $ax^2 + bx + c$ as $b^2 - 4ac$.

Suppose that the coefficients a_i of F are polynomials in t , so that F becomes a polynomial in two variables. Let C be the locus $F = 0$ in the affine plane $\mathbb{A}_{t,x}^2$. The discriminant $\text{Discr}_x(F)$, computed regarding x as the variable, will be a polynomial in t . At a root t_0 of the discriminant, the line $L_0 : \{t = t_0\}$ is tangent to C , or passes through a singular point of C .

discrnotzero

1.7.15. Proposition. *Let K be a field of characteristic zero. The discriminant of an irreducible polynomial F with coefficients in K isn't zero. Therefore F has no multiple root.*

proof. When F is irreducible, it cannot have a factor in common with the derivative F' , which has lower degree. \square

This proposition is false when the characteristic of K isn't zero. In characteristic p , the derivative F' might be the zero polynomial.

discrformulas

1.7.16. Proposition. *Let $F = \prod (x - \alpha_i)$ be a product of monic linear factors. Then*

$$\text{Discr}(F) = \prod_i F'(\alpha_i) = \prod_{i \neq j} (\alpha_i - \alpha_j) = \pm \prod_{i < j} (\alpha_i - \alpha_j)^2$$

proof. The fact that $\text{Discr}(F) = \prod F'(\alpha_i)$ follows from (1.7.9). To show that $F'(\alpha_i) = \prod_{j, j \neq i} (\alpha_i - \alpha_j)$, we note that

$$\prod_{j, j \neq i} (\alpha_i - \alpha_j) = \prod_i (\alpha_i - \alpha_1) \cdots (\widehat{\alpha_i - \alpha_i}) \cdots (\alpha_i - \alpha_n)$$

where the hat $\widehat{}$ indicates that that term is deleted. By the product rule for differentiation,

$$F'(x) = \sum_k (x - \alpha_1) \cdots (\widehat{x - \alpha_k}) \cdots (x - \alpha_n)$$

When we substitute $x = \alpha_i$, all terms in this sum, except the one with $i = k$, become zero. \square

translate-discr
discrprop

1.7.17. Corollary. $\text{Discr}(F(x)) = \text{Discr}(F(x - c))$. \square

1.7.18. Proposition. *Let $F(x)$ and $G(x)$ be monic polynomials. Then*

$$\text{Discr}(FG) = \pm \text{Discr}(F) \text{Discr}(G) \text{Res}(F, G)^2$$

proof. This proposition follows from Propositions 1.7.9 and 1.7.16 for polynomials with complex coefficients. It is true for polynomials with coefficients in any ring because it is an identity. For the same reason, Corollary 1.7.10 remains true with coefficients in any ring. \square

When f and g are polynomials in several variables, one of which is z , $\text{Res}_z(f, g)$ and $\text{Discr}_z(f)$ will denote the resultant and the discriminant, computed regarding f, g as polynomials in z . They will be polynomials in the other variables.

firroverK

1.7.19. Lemma. *Let f be an irreducible polynomial in $\mathbb{C}[x, y, z]$ of positive degree in z , but not divisible by z . The discriminant $\text{Discr}_z(f)$ of f with respect to the variable z is a nonzero polynomial in x, y .*

proof. This follows from Lemma 1.3.13 (ii) and Proposition 1.7.15. \square

1.8 Nodes and Cusps

nodes
singmult

(1.8.1) the multiplicity of a singular point

Let C be the projective curve defined by an irreducible homogeneous polynomial $f(x, y, z)$ of degree d , and let p be a point of C . We choose coordinates so that $p = (0, 0, 1)$, and we set $z = 1$. This gives us an

affine curve C_0 in $\mathbb{A}_{x,y}^2$, the zero set of the polynomial $\tilde{f}(x, y) = f(x, y, 1)$, and p becomes the origin $(0, 0)$. We write

$$(1.8.2) \quad \tilde{f}(x, y) = f_0 + f_1 + f_2 + \cdots + f_d \quad \text{seriesf}$$

where f_i is the homogeneous part of \tilde{f} of degree i , which is the coefficient of z^{d-i} in $f(x, y, z)$. If the origin p is a point of C_0 , the constant term f_0 will be zero, and the linear term f_1 will define the tangent direction to C_0 at p . If f_0 and f_1 are both zero, p will be a singular point of C .

It seems permissible to drop the tilde and the subscript 0 in what follows, denoting $f(x, y, 1)$ by $f(x, y)$, and C_0 by C .

We use analogous notation for an analytic function $f(x, y)$ (see 1.4.18). Let f_i denote the homogeneous part of f of degree i :

$$(1.8.3) \quad f(x, y) = f_0 + f_1 + \cdots \quad \text{mult}$$

Let C denote the locus of zeros of f in a neighborhood of $p = (0, 0)$. To describe the singularity of C at p , we look at the part of f of lowest degree. The smallest integer r such that $f_r(x, y)$ isn't zero is the *multiplicity* of p . When that multiplicity is r , f will have the form $f_r + f_{r+1} + \cdots$.

Let L be a line $\{vx = uy\}$ through p , and suppose that $u \neq 0$. The intersection multiplicity (1.3.8) of C and L at p is the order of zero of the series in x obtained by substituting $y = vx/u$ into f . The multiplicity will be r unless $f_r(u, v)$ is zero. If $f_r(u, v) = 0$, it will be greater than r . A line L through p whose intersection multiplicity with C at p is greater than the multiplicity of C at p will be called a *special line*. The special lines correspond to the zeros of f_r in \mathbb{P}^1 . Because f_r has degree r , there will be at most r special lines.

1.8.4. goober14

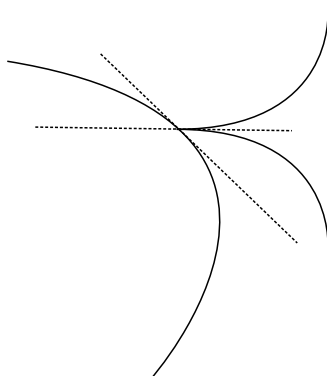

a Singular Point, with its Special Lines

A note about figures. In algebraic geometry, the dimensions are too big to allow realistic figures. Even with an affine plane curve, one is dealing with a locus in the space \mathbb{A}^2 , whose dimension in the classical topology is four. In some cases, such as in Figure 1.8.4 above, depicting the real locus can be helpful, but in most cases, even the real locus is too big, and one must make do with a schematic diagram. The figure below is an example of such a diagram. My students have told me that all of my figures look more or less like this:

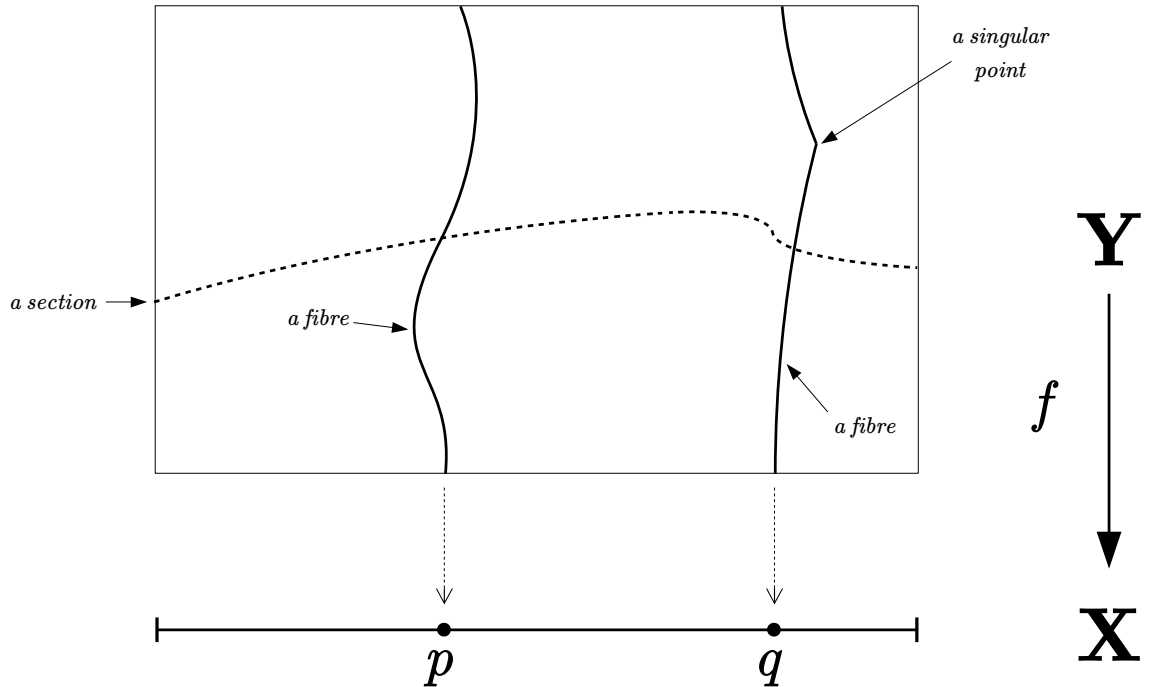

A typical Schematic Figure

dpt (1.8.6) double points

To analyze a singularity at the origin, one may blow up the plane. The *blowup* is the map $W \xrightarrow{\pi} X$ from the (x, w) -plane W to the (x, y) -plane X defined by $\pi(x, w) = (x, xw)$. It is called a “blowup” of X because the fibre over the origin in X is the w -axis $\{x = 0\}$ in W : $\pi(0, w) = (0, 0)$ for all w . The blowup map π is bijective at points at which $x \neq 0$, and points $(x, 0)$ of X with $x \neq 0$ aren't in its image. (It might seem more appropriate to call the inverse of π the blowup, but the inverse isn't a map.)

Suppose that the origin p is a *double point*, a point of multiplicity 2, and let the quadratic part of f be

$$(1.8.7) \quad f_2 = ax^2 + bxy + cy^2$$

quadrat-
ic term

We adjust coordinates so that c isn't zero, and we normalize c to 1. Writing $f(x, y) = ax^2 + bxy + y^2 + dx^3 + \dots$, we make the substitution $y = xw$ and cancel x^2 . This gives us a polynomial

$$g(x, w) = f(x, xw)/x^2 = a + bw + w^2 + dx + \dots$$

in which all of the terms represented by \dots are divisible by x . Let D be the locus $\{g = 0\}$ in W . The map π restricts to a map $D \xrightarrow{\bar{\pi}} C$. Since π is bijective at points at which $x \neq 0$, so is $\bar{\pi}$.

Suppose first that the quadratic polynomial $y^2 + by + a$ has distinct roots α, β , so that $ax^2 + bxy + y^2 = (y - \alpha x)(y - \beta x)$ and $g(x, w) = (w - \alpha)(w - \beta) + dx + \dots$. In this case, the fibre of D over the origin p in X consists of the two points $p_1 = (0, \alpha)$ and $p_2 = (0, \beta)$. The partial derivative $g_w = \frac{\partial g}{\partial w}$ isn't zero at p_1 and p_2 , so those are smooth points of D . We can solve $g(x, w) = 0$ for w as analytic functions of x , say $w = u(x)$ and $w = v(x)$ with $u(0) = \alpha$ and $v(0) = \beta$. The image of $\pi(D)$ is C , so C has two analytic branches $y = xu(x)$ and $y = xv(x)$ through the origin with distinct tangent directions α and β . The singularity of C at p is called a *node*. A node is the simplest singularity that a curve can have.

When the discriminant $b^2 - 4ac$ is zero, f_2 will be a square. We will have

$$f(x, y) = (y - \alpha x)^2 + dx^3 + \dots$$

In this case, the blowup substitution $y = xw$ gives $g(x, w) = f(x, xw)/x^2 = (w - \alpha)^2 + dx + \dots$. Here the fibre over $(x, y) = (0, 0)$ is the point $(x, w) = (0, \alpha)$, and $g_w(0, \alpha) = 0$. However, when $d \neq 0$, $g_x(0, \alpha) \neq 0$. In this case, D is smooth at $(0, 0)$, and the equation of C has the form $(y - \alpha x)^2 = dx^3 + \dots$. When $d \neq 0$, the singularity at the origin is called a *cusp*. The *standard cusp* is the locus $y^2 = x^3$. All cusps are analytically equivalent with the standard cusp.

1.8.8. Corollary. A double point p of a curve C is a node or a cusp if and only if the blowup of C is smooth at the points that lie over p . □

node-or-cusp

The simplest example of a double point that isn't a node or cusp is a *tacnode*, a point at which two smooth branches of a curve intersect with the same tangent direction.

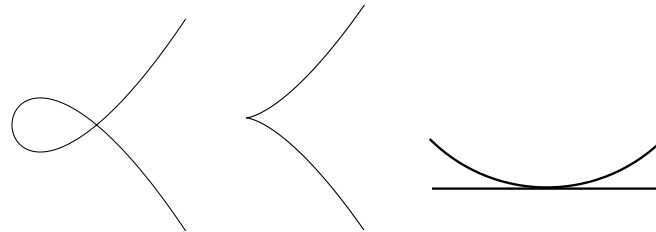

goober23

1.8.9. a Node, a Cusp, and a Tacnode (real locus)

Cusps have an interesting geometry. The intersection of the standard cusp $X : \{y^2 = x^3\}$ with a small 3-sphere $S : \{\bar{x}x + \bar{y}y = \epsilon\}$ in \mathbb{C}^2 is a *trefoil knot*, as is illustrated below.

1.8.10.

trefoil

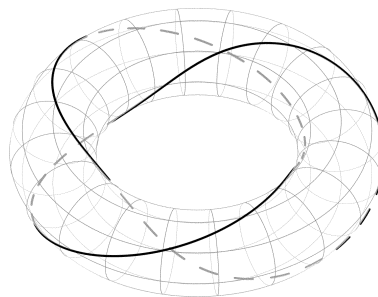

Intersection of a Cusp Curve with a three-Sphere in the Affine Plane

To obtain the figure, we have parametrized the standard cusp X by $(x(t), y(t)) = (t^3, t^2)$, and set $t = e^{i\theta}$. The locus of points of X of absolute value $r = \sqrt{2}$ is $(x(t), y(t)) = (e^{2i\theta}, e^{3i\theta})$. To visualize this locus, we

embed it into the product of an x -circle and a y -circle – a torus. We depict that torus as the usual torus T in \mathbb{R}^3 . (One has to distort the torus to do this.) The circumference of T represents the x -coordinate, and the loop through the hole represents y . As θ runs from 0 to 2π , $(x(t), y(t))$ goes around the circumference twice, and it loops through the hole three times, as is illustrated. \square

tracecusp

1.8.11. Proposition. Let $x(t) = t^2 + \dots$ and $y(t) = t^3 + \dots$ be analytic functions of t (1.4.18), whose orders of vanishing are 2 and 3, as indicated. For small t , the path $(x, y) = (x(t), y(t))$ traces out a curve with a cusp at the origin in the x, y -plane.

proof. We show that there are analytic functions $b(x) = b_2x^2 + \dots$ and $c(x) = x^3 + \dots$ that vanish to orders 2 and 3 at $x = 0$, such that $x(t)$ and $y(t)$ solve the equation $y^2 + b(x)y + c(x) = 0$. The locus of this equation has a cusp at $(x, y) = (0, 0)$.

We solve for b and c : Since $x = t^2 + \dots = t^2(1 + \dots)$, x has an analytic square root $z = t + \dots$. This follows from the Implicit Function Theorem, which also tells us that t can be written as an analytic function of z . The function z is a coordinate equivalent to t , so we may replace t by z . Then $x = z^2$, and as before, $y = z^3 + \dots$, though the series for y is changed.

Let call the *even part* of a series $\sum a_n t^n$ the sum of the terms $a_n t^n$ with n even, and the *odd part* the sum of terms with n odd. We write $y(t) = u(t) + v(t)$, where u and v are the even and the odd parts of y , respectively. A convergent series is absolutely convergent within its radius of convergence. So $u(t)$ and $v(t)$ are also absolutely convergent series.

Now $y^2 = (u^2 + v^2) + 2uv$. Here the even part of the series y^2 is $u^2 + v^2$ and the odd part is $2uv$. The series $2u$ is also even, so it can be written as a (convergent) series in $x = t^2$. Let $b(x) = -2u$. Then $by = -2u(u + v) = -2u^2 - 2uv$, and $y^2 + by = v^2 - u^2$. This even series in t can be written as $-c(x)$, so that $y^2 + by + c = 0$. The orders of vanishing of b and c are determined by the equation. \square

coverline

(1.8.12) projection to a line

We denote by π the *projection* $\mathbb{P}^2 \rightarrow \mathbb{P}^1$ that drops the last coordinate, sending a point (x, y, z) to (x, y) . This projection is defined at all points of \mathbb{P}^2 except at the *center of projection*, the point $q = (0, 0, 1)$.

The fibre of π over a point $\tilde{p} = (x_0, y_0)$ of \mathbb{P}^1 is the line through $p = (x_0, y_0, 0)$ and $q = (0, 0, 1)$, with the point q omitted – the set of points (x_0, y_0, z_0) . We may denote that line, either by L_{pq} , or by $L_{\tilde{p}}$:

projtoline

1.8.13.

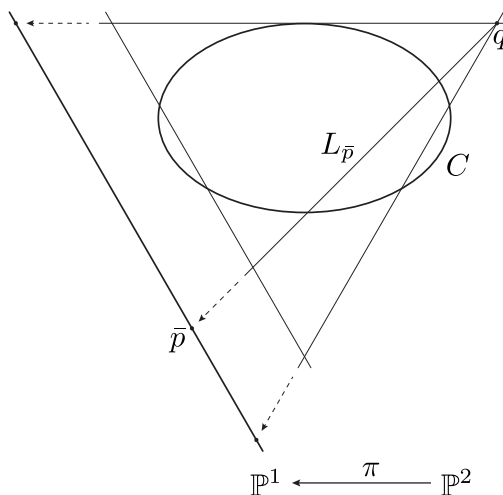

Projection from the Plane to a Line

The projection $\mathbb{P}^2 \xrightarrow{\pi} \mathbb{P}^1$ will be defined at all points of a plane curve C , provided that the center of projection q isn't a point of C . Say that C is defined by an irreducible homogeneous polynomial $f(x, y, z)$ of degree d . We write f as a polynomial in z ,

(1.8.14)
$$f = c_0z^d + c_1z^{d-1} + \dots + c_d$$

poly-
inztwo

with c_i homogeneous, of degree i in x, y . Then $c_0 = f(0, 0, 1)$ will be a constant that isn't zero when $q \notin C$. We normalize c_0 to 1, so that f becomes a monic polynomial of degree d in z .

The fibre of C over a point $\tilde{p} = (x_0, y_0)$ of \mathbb{P}^1 is the intersection of C with the line L_{pq} described above. It consists of the points (x_0, y_0, α) such that α is a root of the one-variable polynomial

$$(1.8.15) \quad \tilde{f}(z) = f(x_0, y_0, z) \quad \text{effp}$$

We call C a *branched covering* of \mathbb{P}^1 of degree d . All but finitely many fibres of C over \mathbb{P}^1 consist of d points (Lemma 1.7.19). The fibres with fewer than d points are those above the zeros of the discriminant. Those zeros are the *branch points* of the covering.

1.8.16. Proposition. *Let C be a smooth plane curve, let q be a generic point of the plane, and let p be a point of C whose tangent line L contains q . The intersection multiplicity of L and C at p is 2, and L and C will have $d - 2$ other intersections of multiplicity 1.* flexbitan

The proof is below, but first, we explain the word *generic*.

(1.8.17) generic and general position genpos

In algebraic geometry, the word *generic* is used for an object such as a point, that has no special 'bad' properties. Typically, the object will be parametrized somehow, and the adjective *generic* indicates that the parameter representing that particular object avoids a proper closed subset of the parameter space, that may be described explicitly or not. The phrase *general position* has a similar meaning. It indicates that an object is not in a 'bad' position. In Proposition 1.8.16, what is required of the generic point q is that it shall not lie on a flex tangent line or on a *bitangent line*, a line that is tangent to C at two or more points. We have seen that a smooth curve C has finitely many flex points (1.4.17), and Lemma 1.8.18 below shows that C has finitely many bitangents. So q must avoid a finite set of lines. Most points of the plane will be generic in this sense. \square

proof of Proposition 1.8.16. The intersection multiplicity of L and C at p is at least 2 because L is a tangent line at p . It will be equal to 2 unless p is a flex point. The generic point q won't lie on any of the finitely many flex tangents, so the intersection multiplicity at p is 2. Next, the intersection multiplicity at another point p' of $L \cap C$ will be 1 unless L is tangent to C at p' as well as at p , i.e., unless L is a bitangent. The generic point q won't lie on a bitangent.

1.8.18. Lemma. *A plane curve has finitely many bitangent lines.* finbitan

proof. This is an opportunity to use the map $U \xrightarrow{t} C^*$ from the set U of smooth points of C to the dual curve C^* . If L is tangent to C at distinct smooth points p and p' , then t is defined at p and p' , and $t(p) = t(p') = L^*$. Therefore L^* will be a singular point of C^* . Since C^* has finitely many singular points, C has finitely many bitangents. It seems rather clear that L^* must be a singular point, but if a proof is desired, one can argue this way: If C^* were smooth at L^* , the inverse map $C^* \xrightarrow{t^*} C^{**} = C$ would be defined at L^* . Its image would be just one point. \square

(1.8.19) the genus of a plane curve genus

We describe the topological structure of a smooth plane curve in the classical topology.

1.8.20. Theorem. *A smooth projective plane curve of degree d is a compact, orientable and connected manifold of dimension two.* curveshomeomorphic

The fact that a smooth curve is a two-dimensional manifold follows from the Implicit Function Theorem. (See the discussion (1.4.4)).

orientability: A two-dimensional manifold is orientable if one can choose one of its two sides (as in front and back of a sheet of paper) in a continuous, consistent way. A smooth curve C is orientable because its

tangent space at a point, the affine line with the equation (1.4.11), is a one-dimensional complex vector space. Multiplication by i orients the tangent space by defining the counterclockwise rotation. Then the right-hand rule tells us which side of C is “up”.

compactness: A plane projective curve is compact because it is a closed subset of the compact space \mathbb{P}^2 .

The connectedness of a plane curve is a subtle fact whose proof mixes topology and algebra. Unfortunately, I don't know a proof that fits into our discussion here. It will be proved later (see Theorem 8.3.11).

The topological *Euler characteristic* of a compact, orientable two-dimensional manifold M , which we denote by e , is the alternating sum $b^0 - b^1 + b^2$ of its Betti numbers. The Euler characteristic can be computed using a *topological triangulation*, a subdivision of M into topological triangles, called *faces*, by the formula

v ef (1.8.21)
$$e = |\text{vertices}| - |\text{edges}| + |\text{faces}|$$

For example, a sphere is homeomorphic to a tetrahedron, which has four vertices, six edges, and four faces. Its Euler characteristic is $4 - 6 + 4 = 2$. Any other topological triangulation of a sphere, such as the one given by the icosahedron, yields the same Euler characteristic.

Every compact, connected, orientable two-dimensional manifold is homeomorphic to a sphere with a finite number of “handles”. Its *genus* is the number of handles. A torus has one handle. Its genus is one. The projective line \mathbb{P}^1 , a two-dimensional sphere, has genus zero.

Figure

The Euler characteristic and the genus are related by the formula

genuseuler (1.8.22)
$$e = 2 - 2g$$

The Euler characteristic of a torus is zero, and the Euler characteristic of \mathbb{P}^1 is two.

To compute the Euler characteristic of a smooth curve C of degree d , we analyze a generic projection (see **1.8.17**), to represent C as a branched covering of the projective line: $C \xrightarrow{\pi} \mathbb{P}^1$.

figure

We choose generic coordinates x, y, z in \mathbb{P}^2 and project from the point $q = (0, 0, 1)$. When the defining equation of C is written as a monic polynomial in z : $f = z^d + c_1 z^{d-1} + \dots + c_d$ where c_i is a homogeneous polynomial of degree i in the variables x, y , the discriminant $\text{Discr}_z(f)$ with respect to z will be a homogeneous polynomial of degree $d(d-1) = d^2 - d$ in x, y .

Let \tilde{p} be the image in \mathbb{P}^1 of a point p of C . The covering $C \xrightarrow{\pi} \mathbb{P}^1$ will be branched at \tilde{p} when the tangent line at p is the line L_{pq} through p and the center of projection q . Proposition 1.8.16 tells us that if L_{pq} is a tangent line, there will be one intersection of multiplicity 2 and $d - 1$ simple intersections. The discriminant will have a simple zero at such a point \tilde{p} . This is proved in Proposition 1.9.10 below. Let's assume it for now.

Since the discriminant has degree $d^2 - d$, there will be $d^2 - d$ points \tilde{p} in \mathbb{P}^1 at which the discriminant vanishes and the fibre over such a point contains $d - 1$ points. They are the *branch points* of the covering. All other fibres consist of d points.

We triangulate the sphere \mathbb{P}^1 in such a way that the branch points are among the vertices, and we use the inverse images of the vertices, edges, and faces to triangulate C . Then C will have d faces and d edges lying over each face and each edge of \mathbb{P}^1 , respectively. There will also be d vertices of C lying over a vertex of \mathbb{P}^1 , except when the vertex is one of the $d^2 - d$ branch points. In that case the fibre will contain only $d - 1$ vertices. So the Euler characteristic of C can be obtained by multiplying the Euler characteristic of \mathbb{P}^1 by d and subtracting the number $d^2 - d$ of branch points:

eulercover (1.8.23)
$$e(C) = d e(\mathbb{P}^1) - (d^2 - d) = 2d - (d^2 - d) = 3d - d^2$$

This is the Euler characteristic of any smooth curve of degree d , so we denote it by e_d :

equatione (1.8.24)
$$e_d = 3d - d^2$$

Formula (1.8.22) shows that the genus g_d of a smooth curve of degree d is

$$(1.8.25) \quad g_d = \frac{1}{2}(d^2 - 3d + 2) = \binom{d-1}{2} \quad \text{equationg}$$

Thus smooth curves of degrees 1, 2, 3, 4, 5, 6, ... have genus 0, 0, 1, 3, 6, 10, ..., respectively. A smooth plane curve cannot have genus two.

The generic projection to \mathbb{P}^1 also computes the degree of the dual C^* of a smooth curve C of degree d . The degree of C^* is the number of its intersections with the generic line q^* in \mathbb{P}^* . The intersection points have the form L^* , where L is a tangent line that contains q . As we have seen, there are $d^2 - d$ such points.

1.8.26. Corollary. *Let C be a plane curve of degree d .* degdual

(i) *The degree d^* of the dual curve C^* is the number of tangent lines at smooth points of C that pass through a generic point q of the plane.*

(ii) *If C is smooth, $d^* = d^2 - d$.* □

When C is a singular curve, the degree of its dual curve will be less than $d^2 - d$.

If $d = 2$, C will be a smooth conic, and $d^* = d$. The dual curve is also a conic, as we have seen. But when $d > 2$, $d^* = d^2 - d$ will be greater than d . In this case the dual curve C^* must be singular. If it were smooth, the degree of its dual curve C^{**} would be $d^{*2} - d^*$. Since $d^{*2} - d^*$ would be greater than d , this would contradict the fact that $C^{**} = C$.

1.9 Hensel's Lemma

The resultant matrix (1.7.4) arises in a second context that we explain here. hensel

Suppose given a product $P = FG$ of two polynomials, say

$$(1.9.1) \quad (c_0x^{m+n} + c_1x^{m+n-1} + \cdots + c_{m+n}) = (a_0x^m + a_1x^{m-1} + \cdots + a_m)(b_0x^n + b_1x^{n-1} + \cdots + b_n) \quad \text{multiply-polys}$$

We call the relations among the coefficients implied by this polynomial equation the *product equations*. The product equations are

$$c_i = a_i b_0 + a_{i-1} b_1 + \cdots + a_0 b_i$$

for $i = 0, \dots, m+n$. For instance, when $m = 3$ and $n = 2$, the product equations are

1.9.2. prodeqns

$$\begin{aligned} c_0 &= a_0 b_0 \\ c_1 &= a_1 b_0 + a_0 b_1 \\ c_2 &= a_2 b_0 + a_1 b_1 + a_0 b_2 \\ c_3 &= a_3 b_0 + a_2 b_1 + a_1 b_2 \\ c_4 &= \quad \quad a_3 b_1 + a_2 b_2 \\ c_5 &= \quad \quad \quad a_3 b_2 \end{aligned}$$

Let J denote the Jacobian matrix of partial derivatives of c_1, \dots, c_{m+n} with respect to the variables b_1, \dots, b_n and a_1, \dots, a_m , treating a_0, b_0 and c_0 as constants. When $m, n = 3, 2$,

$$(1.9.3) \quad J = \frac{\partial(c_i)}{\partial(b_j, a_k)} = \begin{pmatrix} a_0 & \cdot & b_0 & \cdot & \cdot \\ a_1 & a_0 & b_1 & b_0 & \cdot \\ a_2 & a_1 & b_2 & b_1 & b_0 \\ a_3 & a_2 & \cdot & b_2 & b_1 \\ \cdot & a_3 & \cdot & \cdot & b_2 \end{pmatrix} \quad \text{prodjacob}$$

1.9.4. Lemma. *The Jacobian matrix J is the transpose of the resultant matrix \mathcal{R} (1.7.4).* □ jacres

1.9.5. Corollary. *Let F and G be polynomials with complex coefficients. The Jacobian matrix is singular if and only if F and G have a common root, or else $a_0 = b_0 = 0$.* □ jacobian-notzero

This corollary has an application to polynomials with analytic coefficients. Let

poly-
forhensel

$$(1.9.6) \quad P(t, x) = c_0(t)x^d + c_1(t)x^{d-1} + \cdots + c_d(t)$$

be a polynomial in x whose coefficients c_i are analytic functions of t , and let $\bar{P} = P(0, x) = \bar{c}_0x^d + \bar{c}_1x^{d-1} + \cdots + \bar{c}_d$ be the evaluation of P at $t = 0$, so that $\bar{c}_i = c_i(0)$. Suppose given a factorization $\bar{P} = \bar{F}\bar{G}$, where $\bar{G} = \bar{b}_0x^n + \bar{b}_1x^{n-1} + \cdots + \bar{b}_n$ and $\bar{F} = x^m + \bar{a}_1x^{m-1} + \cdots + \bar{a}_m$ are polynomials with complex coefficients and \bar{F} is a monic polynomial. Are there polynomials $F(t, x) = x^m + a_1x^{m-1} + \cdots + a_m$ and $G(t, x) = b_0x^n + b_1x^{n-1} + \cdots + b_n$, with F monic, whose coefficients a_i and b_i are analytic functions of t , and such that $F(0, x) = \bar{F}$, $G(0, x) = \bar{G}$, and $P = FG$?

hensellemma

1.9.7. Hensel's Lemma. *With notation as above, suppose that \bar{F} and \bar{G} have no common root. Then P factors: $P = FG$, where F and G are polynomials in x whose coefficients are analytic functions of t (1.4.18) and F is monic, as above.*

proof. We look at the product equations. Since F is supposed to be monic, we set $a_0(t) = 1$. The first product equation tells us that $b_0(t) = c_0(t)$. Corollary 1.9.5 tells us that the Jacobian matrix for the remaining product equations is nonsingular at $t = 0$, so according to the Implicit Function Theorem, the product equations have a unique solution in analytic functions $a_i(t), b_j(t)$ for small t . \square

Note that P isn't assumed to be monic. If $\bar{c}_0 = 0$, the degree of \bar{P} will be less than the degree of P . In that case, \bar{G} will have lower degree than G .

figure

henselex

1.9.8. Example. Let $P = c_0(t)x^2 + c_1(t)x + c_2(t)$. The product equations $P = FG$ with $F = x + a_1$ monic and $G = b_0x + b_1$, are

$$c_0 = b_0, \quad c_1 = a_1b_0 + b_1, \quad c_2 = a_1b_1$$

and the Jacobian matrix is

$$\frac{\partial(c_1, c_2)}{\partial(b_1, a_1)} = \begin{pmatrix} 1 & b_0 \\ a_1 & b_1 \end{pmatrix}$$

Suppose that $\bar{P} = P(0, x)$ factors: $\bar{c}_0x^2 + \bar{c}_1x + \bar{c}_2 = (x + \bar{a}_1)(\bar{b}_0x + \bar{b}_1) = \bar{F}\bar{G}$. The determinant of the Jacobian matrix at $t = 0$ is $\bar{b}_1 - \bar{a}_1\bar{b}_0$. It is nonzero if and only if the two factors are relatively prime, in which case P factors too.

On the other hand, the one-variable Jacobian criterion allows us to solve the equation $P(t, x) = 0$ for x as function of t with $x(0) = -\bar{a}_1$, provided that $\frac{\partial P}{\partial x} = 2c_0x + c_1$ isn't zero at the point $(t, x) = (0, -\bar{a}_1)$. Evaluating, $\frac{\partial P}{\partial x}(0, -\bar{a}_1) = -2\bar{c}_0\bar{a}_1 + \bar{c}_1$. Substituting $\bar{c}_0 = \bar{b}_0$ and $\bar{c}_1 = \bar{a}_1\bar{b}_0 + \bar{b}_1$, shows that $\frac{\partial P}{\partial x}(0, -\bar{a}_1) = -2\bar{c}_0\bar{a}_1 + \bar{c}_1 = \bar{b}_1 - \bar{a}_1\bar{b}_0$. Not surprisingly, $\frac{\partial P}{\partial x}(0, -\bar{a}_1)$ is equal to the determinant of the Jacobian matrix. \square

vandisc

(1.9.9) order of vanishing of the discriminant

Let $f(x, y, z)$ be a homogeneous polynomial with no multiple factors, and let C be the (possibly reducible) plane curve $\{f = 0\}$. Suppose that $q = (0, 0, 1)$ is in general position (see 1.8.17). Let L_{pq} denote the line through a point $p = (x_0, y_0, 0)$ and q , the set of points (x_0, y_0, z_0) , as before, and let $\tilde{p} = (x_0, y_0)$.

discrim-
vanishing

1.9.10. Proposition. (i) *If p is a smooth point of C with tangent line L_{pq} , the discriminant $\text{Discr}_z(f)$ has a simple zero at \tilde{p} .*

(ii) *If p is a node of C , $\text{Discr}_z(f)$ has a double zero at \tilde{p} .*

(iii) *If p is a cusp, $\text{Discr}_z(f)$ has a triple zero at \tilde{p} .*

(iv) *If p is an ordinary flex point of C (1.4.8) with tangent line L_{pq} , $\text{Discr}_z(f)$ has a double zero at \tilde{p} .*

generic-
cond

To be precise about what is required of the generic point q in this case, we ask that q not lie on any of these lines:

(1.9.11)

flex tangent lines and bitangent lines,

lines that contain more than one singular point,

special lines through singular points (see (1.8.1)),

tangent lines that contain a singular point of C .

1.9.12. Lemma. *This is a list of finitely many lines that q must avoid.* □ *finlines*

proof of Proposition 1.9.10. (i)–(iii) We'll use Hensel's Lemma. We set $x = 1$, to work in the standard affine open set \mathbb{U} with coordinates y, z . In affine coordinates, the projection π is the map $(y, z) \rightarrow y$. We may suppose that p is the origin in \mathbb{U} . Its image \tilde{p} will be the point $y = 0$ of the affine y -line, and the intersection of the line L_{pq} with \mathbb{U} will be the line $\tilde{L} : \{y = 0\}$. We'll denote the defining polynomial of the curve C , restricted to \mathbb{U} , by $f(y, z)$ instead of $f(1, y, z)$. Let $\tilde{f}(z) = f(0, z)$.

In each of the cases **(i) – (iii)**, the polynomial $\tilde{f}(z) = f(0, z)$ will have a double zero at $z = 0$, so we will have $\tilde{f}(z) = z^2 \bar{h}(z)$, with $\bar{h}(0) \neq 0$. Then z^2 and $\bar{h}(z)$ have no common root, so we may apply Hensel's Lemma to write $f(y, z) = g(y, z)h(y, z)$, where g and h are polynomials in z whose coefficients are analytic functions of y , defined for small y , g is monic, $g(0, z) = z^2$, and $h(0, z) = \bar{h}$. Then

$$(1.9.13) \quad \text{Discr}_z(f) = \pm \text{Discr}_z(g) \text{Discr}_z(h) \text{Res}_z(g, h)^2 \quad \text{discrfg}$$

(1.7.18). Since q is in general position, \bar{h} will have simple zeros. Then $\text{Discr}_z(h)$ doesn't vanish at $y = 0$, and neither does $\text{Res}_z(g, h)$. So the orders of vanishing of $\text{Discr}_z(f)$ and $\text{Discr}_z(g)$ are equal. We replace f by g .

Since g is a monic quadratic polynomial, it has the form

$$g(y, z) = z^2 + b(y)z + c(y)$$

The coefficients b and c are analytic functions of y , and $g(0, z) = z^2$. The discriminant $\text{Discr}_z(g) = b^2 - 4c$ is unchanged when we complete the square by the substitution of $z - \frac{1}{2}b$ for z , and if p is smooth or has a node or a cusp, that property isn't affected by this change of coordinates. So we may assume that g has the form $z^2 + c(y)$. The discriminant is then $D = 4c(y)$.

We write $c(y)$ as a series in y :

$$c(y) = c_0 + c_1y + c_2y^2 + c_3y^3 + \cdots$$

The constant coefficient c_0 is zero. If $c_1 \neq 0$, p is a smooth point with tangent line \tilde{L} , and D has a simple zero. If p is a node, $c_0 = c_1 = 0$ and $c_2 \neq 0$. Then D has a double zero. If p is a cusp, $c_0 = c_1 = c_2 = 0$, and $c_3 \neq 0$. Then D has a triple zero at p .

(iv) In this case, the polynomial $\tilde{f}(z) = f(0, z)$ will have a triple zero at $z = 0$. Proceeding as above, we may factor: $f = gh$ where g and h are polynomials in z with analytic coefficients in y , and $g(y, z) = z^3 + a(y)z^2 + b(y)z + c(y)$. We eliminate the quadratic coefficient a by substituting $z - \frac{1}{3a}$ for z . With $g = z^3 + bz + c$ in the new coordinates, the discriminant $\text{Discr}_z(g)$ is $4b^3 + 27c^2$ (1.7.14). We write $c(y) = c_0 + c_1y + \cdots$ and $b(y) = b_0 + b_1y + \cdots$. Since p is a point of C with tangent line $\{y = 0\}$, $c_0 = 0$ and $c_1 \neq 0$. Since the intersection multiplicity of C with the line $\{y = 0\}$ at p is three, $b_0 = 0$. The discriminant $4b^3 + 27c^2$ has a zero of order two. □

1.9.14. Corollary. *Let $C : \{g = 0\}$ and $D : \{h = 0\}$ be plane curves that intersect transversally at a point $p = (x_0, y_0, z_0)$. With coordinates in general position, $\text{Res}_z(g, h)$ has a simple zero at (x_0, y_0) .* *transres*

Two curves are said to intersect *transversally* at a point p if they are smooth at p and their tangent lines there are distinct.

proof. Proposition 1.9.10 **(ii)** applies to the product gh , whose zero locus is the union $C \cup D$. It shows that the discriminant $\text{Discr}_z(gh)$ has a double zero at p . We also have the formula (1.9.13) with $f = gh$. When coordinates are in general position, $\text{Discr}_z(g)$ and $\text{Discr}_z(h)$ will not be zero at p . Since $\text{Discr}_z(gh) = \text{Discr}_z(g) \text{Discr}_z(h) \text{Res}(g, h)^2$, $\text{Res}_z(g, h)$ has a simple zero there at p . □

1.10 Bézout's Theorem

Bézout's Theorem counts intersections of plane curves. We state it here in a form that is ambiguous because it contains a term "multiplicity" that hasn't yet been defined. *bezoutthm*

1.10.1. Bézout's Theorem. Let C and D be distinct curves of degrees m and n , respectively. When intersections are counted with an appropriate multiplicity, the number of intersections is equal to mn . Moreover, the multiplicity at a transversal intersection is 1. *bezoutone*

As before, C and D intersect transversally at p if they are smooth at p and their tangent lines there are distinct.

bezoutline

1.10.2. Corollary. *Bézout's Theorem is true when one of the curves is a line.*

See Corollary 1.3.9. The multiplicity of intersection of a curve and a line is the one that was defined there. \square

The proof in the general case requires some algebra that we would rather defer. It will be given later (Theorem 7.8.1). It is possible to determine the intersections by counting the zeros of the resultant with respect to one of the variables. To do this, one chooses coordinates x, y, z , so that neither C nor D contains the point $(0, 0, 1)$. One writes their defining polynomials f and g as polynomials in z with coefficients in $\mathbb{C}[x, y]$. The resultant R with respect to z will be a homogeneous polynomial in x, y , of degree mn . It will have mn zeros in $\mathbb{P}_{x,y}^1$, counted with multiplicity. If $\tilde{p} = (x_0, y_0)$ is a zero of R , $f(x_0, y_0, z)$ and $g(x_0, y_0, z)$, which are polynomials in z , have a common root $z = z_0$, and then $p = (x_0, y_0, z_0)$ will be a point of $C \cap D$. It is a fact that the multiplicity of the zero of the resultant R at the image \tilde{p} is the (as yet undefined) intersection multiplicity of C and D at p . Unfortunately, this won't be obvious, even when multiplicity is defined. However, one can prove the next proposition using this approach.

nocommonfactor

1.10.3. Proposition. *Let C and D be distinct plane curves of degrees m and n , respectively.*

- (i) *The curves C and D have at least one point of intersection, and the number of intersections is at most mn .*
- (ii) *If all intersections are transversal, the number of intersections is precisely mn .*

It isn't obvious that two curves in the projective plane intersect. If two curves in the affine plane have no intersection, if they are parallel lines, for instance, their closures in the projective plane meet on the line at infinity.

resnotzero

1.10.4. Lemma. *Let f and g be homogeneous polynomials in x, y, z of degrees m and n , respectively, and suppose that the point $(0, 0, 1)$ isn't a zero of f or g . If the resultant $\text{Res}_z(f, g)$ with respect to z is identically zero, then f and g have a common factor.*

proof. Let the degrees of f and g be m and n , respectively, and let F denote the field of rational functions $\mathbb{C}(x, y)$. If the resultant is zero, f and g have a common factor in $F[z]$ (Corollary 1.7.6). There will be polynomials p and q in $F[z]$, of degrees at most $n-1$ and $m-1$ in z , respectively, such that $pf = qg$ (1.7.2). We may clear denominators, so we may assume that the coefficients of p and q are in $\mathbb{C}[x, y]$. This doesn't change the degree in z . Then $pf = qg$ is an equation in $\mathbb{C}[x, y, z]$. Since p has degree at most $n-1$ in z , it isn't divisible by g , which has degree n in z . Since $\mathbb{C}[x, y, z]$ is a unique factorization domain, f and g have a common factor. \square

proof of Proposition 1.10.3. (i) Let C and D be distinct curves, defined by the irreducible polynomials f and g . Proposition 1.3.11 shows that there are finitely many intersections. We project to \mathbb{P}^1 from a point q that doesn't lie on any of the finitely many lines through pairs of points of $C \cap D$. Then a line through q passes through at most one intersection, and the zeros of the resultant $\text{Res}_z(f, g)$ that correspond to the intersection points will be distinct. Since the resultant has degree mn (1.7.8), it has at least one zero, and at most mn of them. Therefore C and D have at least one and at most mn intersections.

(ii) Every zero of the resultant will be the image of an intersection of C and D . To show that there are mn intersections if all intersections are transversal, it suffices to show that the resultant has simple zeros. This is Corollary 1.9.14. \square

smoothirred

1.10.5. Corollary. *If the curve X defined by a homogeneous polynomial $f(x, y, z)$ is smooth, then f is irreducible, and therefore X is a smooth curve.*

proof. Suppose that $f = gh$, and let p be a point of intersection of the loci $\{g = 0\}$ and $\{h = 0\}$. The previous proposition shows that such a point exists. All partial derivatives of f vanish at p , so p is a singular point of the locus $f = 0$. \square

numberof flexes

1.10.6. Proposition. (i) *Let d be an integer ≥ 3 . A smooth plane curve of degree d has at least one flex point, and the number of flex points is at most $3d(d-2)$.*

(ii) *If all flex points are ordinary, the number of flex points is equal to $3d(d-2)$.*

Thus smooth curves of degrees 2, 3, 4, 5, ... have at most 0, 9, 24, 45, ... flex points, respectively.

proof. (i) The flex points are intersections of a smooth curve C with its *Hessian divisor* $D : \{\det H = 0\}$. (We use the definition of divisor that is given in (1.3.12).) Let $C : \{f(x_0, x_1, x_2) = 0\}$ be a smooth curve of degree d . The entries of the 3×3 Hessian matrix H are the second partial derivatives $\frac{\partial^2 f}{\partial x_i \partial x_j}$. They are homogeneous polynomials of degree $d-2$, so the Hessian determinant is homogeneous, of degree $3(d-2)$. Propositions 1.4.17 and 1.10.3 tell us that there are at most $3d(d-2)$ intersections.

(ii) Recall that a flex point is ordinary if the multiplicity of intersection of the curve and its tangent line is 3. Bézout's Theorem asserts that the number of flex points is equal to $3d(d-2)$ if the intersections of C with its Hessian divisor D are transversal, and therefore have multiplicity 1. So the next lemma completes the proof.

1.10.7. Lemma. *A curve $C : \{f = 0\}$ intersects its Hessian divisor D transversally at a point p if and only if p is an ordinary flex point of C .*

transversalH

proof. We prove this by computation. I don't know a conceptual proof.

Let L be the tangent line to C at the flex point p , and let h denote the restriction of the Hessian determinant to L . The Hessian divisor D will be transversal to C at p if and only if it is transversal to L , and this will be true if and only if the order of vanishing of h at p is 1.

We adjust coordinates x, y, z so that $p = (0, 0, 1)$ and L is the line $\{y = 0\}$, and we write the polynomial f of degree d as

$$(1.10.8) \quad f(x, y, z) = \sum_{i+j+k=d} a_{ij} x^i y^j z^k,$$

fwithcoeffs

We set $y = 0$ and $z = 1$, to restrict f to L . The restriction of the polynomial f is

$$f(x, 0, 1) = \sum_{i \leq d} a_{i0} x^i$$

When p is a flex point with tangent line L , the coefficients a_{00}, a_{10} , and a_{20} will be zero, and p is an ordinary flex point if and only if the coefficient a_{30} isn't zero.

With this notation, the restriction of $\det H$ to L becomes $h = \det H(x, 0, 1)$. We must show that p is an ordinary flex point if and only if h has a simple zero at $x = 0$.

To evaluate the restriction $f_{xx}(x, 0, 1)$ of the partial derivative to L , the relevant terms in the sum (1.10.8) have $j = 0$. Since $a_{00} = a_{10} = a_{20} = 0$,

$$f_{xx}(x, 0, 1) = 6a_{30}x + 12a_{40}x^2 + \dots = 6a_{30}x + O(2)$$

Similarly,

$$f_{xz}(x, 0, 1) = 0 + O(2)$$

$$f_{zz}(x, 0, 1) = 0 + O(2)$$

For the restriction of f_{yz} , the relevant terms are those with $j = 1$:

$$f_{yz}(x, 0, 1) = (d-1)a_{01} + (d-2)a_{11}x + O(2)$$

We won't need f_{xy} or f_{yy} .

Let $v = 6a_{30}x$ and $w = (d-1)a_{01} + (d-2)a_{11}x$. The restricted Hessian matrix has the form

$$(1.10.9) \quad H(x, 0, 1) = \begin{pmatrix} v & * & 0 \\ * & * & w \\ 0 & w & 0 \end{pmatrix} + O(2)$$

where $*$ are entries that don't affect terms of degree at most one in the determinant. The determinant is

$$h = -vw^2 + O(2) = -6(d-1)^2 a_{30} a_{01}^2 x + O(2)$$

It has a zero of order 1 at $x = 0$ if and only if a_{30} and a_{01} aren't zero. Since C is smooth at p and $a_{10} = 0$, the coefficient a_{01} isn't zero. Thus the curve C and its Hessian divisor D intersect transversally, and C and L intersect with multiplicity 3, if and only if a_{30} is nonzero, which is true if and only if p is an ordinary flex point. \square

nineflexes

1.10.10. Corollary. *A smooth cubic curve contains exactly 9 flex points.*

proof. Let f be the irreducible cubic polynomial whose zero locus is a smooth cubic C . The degree of the Hessian divisor D is also 3, so Bézout predicts at most 9 intersections of D with C . To derive the corollary, we show that C intersects D transversally. According to Proposition 1.10.7, a nontransversal intersection would correspond to a point at which the curve and its tangent line intersect with multiplicity greater than 3. This is impossible when the curve is a cubic. \square

singdual

(1.10.11) singularities of the dual curve

Let C be a plane curve. As before, an *ordinary flex point* is a smooth point p such that the intersection multiplicity of the curve and its tangent line L at p is precisely 3. A bitangent, a line L that is tangent to C at distinct points p and p' , is an *ordinary bitangent* if neither p nor p' is a flex point. A tangent line L at a smooth point p of C is an *ordinary tangent* if p isn't a flex point and L isn't a bitangent.

The tangent line L at a point p will have other intersections with C . Most often, these other intersections will be transversal. However, it may happen that one of those other intersections is a singular point of C . If L is a bitangent, it may happen that it is a *tritangent*, tangent to C at a third point, or that L contains a singular point of C . Let's call such occurrences *accidents*.

ordcurve

1.10.12. Definition. A plane curve C is *ordinary* if it is smooth, all of its bitangents and flex points are ordinary, and if there are no accidents.

genisord

1.10.13. Lemma. *A generic curve C is ordinary.*

We'll verify this using counting constants. The reasoning is fairly convincing, though imprecise.

There are three ways in which a curve C might fail to be ordinary:

- (a) C may be singular.
- (b) C may have a flex point tht isn't an ordinary flex. some point.
- (c) A bitangent to C may be a flex tangent or a tritangent.

The curve will be ordinary if none of these occurs.

Let the coordinates be x, y, z , and let $f(x, y, z)$ be the defining polynomial of a curve. The homogeneous polynomials of given degree d form a vector space whose dimension is equal to the number of monomials $x^i y^j z^k$ of degree $i + j + kd$. That number isn't important, but it happens to be $\binom{d+1}{2}$. So the curves of degree d are parametrized by points of a projective space D of dimension $N = \binom{d+1}{2} - 1$.

(a) We look at the point $p_0 = (0, 0, 1)$, and we set $z = 1$. If p_0 is singular, the coefficients of $1, x, y$ in the polynomial $f(x, y, 1)$ will be zero. This is three conditions. The curves that are singular at p_0 are parametrized by a space of dimension $N - 3$. The points of \mathbb{P}^2 depend on only 2 parameters. Therefore, in the space of curves, the singular curves form a subset of dimension at most $N - 1$. (In fact, the dimension is equal to $N - 1$.) Most curves are smooth.

(b) Let's look at curves that have a four-fold tangency with the line $L : \{y = 0\}$ at p_0 . Setting $z = 1$ as before, we see that the coefficients of $1, y, y^2, y^3$ in f must be zero. This is four conditions. The lines through p_0 depend on one parameter, and the points of \mathbb{P}^2 depend on two parameters, giving us three parameters to vary. We can't get all curves this way. Most curves have no four-fold tangencies.

(c) To be tangent to the line $L : \{y = 0\}$ at the point p_0 , the coefficients of 1 and y in f must be zero. This is two conditions. Then to be tangent to L at three given points p_0, p_1, p_2 imposes 6 conditions. A set of three points of L depends on three parameters, and a line depends on two parameters, giving us 5 parameters in all. Most curves don't have a tritangent. Similar reasoning rules out bitangents that are flex tangents on a generic curve. \square

dualcusp

1.10.14. Proposition. *Let p be a point of an ordinary curve C , and let L be the tangent line at p .*

- (i) *If L is an ordinary tangent at p , then L^* is a smooth point of C^* .*
- (ii) *If L is a bitangent, then L^* is a node of C^* .*
- (iii) *If p is a flex point, then L^* is a cusp of C^* .*

proof. We refer to the map $U \xrightarrow{t} C^*$ from the set of smooth points of C to the dual curve (1.6.3). We dehomogenize by setting $z = 1$, and choose affine coordinates so that p is the origin, and the tangent line L at p is the line $\{y = 0\}$. Let $\tilde{f}(x, y) = f(x, y, 1)$. We solve $\tilde{f} = 0$ for $y = y(x)$ as an analytic function of x , as before. The tangent line L_1 to C at a nearby point $p_1 = (x, y)$ has the equation (1.6.11), and L_1^* is the point $(u, v, w) = (-y', 1, y'x - y)$ of \mathbb{P}^* (1.6.12). Since there are no accidents, this path traces out all points of C^* near to L^* .

(i) If L is an ordinary tangent line, $y(x)$ will have a zero of order 2 at $x = 0$. Then $u = -y'$ will have a simple zero. So the path $(-y', 1, y'x - y)$ is smooth at $x = 0$, and therefore C^* is smooth at the origin.

(ii) If L is an ordinary bitangent, tangent to C at two points p and p' , the reasoning given for an ordinary tangent shows that the images in C^* of small neighborhoods of p and p' in C will be smooth at L^* . Their tangent lines p^* and p'^* will be distinct, so p is a node.

(iii) Suppose that p is an ordinary flex point. Then, in the analytic function $y(x) = c_0 + c_1x + c_2x^2 + \dots$ that solves $f(x, y) = 0$ the coefficients of x^i are zero when $i < 3$, so $y(x) = c_3x^3 + \dots$. Since the flex is ordinary, we may assume that $c_3 = 1$. Then, in the local equation $(u, v, w) = (-y', 1, y'x - y)$ for the dual curve, $u = -3x^2 + \dots$ and $w = 2x^3 + \dots$. Proposition 1.8.11 tells us that the singularity at the origin is a cusp. \square

1.11 The Plücker Formulas

Recall (1.10.12) that a plane curve C is *ordinary* if it is smooth, all of its bitangents and flex points are ordinary (see (1.10.11)), and there are no accidents. The *Plücker formulas* compute the number of flexes and bitangents of an ordinary plane curve. plucker

1.11.1. Theorem: Plücker Formulas. *Let C be an ordinary curve of degree d at least two, and let C^* be its dual curve. Let f and b denote the numbers of flex points and bitangents of C , and let d^* , δ^* and κ^* denote the degree, the numbers of nodes, and the number of cusps of C^* , respectively. Then:* plform

(i) *The dual curve C^* has no flexes or bitangents. Its singularities are nodes and cusps.*

(ii) $d^* = d^2 - 2$, $f = \kappa^* = 3d(d - 2)$, and $b = \delta^* = \frac{1}{2}d(d - 2)(d^2 - 9)$.

proof. (i) A bitangent or a flex on C^* would produce a singularity on the bidual C^{**} , which is the smooth curve C .

(ii) The degree d^* was computed in Corollary 1.8.26. Bézout's Theorem counts the flex points (see (1.10.6)). The facts that $\kappa^* = f$ and $\delta^* = b$ are dealt with in Proposition 1.10.14. Thus $\kappa^* = f = 3d(d - 2)$.

When we project C^* to \mathbb{P}^1 from a generic point s of \mathbb{P}^* . The number of branch points that correspond to tangent lines through s at smooth points of C^* is the degree d of $C^{**} = C$ (see (1.8.26)).

Next, let F be the defining polynomial for C^* . The discriminant $\text{Discr}_z(F)$ has degree $d^{*2} - d^*$. Proposition 1.9.10 describes the order of vanishing of the discriminant at the images of the d tangent lines through s , the δ nodes of C^* , and the κ cusps of C^* . It tells us that

$$d^{*2} - d^* = d + 2\delta^* + 3\kappa^*$$

Substituting the known values $d^* = d^2 - d$, and $\kappa^* = 3d(d - 2)$ into this formula gives us

$$(d^2 - d)^2 - (d^2 - d) = d + 2\delta^* + 9d(d - 2) \quad \text{or} \quad 2\delta^* = d^4 - 2d^3 - 9d^2 + 18d \quad \square$$

Note. It isn't easy to count the number of bitangents directly.

1.11.2. Examples.

(i) All curves of degree 2 and all smooth curves of degree 3 are ordinary. some-

(ii) A curve of degree 2 has no flexes and no bitangents. Its dual curve has degree 2. plucker-

(iii) A smooth curve of degree 3 has 9 flexes and no bitangents. Its dual curve has degree 6. formulas

(iv) An ordinary curve C of degree 4 has 24 flexes and 28 bitangents. Its dual curve has degree 12. \square

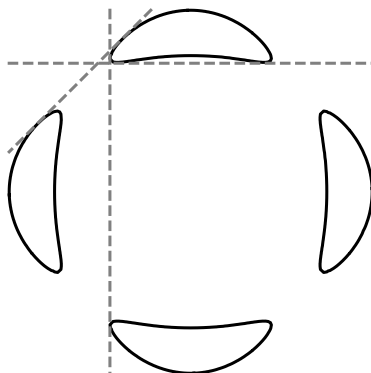

A Real Quartic Curve that has 28 Real Bitangents

To obtain the equation of this quartic, one adds a small constant to the product of the quadratic equations of two ellipses. The equation might be

$$(ax^2 + by^2 - 1)(bx^2 + zy^2 - 1) + c = 0$$

with $a, b, c > 0$.

We will make use of the fact that a quartic curve has 28 bitangents in Chapter 4 (see (4.7.16)). The Plücker Formulas are rarely used for curves of degree greater than four.

1.12 Exercises

1.12.1. Let $f(x, y, z)$ be an homogeneous polynomial of degree greater than one. Prove that the locus $f = 0$ in \mathbb{P}^2 contains three points that do not lie on a line.

chconic

1.12.2. Prove that a plane curve contains infinitely many points.

exinf-
points
xsin

1.12.3. Prove that the path $x(t) = t, y(t) = \sin t$ doesn't lie on any plane algebraic curve in \mathbb{A}^2 .

1.12.4. Using counting constants, prove that most (nonhomogeneous) polynomials in two or more variables are irreducible.

xtwovarirred

1.12.5. Prove that all affine conics can be put into one of the forms 1.1.6 by linear change of variable, translation, and scalar multiplication.

xaffcon-
ictwo

1.12.6. Figure 1.2.11 doesn't give enough information to determine the equation of the conic that is depicted there. What can be deduced about the equation by looking at this figure?

xconicin-
fig

1.12.7. (a) Classify conics in \mathbb{P}^2 by writing an irreducible quadratic polynomial in three variables in the form $X^t A X$ where A is symmetric, and diagonalizing the quadratic form.

xdiagform

(b) Quadrics in \mathbb{P}^3 are zero sets of irreducible homogeneous quadratic polynomials in four variables. Classify quadrics in \mathbb{P}^3 .

1.12.8. Let f and g be irreducible homogeneous polynomials in x, y, z . Prove that if the loci $\{f = 0\}$ and $\{g = 0\}$ are equal, then $g = cf$.

xlociequal

1.12.9. Let C be the plane projective curve defined by the equation $x_0x_1 + x_1x_2 + x_2x_0 = 0$, and let p be the point $(-1, 2, 2)$. What is the equation of the tangent line to C at p ?

xtanconic

1.12.10. Let C be a smooth cubic curve in \mathbb{P}^2 , and let p be a flex point of C . Choose coordinates so that p is the point $(0, 1, 0)$ and the tangent line to C at p is the line $\{z = 0\}$.

xeqforcu-
bic

(a) Show that the coefficients of x^2y, xy^2 , and y^3 in the defining polynomial f of C are zero.

(b) Show that with a suitable choice of coordinates, one can reduce the defining polynomial to the form $f = y^2z + x^3 + axz^2 + bz^3$, and that $x^3 + ax + b$ will be a polynomial with distinct roots.

(c) Show that one of the coefficients a or b can be eliminated, and therefore that smooth cubic curves in \mathbb{P}^2 depend on just one parameter.

1.12.11. Let p be a smooth point of a projective curve X , and suppose that coordinates are chosen so that $p = (0, 0, 1)$ and the tangent line ℓ is the line $\{x_1 = 0\}$. Prove that p is a flex point if and only if the Hessian determinant is zero by computing the Hessian.

xflexhess

1.12.12. Using Euler's formula together with row and column operations, show that the Hessian determinant is equal to $a \det H'$, where

exhessian

$$a = \left(\frac{d-1}{x_0}\right)^2, \quad H' = \begin{pmatrix} cf & f_1 & f_2 \\ f_1 & f_{11} & f_{12} \\ f_2 & f_{21} & f_{22} \end{pmatrix}, \quad \text{and} \quad c = \frac{d}{d-1}$$

1.12.13. Let f a homogeneous polynomial in x, y, z , not a power of z . Prove that f is irreducible if and only if $f(x, y, 1)$ is irreducible.

exs-
taysirre-
ducible
excoord-
triangle

1.12.14. Describe the points that lie in the interior of the coordinate triangle in the real projective space.

1.12.15. Prove that the elementary symmetric functions $s_1 = x_1 + \cdots + x_n, \dots, s_n = x_1 \cdots x_n$ are algebraically independent.

xsymmfmin-
dep
xtdadds

1.12.16. Let $tr(K/F)$ denote the transcendence degree of a field extension K/F . Prove that, if $L \supset K \supset F$ are fields, then $tr(L/F) = tr(L/K) + tr(L/F)$.

1.12.17. Let $f(x_0, x_1, x_2)$ be a homogeneous polynomial of degree d , and let $f_i = \frac{\partial f}{\partial x_i}$, and let C be the plane curve $\{f = 0\}$. Use the following method to prove that the image in the dual plane of the set of smooth points of C is contained in a curve C^* : Let $N_r(k)$ be the dimension of the space of polynomials of degree $\leq k$ in r variables. Determine $N_r(k)$ for $r = 3$ and 4. Show that $N_4(k) > N_3(kd)$ if k is sufficiently large. Use this fact to prove that there is a nonzero polynomial $G(x_0, x_1, x_2)$ such that $G(f_0, f_1, f_2) = 0$.

xdualis-
curve

- xprojcurve **1.12.18.** Let X and Y be the surfaces in $\mathbb{A}_{x,y,z}^3$ defined by the equations $z^3 = x^2$ and $yz^2 + z + y = 0$, respectively. The intersection $C = X \cap Y$ is a curve. Determine the equation of the projection of C to the x, y -plane.
- exercres-
formula
xresfgh **1.12.19.** Compute the resultant of the polynomials x^m and $x^n - 1$.
- 1.12.20.** Let f, g , and h be polynomials. Prove that
(i) $\text{Res}(f, gh) = \text{Res}(f, g) \text{Res}(f, h)$.
(ii) If the degree of gh is less than or equal to the degree of f , then $\text{Res}(f, g) = \text{Res}(f + gh, g)$.
- exres **1.12.21.** With notation as in 1.7.2, suppose that a_0 and b_0 are not zero, and let α_i and β_j be the roots of $f(x, 1)$ and $g(x, 1)$, respectively. Then $\text{Res}(f, g) = a_0^n b_0^m \prod (\alpha_i - \beta_j)$.
- gener-
alline
xrest-
wopol **1.12.22.** Prove that a general line meets a plane projective curve of degree d in d distinct points.
- 1.12.23.** Let $f = x^2 + xz + yz$ and $g = x^2 + y^2$. Compute the resultant $\text{Res}_x(f, g)$ with respect to the variable x .
- 1.12.24.** Compute $\prod_{i \neq j} (\zeta^i - \zeta^j)$ when $\zeta = e^{2\pi i/n}$.
- xsignindisc
xsign **1.12.25.** If $F(x) = \prod (x - \alpha_i)$, then $\text{Discr}(F) = \pm \prod_{i < j} (\alpha_i - \alpha_j)^2$. Determine the sign.
- etdegres **1.12.26.** Let $f = a_0 x^m + a_1 x^{m-1} + \cdots + a_m$ and $g = b_0 x^n + b_1 x^{n-1} + \cdots + b_n$, and let $R = \text{Res}(f, g)$ be the resultant of these polynomials. Prove that
(i) R is a polynomial that is homogeneous in each of the sets of variables a and b , and determine its degree.
(ii) If one assigns weighted degree i to the coefficients a_i and b_i , then R is homogeneous, of weighted degree mn .
- xamap **1.12.27.** Let coordinates in \mathbb{A}^4 be x, y, z, w , let Y be the variety defined by $z^2 = x^2 - y^2$ and $w(z - x) = 1$, and let π denote projection from Y to (x, y) -space. Describe the fibres and the image of π .
- xthrepts **1.12.28.** Prove that a plane curve X of degree 4 can have at most three singular points. Begin by showing that there is a conic C that passes through any five points of X .
- excusptan **1.12.29.** Let p be a cusp of the curve C defined by a homogeneous polynomial f . Prove that there is just one line L through p such that the restriction of f to L has as zero of order > 2 at p , and that the order of zero for that line is precisely 3.
- xhensel **1.12.30.** Let $p(t, x) = x^3 + x^2 + t$. Then $p(0, x) = x^2(x + 1)$. Since x^2 and $x + 1$ are relatively prime, Hensel's Lemma predicts that p factors: $p = fg$, where f and g are polynomials in x whose coefficients are analytic functions in t , and f is monic, $f(0, x) = x^2$, and $g(0, x) = x + 1$. Determine this factorization up to degree 3 in t . Do the same for the polynomial $tx^4 + x^3 + x^2 + t$.
- 1.12.31.** Let $f(t, y) = ty^2 - 4y + t$.
- xxhensellemma (i) Solve $f = 0$ for y by the quadratic formula, and sketch the real locus $f = 0$ in the t, y plane.
(ii) What does Hensel's Lemma say tell us?
(iii) Factor f , modulo t^4 .
- 1.12.32.** Factor $f(t, x) = x^3 + 2tx^2 + t^2x + x + t$, modulo t^2 .
- xxhensellem-
xintconic
matwo **1.12.33.** By parametrizing a conic C , show that C meets a plane curve X of degree d and distinct from C in $2d$ points, when counted with multiplicity.
- cus-
pcurved-
ual
geometry-
ofnode
xdualnode **1.12.34.** Determine the degree of the dual of a plane cubic curve C with a cusp using a generic projection to \mathbb{P}^1 .
- 1.12.35.** Describe the intersection of the node $xy = 0$ at the origin with the unit sphere in \mathbb{A}^2 .
- 1.12.36.** Let C be a cubic curve with a node. Determine the degree of the dual curve C^* , and the numbers of flexes, bitangents, nodes, and cusps of C and of C^* .
- xtangentq **1.12.37.** Let C be a smooth cubic curve in the plane \mathbb{P}^2 , and let q be a generic point of \mathbb{P}^2 . How many lines through q are tangent lines to C ?

1.12.38. Determine the degree of the dual of a plane cubic curve C with a cusp using a generic projection to \mathbb{P}^1 .

cus-
pcurved-
ual
Cstarcount

1.12.39. Let C be the curve defined by a homogeneous polynomial f of degree d . To prove that the images in the dual plane of the smooth points of C lie on a curve C^* , we used transcendence degree to conclude that there is a polynomial $G(t, s_0, s_1, s_2)$ such that $G(f, f_0, f_1, f_2)$ is identically zero. Use the following method to give an alternate proof: Determine the dimensions $N_r(k)$ of the spaces of polynomials of degree $\leq k$ in r variables, for $r = 3$ and $r = 4$. Show that $N_4(k) > N_3(kd)$ if k is large enough. Use counting constants to show that there has to be a polynomial G that maps to zero by the substitution.

Note: This method doesn't give a good bound for the degree of C^* . One reason may be that f and its derivatives are related by Euler's Formula. It is tempting try using Euler's Formula to help compute the equation of C^* , but I haven't succeeded in getting anywhere that way.

1.12.40. Prove that the Fermat curve $C : \{x^d + y^d + z^d = 0\}$ is connected by studying its projection to \mathbb{P}^1 from the point $(0, 0, 1)$.

fermat-
conn

Chapter 2 AFFINE ALGEBRAIC GEOMETRY

affine

- 2.1 Rings and Modules
- 2.2 The Zariski Topology
- 2.3 Some Affine Varieties
- 2.4 The Nullstellensatz
- 2.5 The Spectrum
- 2.6 Localization
- 2.7 Morphisms of Affine Varieties
- 2.8 Finite Group Actions

We study varieties of arbitrary dimension in the next chapters. We will use some of the basic terminology that was introduced in Chapter 1, including the concepts of discriminant and transcendence degree, but most of the results of Chapter 1 won't be needed until Chapter 8.

To begin, we review some basic facts about rings and modules, omitting proofs. Please look up information on the concepts that aren't familiar, as needed.

2.1 Rings and Modules

ringreview

By the word 'ring', we mean 'commutative ring': $ab = ba$, unless the contrary is stated explicitly. A *domain* is a ring that has no zero divisors and isn't the zero ring. As before, an *algebra* is a ring that contains the field \mathbb{C} of complex numbers as a subring.

A set of elements $\alpha = \{\alpha_1, \dots, \alpha_n\}$ *generates* an algebra A if every element of A can be expressed (usually not uniquely) as a polynomial in $\alpha_1, \dots, \alpha_n$, with complex coefficients. Another way to state this is that α generates A if the homomorphism $\mathbb{C}[x_1, \dots, x_n] \xrightarrow{\tau} A$ that evaluates a polynomial at $x = \alpha$ is surjective. If α generates A , then A will be isomorphic to the quotient $\mathbb{C}[x]/I$ of the polynomial algebra $\mathbb{C}[x]$, where I is the kernel of τ . An algebra that can be generated by a finite set of elements is a *finite-type algebra*.

If I and J are ideals of a ring R , the *product ideal*, which is denoted by IJ , is the ideal whose elements are finite sums of products $\sum a_i b_i$, with $a_i \in I$ and $b_i \in J$. The product ideal isn't the product set, whose elements are the products ab with $a \in I$ and $b \in J$. The *power* I^k of I is the product of k copies of I – the ideal spanned by products of k elements of I .

The intersection $I \cap J$ is also an ideal, and

intersect-product

$$(2.1.1) \quad (I \cap J)^2 \subset IJ \subset I \cap J$$

An ideal M of a ring R is a *maximal ideal* if it isn't the unit ideal R , and if there is no ideal I such that $M < I < R$. This will be true if and only if the quotient ring R/M is a field.

An ideal P of a ring R is a *prime ideal* if the quotient R/P is a domain. A maximal ideal is a prime ideal.

invim-prime

2.1.2. Lemma. *Let $A \xrightarrow{\varphi} B$ be a ring homomorphism. The inverse image of a prime ideal of B is a prime ideal of A .*

proof. Let P be the inverse image of a prime ideal Q of B . Then P is the kernel of the composed homomorphism $A \rightarrow B \rightarrow B/Q$. The quotient A/P maps injectively to a subring of the domain B/Q . Therefore A/P is a domain. \square

2.1.3. Lemma. Let P be an ideal of a ring R , not the unit ideal. The following conditions are equivalent. defprime

- (i) P is a prime ideal.
- (ii) If a and b are elements of R , and if $ab \in P$, then $a \in P$ or $b \in P$.
- (iii) If A and B are ideals of R , and if the product ideal AB is contained in P , then $A \subset P$ or $B \subset P$. □

It is sometimes convenient to state (iii) this way:

(iii') If A and B are ideals that contain P , and if the product ideal AB is contained in P , then $A = P$ or $B = P$.

2.1.4. Mapping Property of Quotient Rings. Let R and S be rings, let K be an ideal of R , and let $R \xrightarrow{\tau} \bar{R}$ denote the canonical map from R to the quotient ring $\bar{R} = R/K$. Homomorphisms $\bar{R} \xrightarrow{\bar{\varphi}} S$ correspond bijectively to homomorphisms $R \xrightarrow{\varphi} S$ whose kernels contain K , the correspondence being $\varphi = \bar{\varphi} \circ \tau$. mapprop

$$\begin{array}{ccc} R & \xrightarrow{\varphi} & S \\ \tau \downarrow & & \parallel \\ \bar{R} & \xrightarrow{\bar{\varphi}} & S \end{array}$$

If $\ker \varphi = I$, then $\ker \bar{\varphi} = I/K$. □

(2.1.5) commutative diagrams commdiag

In the diagram displayed above, the maps $\bar{\varphi}\tau$ and φ from R to S are equal. This is referred to by saying that the diagram is *commutative*. A commutative diagram is one in which every map that can be obtained by composing its arrows depends only on the domain and range of that map. In these notes, all diagrams of maps are commutative. We won't mention commutativity most of the time. □

2.1.6. Correspondence Theorem. corrthm

(i) Let $R \xrightarrow{\varphi} S$ be a **surjective** ring homomorphism with kernel K . (For instance, φ might be the canonical map from R to the quotient ring R/K .) In any case, S will be isomorphic to R/K .) There is a bijective correspondence

$$\{\text{ideals of } R \text{ that contain } K\} \longleftrightarrow \{\text{ideals of } S\}$$

This correspondence associates an ideal I of R that contains K with its image $\varphi(I)$ in S and it associates an ideal J of S with its inverse image $\varphi^{-1}(J)$ in R .

If an ideal I of R that contains K corresponds to the ideal J of S , then φ induces an isomorphism of quotient rings $R/I \rightarrow S/J$. If one of the ideals, I or J , is prime or maximal, they both are.

(ii) Let R be a ring, and let $M \xrightarrow{\varphi} N$ be a surjective homomorphism of R -modules with kernel L . There is a bijective correspondence

$$\{\text{submodules of } M \text{ that contain } L\} \longleftrightarrow \{\text{submodules of } N\}$$

This correspondence associates a submodule S of M that contains L with its image $\varphi(S)$ in N and it associates a submodule T of N with its inverse image $\varphi^{-1}(T)$ in M . □

Ideals I_1, \dots, I_k of a ring R are said to be *comaximal* if the sum of any two of them is the unit ideal.

2.1.7. Chinese Remainder Theorem. Let I_1, \dots, I_k be comaximal ideals of a ring R . comax

- (i) The product ideal $I_1 \cdots I_k$ is equal to the intersection $I_1 \cap \cdots \cap I_k$.
- (ii) The map $R \rightarrow R/I_1 \times \cdots \times R/I_k$ that sends an element a of R to its vector of residues is a surjective homomorphism, and its kernel is $I_1 \cap \cdots \cap I_k$, which is equal to $I_1 \cdots I_k$.
- (iii) Let M be an R -module. The canonical homomorphism $M \rightarrow (M/I_1M) \times \cdots \times (M/I_kM)$ is surjective. □

quotof-
prod

2.1.8. Proposition. Let R be a product of rings, $R = R_1 \times \cdots \times R_k$, let I be an ideal of R , and let $\bar{R} = R/I$ be the quotient ring. There are ideals I_j of R_j such that $I = I_1 \times \cdots \times I_k$ and $\bar{R} = R_1/I_1 \times \cdots \times R_k/I_k$. \square

noethr

(2.1.9) Noetherian rings

Let M and N be modules over a ring R . By an R -linear map $M \rightarrow N$, we mean a homomorphism of R -modules. When we refer to a map as being linear without mentioning a ring, we mean a \mathbb{C} -linear map.

A finite module M over a ring R is a module that is spanned, or generated, by a finite set $\{m_1, \dots, m_k\}$ of elements. To say that the set generates M means that every element of M can be obtained as a combination $r_1m_1 + \cdots + r_km_k$ with coefficients r_i in R , or that the homomorphism from the free R -module R^k to M that sends a vector (r_1, \dots, r_k) to the combination $r_1m_1 + \cdots + r_km_k$ is surjective.

An ideal of a ring R is *finitely generated* if, when regarded as an R -module, it is a finite module.

A ring R is *noetherian* if all of its ideals are finitely generated. The ring \mathbb{Z} of integers is noetherian. Fields are noetherian. If I is an ideal of a noetherian ring R , the quotient ring R/I is noetherian.

basisthm

2.1.10. Hilbert Basis Theorem. Let R be a noetherian ring. The ring $R[x_1, \dots, x_n]$ of polynomials with coefficients in R is noetherian. \square

Thus $\mathbb{Z}[x_1, \dots, x_n]$ and $F[x_1, \dots, x_n]$, F a field, are noetherian rings.

qnoeth

2.1.11. Corollary. Every finite-type algebra is noetherian. \square

Note. It is important not to confuse the concept of a finite-type algebra with that of a finite module. A finite R -module M is a module in which every element can be written as a (linear) combination $r_1m_1 + \cdots + r_km_k$ of some finite set $\{m_1, \dots, m_k\}$ of elements of M , with coefficients in R . A finite-type algebra A is an algebra which contains a finite set of elements $\{\alpha_1, \dots, \alpha_k\}$, such that every element can be written as a polynomial $f(\alpha_1, \dots, \alpha_k)$, with complex coefficients.

ascchcond

(2.1.12) the ascending chain condition

The condition that a ring R be noetherian can be rewritten in several ways that we review here.

Our convention is that, if X' and X are sets, the notation $X' \subset X$ means that X' is a subset of X , while $X' < X$ means that X' is a subset that is distinct from X . A *proper subset* X' of a set X is a nonempty subset distinct from X – a set such that $\emptyset < X' < X$.

A sequence X_1, X_2, \dots , finite or infinite, of subsets of a set Z forms an *increasing chain* if $X_n \subset X_{n+1}$ for all n , equality $X_n = X_{n+1}$ being permitted. If $X_n < X_{n+1}$ for all n , the chain is *strictly increasing*.

Let \mathcal{S} be a set whose elements are subsets of a set Z . A member M of \mathcal{S} is a *maximal member* if there is no member M' of \mathcal{S} such that $M < M'$. For example, the set of proper subsets of a set of five elements contains five maximal members, the subsets of order four. The set of finite subsets of the set of integers contains no maximal member.

A maximal ideal of a ring R is a maximal member of the set of ideals of R different from the unit ideal.

noether-
conds

2.1.13. Proposition. The following conditions on a ring R are equivalent:

- (i) R is **noetherian**: Every ideal of R is finitely generated.
- (ii) The **ascending chain condition**: Every strictly increasing chain $I_1 < I_2 < \cdots$ of ideals of R is finite.
- (iii) Every nonempty set of ideals of R contains a maximal member. \square

The next corollary follows from the ascending chain condition, but the conclusions are true whether or not R is noetherian.

idealin-
maximal

2.1.14. Corollary. Let R be a noetherian ring.

- (i) If R isn't the zero ring, every ideal of R except the unit ideal is contained in a maximal ideal.
- (ii) A nonzero ring R contains at least one maximal ideal.
- (iii) An element of R that isn't in any maximal ideal is a unit – an invertible element of R . \square

2.1.15. Corollary. Let s_1, \dots, s_k be elements that generate the unit ideal of a ring R . For any positive integer n , the powers s_1^n, \dots, s_k^n generate the unit ideal.

powers-generate

proof. When s_1, \dots, s_k generate the unit ideal, there will be an equation of the form $1 = \sum r_i s_i$, and for any N , $1 = 1^N = (\sum r_i s_i)^N$. If $N \geq nk$, then when the right side is expanded, every term will be divisible by s_i^n for some n . \square

2.1.16. Proposition. Let R be a noetherian ring, and let M be a finite R -module.

noetherian-module

(i) Every submodule of M is a finite module.

(ii) The set of submodules of M satisfies the ascending chain condition.

(iii) Every nonempty set of submodules of M contains a maximal member. \square

This concludes our review of rings and modules.

2.2 The Zariski Topology

The affine space \mathbb{A}^n is the space of n -tuples (a_1, \dots, a_n) of complex numbers, as before.

zartop

Algebraic geometry studies polynomial equations in terms of their solutions in affine space.

Let f_1, \dots, f_k be polynomials in x_1, \dots, x_n . The set of points of \mathbb{A}^n that solve the system of equations

$$(2.2.1) \quad f_1 = 0, \dots, f_k = 0$$

fequat

the locus of zeros of f , is a Zariski closed subset of \mathbb{A}^n . A subset U of \mathbb{A}^n is a Zariski open subset if its complement, the set of points not in U , is Zariski closed.

The locus of solutions of the equations $f = 0$ may be denoted by $V(f_1, \dots, f_k)$ or by $V(f)$. Its points are called the zeros of the polynomials f . We use analogous notation for infinite sets. If \mathcal{F} is any set of polynomials, $V(\mathcal{F})$ denotes the set of points of affine space at which all elements of \mathcal{F} are zero. In particular, if I is an ideal of the polynomial ring, $V(I)$ denotes the set of points at which all elements of I vanish.

The ideal I of $\mathbb{C}[x]$ that is generated by the polynomials f_1, \dots, f_k is the set of combinations $r_1 f_1 + \dots + r_k f_k$ with polynomial coefficients r_i . Some notations for this ideal are (f_1, \dots, f_k) and (f) . All elements of I vanish on the zero set $V(f)$, so $V(f) = V(I)$. The Zariski closed subsets of \mathbb{A}^n can be described as the sets $V(I)$, where I is an ideal.

We note a few simple relations among ideals and their zero sets here. To begin with, we note that an ideal I isn't determined by its zero locus $V(I)$. For any $k > 0$, the power f^k of a polynomial f has the same zeros as f .

The radical of an ideal I of a ring R , which will be denoted by $\text{rad } I$, is the set of elements α of R such that some power α^r is in I .

$$(2.2.2) \quad \text{rad } I = \{\alpha \in R \mid \alpha^r \in I \text{ for some } r > 0\}$$

raddef

The radical of I is an ideal that contains I .

An ideal that is equal to its radical is a radical ideal. A prime ideal is a radical ideal.

2.2.3. Lemma. If I is an ideal of the polynomial ring $\mathbb{C}[x]$, then $V(I) = V(\text{rad } I)$. \square

VradI

Consequently, if I and J are ideals and if $\text{rad } I = \text{rad } J$, then $V(I) = V(J)$. The converse of this statement is also true: If $V(I) = V(J)$, then $\text{rad } I = \text{rad } J$. This is a consequence of the Strong Nullstellensatz that will be proved later in this chapter (see (2.4.9)).

Because $(I \cap J)^2 \subset IJ \subset I \cap J$,

$$(2.2.4) \quad \text{rad}(IJ) = \text{rad}(I \cap J)$$

radIJ

Also, $\text{rad}(I \cap J) = (\text{rad } I) \cap (\text{rad } J)$.

2.2.5. Lemma. Let I and J be ideals of the polynomial ring $\mathbb{C}[x]$.

linJ

(i) If $I \subset J$, then $V(I) \supset V(J)$.

(ii) $V(I^k) = V(I)$.

(iii) $V(I \cap J) = V(IJ) = V(I) \cup V(J)$.

(iv) If I_ν are ideals, then $V(\sum I_\nu) = \bigcap V(I_\nu)$.

proof. (iii) $V(I \cap J) = V(IJ)$ because the two ideals have the same radical, and because I and J contain IJ , $V(IJ) \supset V(I) \cup V(J)$. To prove that $V(IJ) \subset V(I) \cup V(J)$, we note that $V(IJ)$ is the locus of common zeros of the products fg with f in I and g in J . Suppose that a point p is a common zero: $f(p)g(p) = 0$ for all f in I and all g in J . If $f(p) \neq 0$ for some f in I , we must have $g(p) = 0$ for every g in J , and then p is a point of $V(J)$. On the other hand, if $f(p) = 0$ for all f in I , then p is a point of $V(I)$. In either case, p is a point of $V(I) \cup V(J)$. \square

The Zariski closed sets defined above are the closed sets in the *Zariski topology* on \mathbb{A}^n , a topology that is very useful in algebraic geometry, though it is very different from the classical topology.

To verify that the Zariski closed sets are the closed sets of a topology, one must show that

- the empty set and the whole space are Zariski closed,
- the intersection $\bigcap C_\nu$ of an arbitrary family of Zariski closed sets is Zariski closed, and
- the union $C \cup D$ of two Zariski closed sets is Zariski closed.

The empty set and the whole space are the zero sets of the elements 1 and 0, respectively. The other conditions follow from Lemma 2.2.5. \square

ztopdi-
mone

2.2.6. Example. The proper Zariski closed subsets of the affine line, or of a plane affine curve, are the nonempty finite sets. The proper Zariski closed subsets of the affine plane are finite unions of points and curves. Let's omit the proofs of these facts. The corresponding facts for loci in the projective line and the projective plane have been noted before. (See (1.3.4) and (1.3.14).) \square

zarclosed-
fig

2.2.7.

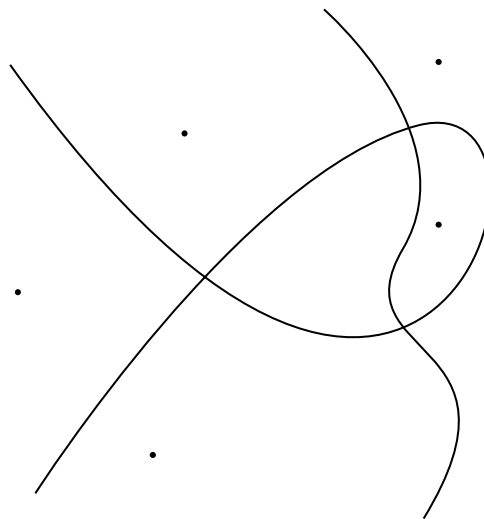

A Zariski closed subset of the affine plane (real locus)

figure

A subset S of a topological space X becomes a topological space with the *induced topology*. The closed (or open) subsets of S in the induced topology are intersections $S \cap Y$, where Y is closed (or open) in X .

The induced topology on a subset S of \mathbb{A}^n is called the *Zariski topology* too. A subset of S is closed in the Zariski topology if it has the form $S \cap Y$ for some Zariski closed subset Y of \mathbb{A}^n . If S itself is a Zariski closed subset of \mathbb{A}^n , a closed subset of S can be described as a closed subset of \mathbb{A}^n that is contained in S .

Affine space also has a *classical topology*, that was defined in Chapter 1. A subset U of \mathbb{A}^n is open in the classical topology if, whenever a point p is in U , all points sufficiently near to p are in U . Since polynomial

functions are continuous, their zero sets are closed in the classical topology. Therefore Zariski closed sets are closed in the classical topology too.

When two topologies T and T' on a set X are given, T' is said to be *coarser* than T if T' contains fewer closed sets or fewer open sets than T , and T' *finer* than T if it contains more closed sets or more open sets than T . The Zariski topology is coarser than the classical topology. As the next proposition shows, it is much coarser.

2.2.8. Proposition. *Any nonempty Zariski open subset U of \mathbb{A}^n is dense and path connected in the classical topology.* opendense

proof. The (complex) line L through distinct points p and q of \mathbb{A}^n is a Zariski closed set whose points can be written as $p + t(q - p)$, with t in \mathbb{C} . It corresponds bijectively to the one-dimensional affine t -space \mathbb{A}^1 , and the Zariski closed subsets of L correspond to Zariski closed subsets of \mathbb{A}^1 . They are the finite subsets, and L itself.

Let U be a nonempty Zariski open set, and let C be its Zariski closed complement. To show that U is dense in the classical topology, we choose distinct points p and q of \mathbb{A}^n , with p in U . If L is the line through p and q , $C \cap L$ will be a Zariski closed subset of L , a finite set, that doesn't contain p . Its complement is $U \cap L$. In the classical topology, the closure of $U \cap L$, will be the whole line L . It contains q . Then the closure of U contains q , and since q was arbitrary, the closure of U is \mathbb{A}^n .

Next, let L be the line through two points p and q of U . As before, $C \cap L$ will be a finite set of points. In the classical topology, L is a complex plane. The points p and q can be joined by a path in L that avoids this finite set. □

Though we will use the classical topology from time to time, the Zariski topology will appear more often. For this reason, we will refer to a Zariski closed subset simply as a *closed set*. Similarly, by an *open set* we mean a Zariski open set. We will mention the adjective "Zariski" only for emphasis.

(2.2.9) irreducible closed sets irrclosed

The fact that the polynomial algebra is a noetherian ring has important consequences for the Zariski topology that we discuss here.

A topological space X satisfies the *descending chain condition* on closed subsets if X has no infinite, strictly descending chain $C_1 > C_2 > \dots$ of closed subsets. The descending chain condition on closed subsets is equivalent with the *ascending chain condition* on open sets.

A topological space that satisfies the descending chain condition on closed sets is called a *noetherian space*. In a noetherian space, every nonempty family \mathcal{S} of closed subsets has a minimal member, one that doesn't contain any other member of \mathcal{S} , and every nonempty family of open sets has a maximal member. (See (2.1.12).)

2.2.10. Lemma. *A noetherian topological space is **quasicompact**, that is, every open covering has a finite subcovering.* noethq-comp

2.2.11. Proposition. *With its Zariski topology, \mathbb{A}^n is a noetherian space.* deschain

proof. Suppose that a strictly descending chain $C_1 > C_2 > \dots$ of closed subsets of \mathbb{A}^n is given. Let I_j be the ideal of all elements of the polynomial ring $\mathbb{C}[x_1, \dots, x_n]$ that are identically zero on C_j . Then $C_j = V(I_j)$. Since $C_j > C_{j+1}$, $V(I_j) > V(I_{j+1})$, and therefore $I_j < I_{j+1}$. The ideals I_j form a strictly increasing chain. Since $\mathbb{C}[x_1, \dots, x_n]$ is noetherian, this chain is finite. Therefore the strictly decreasing chain C_j is finite too. □

2.2.12. Definition. A topological space X is *irreducible* if it isn't the union of two proper closed subsets. de-firrspace

Another way to say that a topological space X is irreducible is this:

2.2.13. *If C and D are closed subsets of X , and if $X = C \cup D$, then $X = C$ or $X = D$.* ir-redspacetwo

The concept of irreducibility is useful primarily for noetherian spaces. The only irreducible subsets of a Hausdorff space are its points. In particular, with the classical topology, the only irreducible subsets of affine space are points.

Irreducibility is somewhat analogous to connectedness. A topological space is *connected* if it isn't the union $C \cup D$ of two proper *disjoint* closed subsets. However, the condition that a space be irreducible is much more restrictive because, in Definition 2.2.12, the closed sets C and D aren't required to be disjoint. In the Zariski topology on the affine plane, lines are irreducible closed sets. The union of two intersecting lines is connected, but not irreducible.

ir-
redlemma

2.2.14. Lemma. *The following conditions on topological space X are equivalent.*

- X is irreducible.
- The intersection $U \cap V$ of two nonempty open subsets U and V of X is nonempty.
- Every nonempty open subset U of X is dense (its closure is X). □

unionirred

2.2.15. Theorem. *In a noetherian topological space, every closed subset is the union of finitely many irreducible closed sets.*

proof. If a closed subset C_0 of a topological space X isn't a union of finitely many irreducible closed sets, then it isn't irreducible, so it is a union $C_1 \cup D_1$, where C_1 and D_1 are proper closed subsets of C_0 , and therefore closed subsets of X . Since C_0 isn't a finite union of irreducible closed sets, C_1 and D_1 cannot both be finite unions of irreducible closed sets. Say that C_1 isn't such a union. We have the beginning $C_0 > C_1$ of a chain of closed subsets. We repeat the argument, replacing C_0 by C_1 , and we continue in this way, to construct an infinite, strictly descending chain $C_0 > C_1 > C_2 > \dots$. So X isn't a noetherian space. □

defadffvar

2.2.16. Definition. An *affine variety* is an irreducible closed subset of affine space \mathbb{A}^n .

Theorem 2.2.15 tells us that every closed subset of \mathbb{A}^n is a finite union of affine varieties. Since an affine variety is irreducible, it is connected in the Zariski topology. It is also connected in the classical topology, but this isn't very easy to prove. We may not get to the proof.

The *closure* of a subset S of a topological space X is the smallest closed subset that contains S . The closure exists because it is the intersection of all closed subsets that contain S .

quasicom-
pact

2.2.17. Lemma. (i) *Let Z be a subspace of a topological space X , let S be a subset of Z , and let \bar{S} denote the closure of S in X . The closure of S in Z is the intersection $\bar{S} \cap Z$.*

(ii) *Let \bar{Z} be the closure of a subspace Z of a topological space X . Then \bar{Z} is irreducible if and only if Z is irreducible.*

(iii) *A nonempty open subspace W of an irreducible space X is irreducible.*

proof. (ii) Let Z be an irreducible subset of X , and suppose that its closure \bar{Z} is the union $\bar{C} \cup \bar{D}$ of two closed sets \bar{C} and \bar{D} . Then Z is the union of the sets $C = \bar{C} \cap Z$ and $D = \bar{D} \cap Z$, and they are closed in Z . Therefore Z is one of those two sets; say $Z = C$. Then $Z \subset \bar{C}$, and since \bar{C} is closed, $\bar{Z} \subset \bar{C}$. Because $\bar{C} \subset \bar{Z}$ as well, $\bar{C} = \bar{Z}$. Conversely, suppose that the closure \bar{Z} of a subset Z of X is irreducible, and that Z is a union $C \cup D$ of closed subsets. Then $\bar{Z} = \bar{C} \cup \bar{D}$, and therefore $\bar{Z} = \bar{C}$ or $\bar{Z} = \bar{D}$, say $\bar{Z} = \bar{C}$. So $Z = \bar{C} \cap Z = C$. Then C is not a proper subset.

(iii) The closure of W is the irreducible space X . □

noethind

(2.2.18) noetherian induction

In a noetherian space X one may be able to use *noetherian induction* in proofs. Suppose that a statement \mathcal{S} is to be proved for every nonempty closed subset of X . Then it suffices to prove it for X under the assumption that \mathcal{S} is true for every proper closed subset of X .

Moreover, to prove a statement \mathcal{S} for every affine variety X , it is permissible to prove it for X under the assumption that \mathcal{S} is true for every proper closed subvariety of X .

The justification of noetherian induction is similar to the justification of complete induction. □

coordi-
nategebra

(2.2.19) the coordinate algebra of a variety

2.2.20. Proposition. *The affine varieties in \mathbb{A}^n are the sets $V(P)$, where P is a prime ideal of the polynomial algebra $\mathbb{C}[x] = \mathbb{C}[x_1, \dots, x_n]$. If P is a radical ideal, then $V(P)$ is an affine variety if and only if P is a prime ideal.* irredprime

We will use this proposition in the next section, where we give a few examples of varieties, but we defer the proof to Section 2.5, where the proposition will be proved in a more general form. (See Proposition 2.5.12.)

As before, an *algebra* is a ring that contains the complex numbers.

2.2.21. Definition. Let P be a prime ideal of the polynomial ring $\mathbb{C}[x_1, \dots, x_n]$, and let V be the affine variety $V(P)$ in \mathbb{A}^n . The *coordinate algebra* of V is the quotient algebra $A = \mathbb{C}[x]/P$. defco-
ordalg

Geometric properties of the variety are reflected in algebraic properties of its coordinate algebra and vice versa. In a primitive sense, one can regard the geometry of an affine variety V as given by closed subsets and incidence relations – the inclusion of one closed set into another, as when a point lies on a line. A finer study of the geometry takes into account other things tangency for instance, but it is reasonable to begin by studying incidences $C' \subset C$ among closed subvarieties. Such incidences translate into inclusions $P' \supset P$ in the opposite direction among prime ideals.

2.3 Some affine varieties

This section contains a few simple examples of varieties. somevari-
eties
ptvar

2.3.1. A point $p = (a_1, \dots, a_n)$ of affine space \mathbb{A}^n is the set of solutions of the n equations $x_i - a_i = 0$, $i = 1, \dots, n$. A point is a variety because the polynomials $x_i - a_i$ generate a maximal ideal in the polynomial algebra $\mathbb{C}[x]$, and a maximal ideal is a prime ideal. We denote the maximal ideal that corresponds to the point p by \mathfrak{m}_p . It is the kernel of the substitution homomorphism $\pi_p : \mathbb{C}[x] \rightarrow \mathbb{C}$ that evaluates a polynomial $g(x_1, \dots, x_n)$ at p : $\pi_p(g(x)) = g(a_1, \dots, a_n) = g(p)$. As here, we denote the homomorphism that evaluates a polynomial at p by π_p .

The coordinate algebra of a point p is the quotient algebra $\mathbb{C}[x]/\mathfrak{m}_p$. It is also called the *residue field* at p , and it will be denoted by $k(p)$. The residue field $k(p)$ is isomorphic to the image of π_p , which is the field \mathbb{C} of complex numbers, but it is a particular quotient of the polynomial ring.

2.3.2. The varieties in the affine line \mathbb{A}^1 are its points, and the whole line \mathbb{A}^1 . The varieties in the affine plane \mathbb{A}^2 are its points, the plane affine curves, and the whole plane. varinline

This is true because the varieties correspond to the prime ideals of the polynomial ring. The prime ideals of $\mathbb{C}[x_1, x_2]$ are the maximal ideals, the principal ideals generated by irreducible polynomials, and the zero ideal. The proof of this is an exercise.

2.3.3. The set X of solutions of a single irreducible polynomial equation $f_1(x_1, \dots, x_n) = 0$ in \mathbb{A}^n is a variety that is called an *affine hypersurface*. hsurf

For instance, the *special linear group* SL_2 , the group of complex 2×2 matrices with determinant 1, is a hypersurface in \mathbb{A}^4 . It is the locus of zeros of the irreducible polynomial $x_{11}x_{22} - x_{12}x_{21} - 1$.

The reason that an affine hypersurface is a variety is that an irreducible element of a unique factorization domain is a prime element, and a prime element generates a prime ideal. The polynomial ring $\mathbb{C}[x_1, \dots, x_n]$ is a unique factorization domain.

2.3.4. A hypersurface in the affine plane \mathbb{A}^2 is a plane affine curve. apc

A *line* in the plane, the locus of a linear equation $ax + by - c = 0$, is a plane affine curve. Its coordinate algebra is isomorphic to a polynomial ring in one variable. Every line is isomorphic to the affine line \mathbb{A}^1 .

2.3.5. Let $p = (a_1, \dots, a_n)$ and $q = (b_1, \dots, b_n)$ be distinct points of \mathbb{A}^n . The *point pair* (p, q) is the closed set defined by the system of n^2 equations $(x_i - a_i)(x_j - b_j) = 0$, $1 \leq i, j \leq n$. A point pair isn't a variety because the ideal I that is generated by the polynomials $(x_i - a_i)(x_j - b_j)$ isn't a prime ideal. The next proposition, which follows from the Chinese Remainder Theorem 2.1.7, describes that ideal. pointpr

2.3.6. Proposition. *The ideal I of polynomials that vanish on a point pair p, q is the product $\mathfrak{m}_p\mathfrak{m}_q$ of the maximal ideals at the points, and the quotient algebra $\mathbb{C}[x]/I$ is isomorphic to the product algebra $\mathbb{C} \times \mathbb{C}$. \square* pointpair

2.4 Hilbert's Nullstellensatz

nullone

2.4.1. Nullstellensatz (version 1). Let $\mathbb{C}[x]$ be the polynomial algebra in the variables x_1, \dots, x_n . There are bijective correspondences between the following sets:

- points p of the affine space \mathbb{A}^n ,
- algebra homomorphisms $\pi_p : \mathbb{C}[x] \rightarrow \mathbb{C}$,
- maximal ideals \mathfrak{m}_p of $\mathbb{C}[x]$.

If $p = (a_1, \dots, a_n)$ is a point of \mathbb{A}^n , the homomorphism π_p evaluates a polynomial at p : $\pi_p(g) = g(a_1, \dots, a_n) = g(p)$. The maximal ideal \mathfrak{m}_p is the kernel of π_p . It is the ideal generated by the linear polynomials $x_1 - a_1, \dots, x_n - a_n$. \square

It is obvious that every algebra homomorphism $\mathbb{C}[x] \rightarrow \mathbb{C}$ is surjective, and that its kernel is a maximal ideal. It isn't obvious that every maximal ideal of $\mathbb{C}[x]$ is the kernel of such a homomorphism. The proof can be found manywhere.¹

The Nullstellensatz gives us a way to describe the closed set $V(I)$ of zeros of an ideal I in affine space in terms of maximal ideals. The points of $V(I)$ are those at which all elements of I vanish. They are the points p such that the ideal I is contained in \mathfrak{m}_p .

Thus

$$(2.4.2) \quad V(I) = \{p \in \mathbb{A}^n \mid I \subset \mathfrak{m}_p\}$$

maxide-
alscheme
Empty

2.4.3. Proposition. Let I be an ideal of the polynomial ring $\mathbb{C}[x]$. If the zero locus $V(I)$ is empty, then I is the unit ideal.

proof. Every ideal I that is not the unit ideal is contained in a maximal ideal (Corollary 2.1.14). \square

nulltwo

2.4.4. Nullstellensatz (version 2). Let A be a finite-type algebra. There are bijective correspondences between the following sets:

- algebra homomorphisms $\bar{\pi} : A \rightarrow \mathbb{C}$,
- maximal ideals $\bar{\mathfrak{m}}$ of A .

The maximal ideal $\bar{\mathfrak{m}}$ that corresponds to a homomorphism $\bar{\pi}$ is the kernel of $\bar{\pi}$.

If A is presented as a quotient of a polynomial ring, say $A \approx \mathbb{C}[x_1, \dots, x_n]/I$, then these sets also correspond bijectively to points of the set $V(I)$ of zeros of I in \mathbb{A}^n .

The symbol \approx stands for an isomorphism. As before, a finite-type algebra is an algebra that can be generated by a finite set of elements.

proof. We choose a presentation of A as a quotient of a polynomial ring to identify A with a quotient $\mathbb{C}[x]/I$. The Correspondence Theorem tells us that maximal ideals of A correspond to maximal ideals of $\mathbb{C}[x]$ that contain I . Those maximal ideals correspond to points of $V(I)$.

Let τ denote the canonical homomorphism $\mathbb{C}[x] \rightarrow A$. The Mapping Property 2.1.4, applied to τ , tells us that homomorphisms $A \xrightarrow{\bar{\pi}} \mathbb{C}$ correspond to homomorphisms $\mathbb{C}[x] \xrightarrow{\pi} \mathbb{C}$ whose kernels contain I . Those homomorphisms also correspond to points of $V(I)$.

polyring-
toA

$$(2.4.5) \quad \begin{array}{ccc} \mathbb{C}[x] & \xrightarrow{\pi} & \mathbb{C} \\ \tau \downarrow & & \parallel \\ A & \xrightarrow{\bar{\pi}} & \mathbb{C} \end{array} \quad \square$$

strongnull

2.4.6. Strong Nullstellensatz. Let I be an ideal of the polynomial algebra $\mathbb{C}[x_1, \dots, x_n]$, and let V be the locus of zeros of I in \mathbb{A}^n : $V = V(I)$. If a polynomial $g(x)$ vanishes at every point of V , then I contains a power of g .

¹While writing a paper, the mathematician Nagata decided that the English language needed this unusual word. Then he managed to find it in a dictionary.

proof. This beautiful proof is due to Rainich. Let $g(x)$ be a polynomial that is identically zero on V . We are to show that I contains a power of g . If g is the zero polynomial, it is in I , so we may assume that g isn't zero.

The Hilbert Basis Theorem tells us that I is a finitely generated ideal. Let $f = \{f_1, \dots, f_k\}$ be a set of generators. We introduce a new variable y . Let W be the locus of solutions of the $k+1$ equations

$$(2.4.7) \quad f_1(x) = \dots = f_k(x) = 0 \quad \text{and} \quad g(x)y - 1 = 0 \quad \text{fgy}$$

in the $n+1$ -dimensional affine space with coordinates (x_1, \dots, x_n, y) . Suppose that we have a solution x of the equations $f(x) = 0$, say $(x_1, \dots, x_n) = (a_1, \dots, a_n)$. Then a is a point of V , and our hypothesis tells us that $g(a) = 0$ too. So there can be no b such that $g(a)b = 1$. There is no point (a_1, \dots, a_n, b) that solves the equations (2.4.7): The locus W is empty. Proposition 2.4.3 tells us that the polynomials $f_1, \dots, f_k, gy - 1$ generate the unit ideal of $\mathbb{C}[x_1, \dots, x_n, y]$. There are polynomials $p_1(x, y), \dots, p_k(x, y)$ and $q(x, y)$ such that

$$(2.4.8) \quad p_1 f_1 + \dots + p_k f_k + q(gy - 1) = 1 \quad \text{rabinowitz}$$

The ring $R = \mathbb{C}[x, y]/(gy - 1)$ can be described as the one obtained by adjoining an inverse of g to the polynomial ring $\mathbb{C}[x]$. The residue of y is the inverse of g . Since g isn't zero, $\mathbb{C}[x]$ is a subring of R .

In R , $gy - 1 = 0$. The equation (2.4.8) becomes $p_1 f_1 + \dots + p_k f_k = 1$. When we multiply both sides of this equation by a large power g^N of g , we can use the equation $gy = 1$, which is true in R , to cancel all occurrences of y in the polynomials $p_i(x, y)$. Let $h_i(x)$ denote the polynomial in x that is obtained by cancelling y in $g^N p_i$. Then

$$h_1(x)f_1(x) + \dots + h_k(x)f_k(x) = g^N(x)$$

is a polynomial equation that is true in R and in its subring $\mathbb{C}[x]$. Since f_1, \dots, f_k are in I , this equation shows that g^N is in I . □

2.4.9. Corollary. Let $\mathbb{C}[x]$ denote the polynomial ring $\mathbb{C}[x_1, \dots, x_n]$.

(i) Let P be a prime ideal of $\mathbb{C}[x]$, and let $V = V(P)$ be the variety of zeros of P in \mathbb{A}^n . If a polynomial g vanishes at every point of V , then g is an element of P .

(ii) Let f be an irreducible polynomial in $\mathbb{C}[x]$. If a polynomial g vanishes at every point of $V(f)$, then f divides g .

(iii) Let I and J be ideals of $\mathbb{C}[x]$. Then $V(I) \supset V(J)$ if and only if $\text{rad } I \subset \text{rad } J$, and $V(I) > V(J)$ if and only if $\text{rad } I > \text{rad } J$. (See (2.2.2).) □

2.4.10. Examples.

(i) Let I be the ideal generated by y^5 and $y^2 - x^3$ in the polynomial algebra $\mathbb{C}[x, y]$ in two variables. The origin $y = x = 0$ is the only common zero of these polynomials in the affine plane, and the polynomial x also vanishes at the origin. The Strong Nullstellensatz predicts that I contains a power of x . This is verified by the following equation:

$$yy^5 - (y^4 + y^2x^3 + x^6)(y^2 - x^3) = x^9$$

(ii) We may regard pairs A, B of $n \times n$ matrices as points of an affine space \mathbb{A}^{2n^2} with coordinates a_{ij}, b_{ij} , $1 \leq i, j \leq n$. The pairs of commuting matrices ($AB = BA$) form a closed subset of \mathbb{A}^{2n^2} , the locus of common zeros of the n^2 polynomials c_{ij} that compute the entries of the matrix $AB - BA$:

$$(2.4.11) \quad c_{ij}(a, b) = \sum_{\nu} a_{i\nu}b_{\nu j} - b_{i\nu}a_{\nu j} \quad \text{comm-mateq}$$

Let I denote the ideal of the polynomial algebra $\mathbb{C}[a, b]$ generated by the polynomials c_{ij} . Then $V(I)$ is the set of pairs of commuting complex matrices. The Strong Nullstellensatz asserts that if a polynomial $g(a, b)$ vanishes on every pair of commuting matrices, some power of g is in I . Is g itself in I ? It is a famous conjecture that I is a prime ideal. If so, g would be in I . Proving the conjecture would establish your reputation as a mathematician, but I don't recommend spending very much time on it right now. □

2.5 The Spectrum

spectru-
malg

The Nullstellensatz allows us to associate a set of points to a finite-type domain A without reference to a presentation. We can do this because the maximal ideals of A and the homomorphisms $A \rightarrow \mathbb{C}$ don't depend on the presentation. When a finite-type domain A is presented as a quotient $\mathbb{C}[x]/P$ of a polynomial ring, where P is a prime ideal, A becomes the coordinate algebra of the variety $V(P)$ in affine space. Then the points of $V(P)$ correspond to maximal ideals of A and also to homomorphisms $A \rightarrow \mathbb{C}$.

When a finite-type domain A is given without a presentation, we replace the variety $V(P)$ by an abstract set of points, the *spectrum* of A , that we denote by $\text{Spec } A$ and call an *affine variety*. We put one point p into the spectrum for every maximal ideal of A , and then we turn around and denote the maximal ideal that corresponds to a point p by \bar{m}_p . The Nullstellensatz tells us that p also corresponds to a homomorphism $A \rightarrow \mathbb{C}$ whose kernel is \bar{m}_p . We denote that homomorphism by $\bar{\pi}_p$. In analogy with (2.2.21), the domain A is called the *coordinate algebra* of the affine variety $\text{Spec } A$. To work with $\text{Spec } A$, we may interpret its points as maximal ideals or as homomorphisms to \mathbb{C} , whichever is convenient.

When defined in this way, the variety $\text{Spec } A$ isn't embedded into affine space, but because A is a finite-type algebra, it can be presented as a quotient $\mathbb{C}[x]/P$. When this is done, points of $\text{Spec } A$ correspond to points of the subset $V(P)$ in \mathbb{A}^n .

Even when the coordinate ring A of an affine variety is presented as $\mathbb{C}[x]/P$, we may denote the variety by $\text{Spec } A$ rather than by $V(P)$.

Let $X = \text{Spec } A$. The elements of A define (complex-valued) functions on X as follows: A point p of X corresponds to a homomorphism $A \xrightarrow{\bar{\pi}_p} \mathbb{C}$. If α is an element of A , the *value* of the function α at p is defined to be $\bar{\pi}_p(\alpha)$:

defalphap

$$(2.5.1) \quad \alpha(p) \stackrel{\text{def}}{=} \bar{\pi}_p(\alpha)$$

The kernel \bar{m}_p of $\bar{\pi}_p$ is the set of elements α of the coordinate algebra A such that $\alpha(p) = 0$:

$$\bar{m}_p = \{\alpha \in A \mid \alpha(p) = 0\}$$

The functions defined by the elements of A are called *regular functions* on X . (See Proposition 2.7.2 below.)

regfndetelt

2.5.2. Lemma. *The regular functions determined by distinct elements α and β of A are distinct.*

proof. We replace α by $\alpha - \beta$. Then what is to be shown is that, if the function determined by an element α is the zero function, then α is the zero element.

We present A as $\mathbb{C}[x]/P$, $x = x_1, \dots, x_n$, where P is a prime ideal. Then X is the locus of zeros of P in \mathbb{A}^n , and Corollary 2.4.9 (iii) tells us that P is the ideal of *all* elements that are zero on X .

Let $g(x)$ be a polynomial that represents α . If p is a point of X at which α is zero, then $g(p) = 0$. So if α is the zero function, then g is in P , and therefore $\alpha = 0$. \square

For example, the spectrum $\text{Spec } \mathbb{C}[x_1, \dots, x_n]$ of the polynomial algebra is the affine space \mathbb{A}^n . The homomorphism $\pi_p : \mathbb{C}[x] \rightarrow \mathbb{C}$ that corresponds to a point $p = (a_1, \dots, a_n)$ of \mathbb{A}^n is evaluation at p . So $\pi_p(g) = g(a_1, \dots, a_n) = g(p)$. The function defined by a polynomial $g(x)$ is simply the polynomial function.

Note. In modern terminology, the word "spectrum" is usually used to denote the set of prime ideals of a ring. This becomes important when one studies rings that aren't finite-type algebras. When working with finite-type algebras, there are enough maximal ideals. The other prime ideals aren't needed, so we have eliminated them.

gpequal-
salphap

2.5.3. Lemma. *Let A be a quotient $\mathbb{C}[x]/P$ of the polynomial ring $\mathbb{C}[x_1, \dots, x_n]$ modulo a prime ideal P , so that $\text{Spec } A$ becomes the closed subset $V(P)$ of \mathbb{A}^n . Then a point p of $\text{Spec } A$ becomes a point of \mathbb{A}^n : $p = (a_1, \dots, a_n)$. When an element α of A is represented by a polynomial $g(x)$, the value of α at p is $\alpha(p) = g(p) = g(a_1, \dots, a_n)$.*

proof. The point p of $\text{Spec } A$ gives us a diagram (2.4.5), with $\pi = \pi_p$ and $\bar{\pi} = \bar{\pi}_p$, and where τ is the canonical map $\mathbb{C}[x] \rightarrow A$. Then $\alpha = \tau(g)$, and

redefinefn

$$(2.5.4) \quad g(p) \stackrel{\text{defn}}{=} \pi_p(g) = \bar{\pi}_p \tau(g) = \bar{\pi}_p(\alpha) \stackrel{\text{defn}}{=} \alpha(p). \quad \square$$

Thus the value $\alpha(p)$ at a point p of $\text{Spec } A$ can be obtained by evaluating a suitable polynomial g , though that polynomial isn't unique. The polynomial that represents a regular function α won't be unique unless P is the zero ideal.

(2.5.5) the Zariski topology on an affine variety

ztoponvar

Let $X = \text{Spec } A$ be an affine variety with coordinate algebra A . An ideal \bar{J} of A defines a locus in X , a closed subset, that we denote by $V_X(\bar{J})$. The points of $V_X(\bar{J})$ are the points of X at which all elements of \bar{J} vanish. This is analogous to (2.4.2):

$$(2.5.6) \quad V_X(\bar{J}) = \{p \in \text{Spec } A \mid \bar{J} \subset \bar{m}_p\}$$

locusin-spec
zerolocus-inX

2.5.7. Lemma. *Let A be a finite-type domain, presented as $A = \mathbb{C}[x]/P \approx A$. An ideal \bar{J} of A corresponds to an ideal J of $\mathbb{C}[x]$ that contains P , and if $V_{\mathbb{A}^n}(J)$ denotes the zero locus of J in \mathbb{A}^n , then $V_X(\bar{J}) = V_{\mathbb{A}^n}(J)$. \square*

The properties of closed sets in affine space that are given in Lemmas 2.2.3 and 2.2.5 are true for closed subsets of an affine variety. In particular, $V_X(\bar{J}) = V_X(\text{rad } \bar{J})$, and $V_X(\bar{I}\bar{J}) = V_X(\bar{I} \cap \bar{J}) = V_X(\bar{I}) \cup V_X(\bar{J})$.

2.5.8. Proposition. *Let \bar{J} be an ideal of a finite-type domain A , and let $X = \text{Spec } A$. The zero set $V_X(\bar{J})$ is empty if and only if \bar{J} is the unit ideal of A . If X is empty, then A is the zero ring.*

empty

proof. The only ideal that isn't contained in a maximal ideal is the unit ideal. \square

2.5.9. Note. In this section, we have put bars on the symbols \bar{m} and $\bar{\pi}$ here in order to distinguish maximal ideals of A from maximal ideals of $\mathbb{C}[x]$ and homomorphisms $A \rightarrow \mathbb{C}$ from homomorphisms $\mathbb{C}[x_1, \dots, x_n] \rightarrow \mathbb{C}$. In the future, we will put bars over the letters only when there is a danger of confusion. Most of the time, we will denote an ideal of A by an ordinary letter such as J . \square

nobar

2.5.10. Lemma. *An ideal I of a noetherian ring R contains a power of its radical.*

radpower

proof. Since R is noetherian, the ideal $\text{rad } I$ is generated by a finite set of elements $\alpha = \{\alpha_1, \dots, \alpha_k\}$, and for large r , α_i^r is in I . We can use the same large integer r for every i . A monomial $\beta = \alpha_1^{e_1} \cdots \alpha_k^{e_k}$ of sufficiently large degree n in α will be divisible α_i^r for at least one i , and therefore it will be in I . The monomials of degree n generate $(\text{rad } I)^n$, so $(\text{rad } I)^n \subset I$. And as has been remarked, $I \subset \text{rad } I$. \square

The next corollary follows from the case of polynomial ring, which is Corollary 2.4.9 (iii), and from Lemma 2.5.7.

2.5.11. Corollary. *Let I and J be ideals of a finite-type domain A , and let $X = \text{Spec } A$. Then $V_X(I) \supset V_X(J)$ if and only if $\text{rad } I \subset \text{rad } J$. \square*

subsof-specA

The next proposition includes Proposition 2.2.20 as a special case.

2.5.12. Proposition. *Let $X = \text{Spec } A$, where A is a finite-type domain. The closed subset $V_X(P)$ defined by a radical ideal P is irreducible if and only if P is a prime ideal.*

proofirred-prime

proof. Let P be a radical ideal of A , and let $Y = V_X(P)$. Let C and D be closed subsets of X such that $Y = C \cup D$. Say $C = V_X(I)$, $D = V_X(J)$. We may suppose that I and J are radical ideals. Then the inclusion $C \subset Y$ implies that $I \supset P$. Similarly, $J \supset P$. Because $Y = C \cup D$, we also have $Y = V_X(I \cap J) = V_X(IJ)$. So $IJ \subset P$ (Corollary 2.5.11). If P is a prime ideal, then $I = P$ or $J = P$, and therefore $C = Y$ or $D = Y$ (Lemma 2.1.3 iii'), and Y is irreducible. Conversely, if P isn't a prime ideal, there are ideals I, J strictly larger than the radical ideal P , such that $IJ \subset P$ (2.1.3). Then Y will be the union of the two proper closed subsets $V_X(I)$ and $V_X(J)$, so Y isn't irreducible (2.5.11). \square

(2.5.13) the nilradical

thenilradical

The *nilradical* of a ring is the set of its nilpotent elements. It is the radical of the zero ideal. The nilradical of a domain is the zero ideal. If a ring R is noetherian, its nilradical will be *nilpotent*: some power of it will be the zero ideal (Lemma 2.5.10).

intersect-
primes

2.5.14. Proposition. *The nilradical of a noetherian ring R is the intersection of the prime ideals of R .*

proof. Let x be an element of the nilradical N . Some power of x is zero. Since the zero element is in every prime ideal, x is in every prime ideal. Therefore N is contained in every prime ideal. Conversely, let x be an element not in N , i.e., not nilpotent. We show that there is a prime ideal that doesn't contain x . Let \mathcal{S} be the set of ideals that don't contain any power of x . The zero ideal is one such ideal, so \mathcal{S} isn't empty. Since R is noetherian, \mathcal{S} contains a maximal member P (2.1.12). We show that P is a prime ideal by showing that, if two ideals A and B are strictly larger than P , their product AB isn't contained in P . Since P is a maximal member of \mathcal{S} , A and B aren't in \mathcal{S} . They contain powers of x , say $x^k \in A$ and $x^\ell \in B$. Then $x^{k+\ell}$ is in AB but not in P . Therefore $AB \not\subset P$. \square

Note. The conclusion of this proposition is true whether or not the ring R is noetherian.

2.5.15. Corollary.

strongnullA

(i) *Let A be a finite-type algebra. An element that is in every maximal ideal of A is nilpotent.*

(ii) *Let A be a finite-type domain. The intersection of the maximal ideals of A is the zero ideal.*

proof. (i) Say that A is presented as $\mathbb{C}[x_1, \dots, x_n]/I$. Let α be an element of A that is in every maximal ideal, and let $g(x)$ be a polynomial whose residue in A is α . Then α is in every maximal ideal of A if and only if $g = 0$ at all points of the variety $V_{\mathbb{A}}(I)$ in \mathbb{A}^n . If so, the Strong Nullstellensatz asserts that some power g^N is in I . Then $\alpha^N = 0$. \square

findetermi-
neselt

2.5.16. Corollary. *An element α of a finite-type domain A is determined by the function that it defines on $X = \text{Spec } A$.*

proof. It is enough to show that an element α that defines the zero function is the zero element. Such an element is in every maximal ideal (2.5.8), so α is nilpotent, and since A is a domain, $\alpha = 0$. \square

2.6 Localization

boldloc

Let s be a nonzero element of a domain A . The ring $A[s^{-1}]$, obtained by adjoining an inverse of s to A is called a *localization* of A . It is isomorphic to the quotient $A[z]/(sz - 1)$ of the polynomial ring $A[z]$ by the principal ideal generated by $sz - 1$. We will often denote this localization by A_s . If A is a finite-type domain, so is A_s . In that case, if X denotes the variety $= \text{Spec } A$, X_s will denote the variety $\text{Spec } A_s$, and X_s will be called a *localization* of X too.

topology-
onlocal-
ization

2.6.1. Proposition. (i) *With terminology as above, points of the localization $X_s = \text{Spec } A_s$ correspond bijectively to the open subset of X of points at which the function defined by s is nonzero.*

(ii) *When we identify a localization X_s with a subset of X , the Zariski topology on X_s is the induced topology from X . So X_s is an open subspace of X .*

proof. (i) Let p be a point of X , let $A \xrightarrow{\pi_p} \mathbb{C}$ be the corresponding homomorphism. If s isn't zero at p , i.e., $s(p) = c \neq 0$, then π_p extends uniquely to a homomorphism $A_s \rightarrow \mathbb{C}$ that sends s^{-1} to c^{-1} . This gives us a unique point of X_s whose image in X is p . If $c = 0$, then π_p doesn't extend to A_s .

(ii) Let C be a closed subset of X , say the zero set of a set of elements a_1, \dots, a_k of A . Then $C \cap X_s$ is the zero set in X_s of those same elements, so it is closed in X_s . Conversely, let D be a closed subset of X_s , say the zero set in X_s of some elements β_1, \dots, β_k , where $\beta_i = b_i s^{-n_i}$ with b_i in A . Since s^{-1} doesn't vanish on X_s , the elements b_i and β_i have the same zeros in X_s . If we let C be the zero set of b_1, \dots, b_k in X , we will have $C \cap X_s = D$. \square

We usually identify X_s with the corresponding open subset of X . Then the effect of adjoining the inverse is to throw out the points of X at which s vanishes. For example, the spectrum of the Laurent polynomial ring $\mathbb{C}[t, t^{-1}]$ becomes the complement of the origin in the affine line $\mathbb{A}^1 = \text{Spec } \mathbb{C}[t]$.

This illustrates one benefit of working with an affine variety without a fixing an embedding into affine space. If X is embedded into \mathbb{A}^n , the localization X_s wants to be in \mathbb{A}^{n+1} .

As is true for many open sets, the complement X' of the origin in the affine plane $\text{Spec } \mathbb{C}[x_1, x_2]$ isn't a localization. Every polynomial that vanishes at the origin vanishes on an affine curve, which has points distinct

from the origin. So the inverse of such a polynomial doesn't define a function on X' . This is rather obvious, but in other situations, it is often hard to tell whether or not a given open set is a localization.

Localizations are important for two reasons:

- The relation between an algebra A and a localization A_s is easy to understand, and
- The localizations X_s of an affine variety X form a basis for the Zariski topology on X .

A *basis* for the topology on a topological space X is a family \mathcal{B} of open sets such that every open set is a union of open sets that are members of \mathcal{B} .

To verify that the localizations X_s form a basis for the topology on an affine variety X , we must show that an open subset U of $X = \text{Spec } A$ can be covered by sets of the form X_s . The zero set $V_X(s)$ of s is the complement of X_s in X , the set $X - X_s$. Let C be the closed complement $X - U$ of U in X . Since C is closed, it is the set of common zeros of some elements s_1, \dots, s_k of A . Then C is the intersection $\bigcap V_X(s_i)$ of zero sets, and U is the union of those sets X_{s_i} . \square

2.6.2. Lemma. *Let U and V be affine open subsets of an affine variety X .*

locloc

- (i) *If V is a localization of U and U is a localization of X , then V is a localization of X .*
- (ii) *If $V \subset U$ and V is a localization of X , then V is a localization of U .*
- (iii) *Let p be a point of $U \cap V$. There is an open set Z containing p that is a localization of U and also a localization of V .*

proof. (i) Say that $X = \text{Spec } A$, $U = X_s = \text{Spec } A_s$, and $V = U_t = \text{Spec}(A_s)_t$. Then t is an element of A_s , say $t = rs^{-k}$ with r in A . The localizations $(A_s)_t$ and $(A_s)_r$ are equal, and $(A_s)_r = A_{sr}$. So $V = X_{sr}$.

(ii) Say that $X = \text{Spec } A$, $U = \text{Spec } B$, and $V = \text{Spec } A_t$, where t is a nonzero element of A . A regular function on X restricts to a regular on U , and a regular function on U restricts to a regular function on V . These restrictions define homomorphisms $A \rightarrow B \rightarrow A_t$, which are injective because $A \subset A_t$. Since t is in B , $B_t \subset A_t$, and therefore $B = A_t$.

(iii) Since localizations form a basis for the topology, $U \cap V$ contains a localization X_s of X that contains p . By (ii), X_s is also a localization of U and a localization of V . \square

(2.6.3) extension and contraction of ideals

extcontr

Let $A \subset B$ be the inclusion of a ring A as a subring of a ring B . The *extension* of an ideal I of A is the ideal IB of B generated by I . Its elements are finite sums $\sum_i z_i b_i$ with z_i in I and b_i in B . The *contraction* of an ideal J of B is the intersection $J \cap A$, which is an ideal of A .

If A_s is a localization of A and I is an ideal of A , the elements of the extended ideal IA_s are fractions of the form zs^{-k} , with z in I . We denote this extended ideal by I_s .

2.6.4. Lemma.

extcontr-prop

- (i) *Let A_s be a localization of a domain A , let J be an ideal of A_s and let $I = J \cap A$. Then $J = I_s$. Every ideal of A_s is the extension of an ideal of A .*
- (ii) *Let P be a prime ideal of A . If s is an element of A that isn't in P , the extended ideal P_s is a prime ideal of A_s . If s is in P , the extended ideal P_s is the unit ideal.* \square

(2.6.5) localizing a module

locmod

Let A be a domain, and let M be an A -module. A *torsion element* of M is an element that is annihilated by some nonzero element s of A : $sm = 0$. A nonzero element m such that $sm = 0$ is called an *s-torsion* element.

The set of all torsion elements of M is its *torsion submodule*, and a module whose torsion submodule is zero is *torsion-free*.

Let s be a nonzero element of a domain A . The *localization* M_s of an A -module M is defined in the natural way, as the A_s -module whose elements are equivalence classes of fractions $m/s^r = ms^{-r}$, with m in M and $r \geq 0$. An alternate notation for the localization M_s is $M[s^{-1}]$. The only complication comes from the fact that there may be s -torsion elements in M . If $ms = 0$, then m must map to zero in M_s , because in M_s , we will have $mss^{-1} = m$.

To define M_s , it suffices to modify the equivalence relation. Two fractions $m_1s^{-r_1}$ and $m_2s^{-r_2}$ are defined to be equivalent $m_1s^{r_2+n} = m_2s^{r_1+n}$ when n is sufficiently large. This takes care of torsion, and M_s becomes an A_s -module. There will be a homomorphism $M \rightarrow M_s$ that sends an element m to the fraction $m/1$.

This is also how one localizes a ring that isn't a domain.

multsys (2.6.6) **multiplicative systems**

To work with the inverses of finitely many nonzero elements, one may simply adjoin the inverse of their product. For working with an infinite set of inverses, the concept of a multiplicative system is useful.

A *multiplicative system* S in a domain A is a subset that consists of nonzero elements, is closed under multiplication, and contains 1. If S is a multiplicative system, the ring of *S -fractions* AS^{-1} is the ring obtained by adjoining inverses of all elements of S . Its elements are equivalence classes of fractions as^{-1} with a in A and s in S , the equivalence relation and the laws of composition being the usual ones for fractions. The ring AS^{-1} will be called a *localization* too. For emphasis, the ring obtained by inverting a single element s may be called a *simple localization*.

inverseex- 2.6.7. **Examples.** (i) The set consisting of the powers of a nonzero element s of a domain A is a multiplicative system. Its ring of fractions is the simple localization $A_s = A[s^{-1}]$.

(ii) The set S of all nonzero elements of a domain A is a multiplicative system. Its ring of fractions is the field of fractions of A .

(iii) An ideal P of a domain A is a prime ideal if and only if its complement, the set of elements of A **not** in P , is a multiplicative system. □

extendide- 2.6.8. **Proposition.** Let S be a multiplicative system in a domain A , and let A' be the localization AS^{-1} .

(i) Let I be an ideal of A . The *extended ideal* IA' (2.6.3) is the set IS^{-1} whose elements are classes of fractions xs^{-1} , with x in I and s in S . The extended ideal is the unit ideal if and only if I contains an element of S .

(ii) Let J be an ideal of the localization A' and let I denote its contraction $J \cap A$. The extended ideal IA' is equal to J : $J = (J \cap A)A'$.

(iii) If Q is a prime ideal of A and if $Q \cap S$ is empty, the extended ideal $Q' = QA'$ is a prime ideal of A' , and the contraction $Q' \cap A$ is equal to Q . If $Q \cap S$ isn't empty, the extended ideal is the unit ideal. Thus prime ideals of AS^{-1} correspond bijectively to prime ideals of A that don't meet S . □

locfntype 2.6.9. **Corollary.** Every localization AS^{-1} of a noetherian domain A is noetherian. □

import- (2.6.10) **a general principle**

An important, though elementary, principle for working with fractions is that any finite sequence of computations in a localization AS^{-1} will involve only finitely many denominators, and can therefore be done in a simple localization A_s , where s is a common denominator for the fractions that occur.

Let S be a multiplicative system in a domain A . The *localization* MS^{-1} of an A -module M is defined in a way analogous to the one used for simple localizations, as the AS^{-1} -module whose elements are equivalence classes of fractions ms^{-1} with m in M and s in S . To take care of torsion, two fractions $m_1s_1^{-1}$ and $m_2s_2^{-1}$ are defined to be equivalent if there is an element $\tilde{s} \in S$ such that $m_1s_2\tilde{s} = m_2s_1\tilde{s}$. Then $m_1s_1^{-1} = 0$ if and only if $m\tilde{s} = 0$ for some \tilde{s} in S . As with simple localizations, there will be a homomorphism $M \rightarrow MS^{-1}$ that sends an element m to the fraction $m/1$.

2.6.11. Proposition. Let S be a multiplicative system in a domain A .

lolexact

(i) Localization is an exact functor: A homomorphism $M \xrightarrow{\varphi} N$ of A -modules induces a homomorphism $MS^{-1} \xrightarrow{\varphi'} NS^{-1}$ of AS^{-1} -modules, and if $M \xrightarrow{\varphi} N \xrightarrow{\psi} P$ is an exact sequence of A -modules, the localized sequence $MS^{-1} \xrightarrow{\varphi'} NS^{-1} \xrightarrow{\psi'} PS^{-1}$ is exact.

(ii) Let M be an A -module. and let N be an AS^{-1} -module. Homomorphisms of AS^{-1} -modules $MS^{-1} \rightarrow N$ correspond bijectively to homomorphisms of A -modules $M \rightarrow N$, when N is made into an A -module by restriction of scalars.

(iii) If multiplication by s is an injective map $M \rightarrow M$ for every s in S , then $M \subset MS^{-1}$. If multiplication by every s is a bijective map $M \rightarrow M$, then $M \approx MS^{-1}$. \square

2.7 Morphisms of Affine Varieties

Morphisms are the allowed maps between varieties. Morphisms between affine varieties are defined below. They correspond to algebra homomorphisms in the opposite direction between their coordinate algebras.

morphism

Morphisms of projective varieties require more thought. They will be defined in the next chapter.

(2.7.1) regular functions

regfnone

The function field K of an affine variety $X = \text{Spec } A$ is the field of fractions of A . A rational function on X is a nonzero element of the function field K .

As we have seen, in (2.5.1), elements of the coordinate algebra A define functions on X . The value of the function α at a point p is $\alpha(p) = \pi_p(\alpha)$, where π_p is the homomorphism $A \rightarrow \mathbb{C}$ that corresponds to p . A rational function $f = a/s$ with a and s in A is an element of A_s , and it defines a function on the open subset X_s . A rational function f is regular at a point p of X if it can be written as a fraction a/s such that $s(p) \neq 0$. A rational function is regular on X if it is regular at every point of X . The zero element is called regular too.

2.7.2. Proposition. The regular functions on an affine variety $X = \text{Spec } A$ are the elements of the coordinate algebra A .

deloca

proof. Let f be a rational function that is regular on X . So for every point p of X , there is a localization $X_s = \text{Spec } A_s$ that contains p , such that f is an element of A_s . Because X is quasicompact, a finite set of these localizations, say X_{s_1}, \dots, X_{s_k} , will cover X . Then s_1, \dots, s_k have no common zeros on X , so they generate the unit ideal of A (2.5.8). Since f is in A_{s_i} , we can write $f = s_i^{-n} b_i$, or $s_i^n f = b_i$, with b_i in A , and we can use the same exponent n for each i . Since the elements s_i generate the unit ideal of A , so do the powers s_i^n . So we can write $\sum s_i^n c_i = 1$, with c_i in A . Then $f = \sum s_i^n c_i f = \sum c_i b_i$ is an element of A . \square

(2.7.3) morphisms

morphtwo

Let $X = \text{Spec } A$ and $Y = \text{Spec } B$ be affine varieties, and let $A \xrightarrow{\varphi} B$ be an algebra homomorphism. A point q of Y corresponds to an algebra homomorphism $B \xrightarrow{\pi_q} \mathbb{C}$. When we compose π_q with φ , we obtain a homomorphism $A \xrightarrow{\pi_q \varphi} \mathbb{C}$. By definition, the points of $\text{Spec } A$ correspond to homomorphisms $A \xrightarrow{\pi_p} \mathbb{C}$. So there is a unique point p of $X = \text{Spec } A$ such that $\pi_p = \pi_q \varphi$:

2.7.4. Definition. Let $X = \text{Spec } A$ and $Y = \text{Spec } B$. A morphism $Y \xrightarrow{u} X$ is a map that can be defined by an algebra homomorphism $A \xrightarrow{\varphi} B$, as follows: If q is a point of Y , then uq is the point p of X such that $\pi_p = \pi_q \varphi$.

defmorph

$$(2.7.5) \quad \begin{array}{ccc} A & \xrightarrow{\varphi} & B \\ \pi_p \downarrow & & \downarrow \pi_q \\ \mathbb{C} & \xlongequal{\quad} & \mathbb{C} \end{array} \quad \begin{array}{ccc} X & \xleftarrow{u} & Y \\ \uparrow & & \uparrow \\ p & \xleftarrow{\quad} & q \end{array}$$

piqphi

Let α be an element of A , let $\beta = \varphi(\alpha)$, and let uq is the image in X of a point q of Y , then $\beta(q) = \alpha(uq)$:

bisphia (2.7.6)
$$\beta(q) = \pi_q(\beta) = \pi_q(\varphi\alpha) = \pi_p(\alpha) = \alpha(p)$$

A morphism $Y \xrightarrow{u} X$ is an *isomorphism* if and only if there is an inverse morphism. This will be true if and only if $A \xrightarrow{\varphi} B$ is an isomorphism of algebras. \square

The next formula sums up the relation between a homomorphism $A \xrightarrow{\varphi} B$ and the associated morphism $Y \xrightarrow{u} X$. If q is a point of Y and α is an element of A , then

auqphiaq (2.7.7)
$$\alpha[u(q)] = [\varphi\alpha](q)$$

Thus the homomorphism φ is determined by the map u , and vice-versa. But just as most maps $A \rightarrow B$ aren't homomorphisms, most maps $Y \rightarrow X$ aren't morphisms.

The description of a morphism can be confusing because the direction of the arrow is reversed. It will become clearer as we expand the discussion, though it will always be somewhat confusing.

Morphisms to the affine line.

A morphism $Y \xrightarrow{u} \mathbb{A}^1$ from a variety $Y = \text{Spec } B$ to the affine line $\text{Spec } \mathbb{C}[x]$ is defined by an algebra homomorphism $\mathbb{C}[x] \xrightarrow{\varphi} B$, and such a homomorphism substitutes an element β of B for x . The corresponding morphism u sends a point q of Y to the point of the x -line at which $x = \beta(q)$.

For example, let Y be the space of 2×2 matrices, so that $B = \mathbb{C}[y_{ij}]$, $1 \leq i, j \leq 2$, and let \mathbb{A}^1 be the affine line $\text{Spec } \mathbb{C}[x]$. The determinant defines a morphism $Y \rightarrow \mathbb{A}^1$. The corresponding algebra homomorphism $\mathbb{C}[x] \xrightarrow{\varphi} \mathbb{C}[y_{ij}]$ substitutes $y_{11}y_{22} - y_{12}y_{21}$ for x . It sends a polynomial $f(x)$ to $f(y_{11}y_{22} - y_{12}y_{21})$.

In the other direction, a morphism from \mathbb{A}^1 to a variety Y may be called a (complex) polynomial path in Y . For example, if Y is the space of matrices, a morphism $\mathbb{A}^1 \rightarrow Y$ corresponds to a homomorphism $\mathbb{C}[y_{ij}] \rightarrow \mathbb{C}[x]$, and such a homomorphism substitutes a polynomial in x for each variable y_{ij} .

Morphisms to affine space.

A morphism from an affine variety $Y = \text{Spec } B$ to affine space \mathbb{A}^n will be defined by a homomorphism $\mathbb{C}[x_1, \dots, x_n] \xrightarrow{\Phi} B$, which substitutes elements β_i of B for x_i : $\Phi(f(x)) = f(\beta)$. (We use an upper case Φ in order to keep φ in reserve.) The corresponding morphism $Y \xrightarrow{u} \mathbb{A}^n$ sends a point q of Y to the point $(\beta_1(q), \dots, \beta_n(q))$ of \mathbb{A}^n .

Morphisms to affine varieties.

Let $X = \text{Spec } A$ and $Y = \text{Spec } B$ be affine varieties. Say that we have chosen a presentation $A = \mathbb{C}[x_1, \dots, x_m]/(f_1, \dots, f_k)$ of A , so that X becomes the closed subvariety $V(f)$ of affine space \mathbb{A}^m . There is no need to choose a presentation of B . A natural way to define a morphism from a variety Y to X is as a morphism $Y \xrightarrow{u} \mathbb{A}^m$ to affine space, whose image is contained in X . We check that this agrees with Definition 2.7.4:

As above, a morphism $Y \xrightarrow{u} \mathbb{A}^m$ corresponds to a homomorphism $\mathbb{C}[x_1, \dots, x_m] \xrightarrow{\Phi} B$. It will be determined by the set $(\beta_1, \dots, \beta_m)$ of elements of B such that $\beta_i = \Phi(x_i)$. Since X is the locus of zeros of the polynomials f , the image of Y will be contained in X if and only if $f_i(\beta_1(q), \dots, \beta_m(q)) = 0$ for every point q of Y and every i , i.e., if and only if $f_i(\beta)$ is in every maximal ideal of B , in which case $f_i(\beta) = 0$ (2.5.15)(i). Another way to say this is:

The image of Y is contained in X if and only if $\beta = (\beta_1, \dots, \beta_m)$ solves the equations $f(x) = 0$. And, if β is a solution, the map Φ defines a map $A \xrightarrow{\varphi} B$.

$$\begin{array}{ccc} \mathbb{C}[x] & \xrightarrow{\Phi} & B \\ \downarrow & & \parallel \\ A & \xrightarrow{\varphi} & B \end{array}$$

There is an elementary, but important, principle at work here:

• Homomorphisms from an algebra $A = \mathbb{C}[x]/(f)$ to an algebra B correspond to solutions of the equations $f = 0$ in B .

2.7.8. Example. Let $B = \mathbb{C}[x]$, and let A be the coordinate algebra $\mathbb{C}[u, v]/(v^2 - u^3)$ of a cusp curve. A homomorphism $A \rightarrow B$ is determined by a solution of the equation $v^2 = u^3$ in $\mathbb{C}[x]$. For example, $u = x^3$ and $v = x^3$ is a solution. Every solution will have the form $u = f^3, v = f^2$ with f in $\mathbb{C}[x]$. \square

2.7.9. Corollary. Let $X = \text{Spec } A$ and let $Y = \text{Spec } B$ be affine varieties. Suppose that A is presented as the quotient $\mathbb{C}[x_1, \dots, x_m]/(f_1, \dots, f_k)$ of a polynomial ring. There are bijective correspondences between the following sets:

- algebra homomorphisms $A \rightarrow B$, or morphisms $Y \rightarrow X$,
- morphisms $Y \rightarrow \mathbb{A}^n$ whose images are contained in X ,
- solutions of the equations $f_i(x) = 0$ in B , \square

The second and third sets refer to an embedding of the variety X into affine space, but the first one does not. It shows that a morphism depends only on the varieties X and Y , not on an embedding of X ,

The geometry of a morphism will be described more completely in Chapters 4 and 5. We note a few more facts about them here.

2.7.10. Proposition. Let $X \xleftarrow{u} Y$ be the morphism of affine varieties that corresponds to a homomorphism of coordinate algebras $A \xrightarrow{\varphi} B$.

(i) Let $Y \xleftarrow{v} Z$ be another morphism, corresponding to another homomorphism $B \xrightarrow{\psi} R$ of finite-type domains. The composition $Z \xrightarrow{uv} X$ is the morphism that corresponds to the composed homomorphism $A \xrightarrow{\psi\varphi} R$.

(ii) Suppose that $B = A/P$, where P is a prime ideal of A , and that φ is the canonical homomorphism $A \rightarrow A/P$. Then u is the inclusion of the closed subvariety $Y = V_X(P)$ into X .

(iii) φ is surjective if and only if u maps Y isomorphically to a closed subvariety of X . \square

It is useful to rephrase the definition of the morphism $Y \xrightarrow{u} X$ that corresponds to a homomorphism $A \xrightarrow{\varphi} B$ in terms of maximal ideals. Let \mathfrak{m}_q be the maximal ideal of B at a point q of Y . The inverse image of \mathfrak{m}_q in A is the kernel of the composed homomorphism $A \xrightarrow{\varphi} B \xrightarrow{\pi_q} \mathbb{C}$, so it is a maximal ideal of A : $\varphi^{-1}\mathfrak{m}_q = \mathfrak{m}_p$ for some point p of X . That point is the image of q : $p = uq$.

In the other direction, let \mathfrak{m}_p be the maximal ideal at a point p of X , and let J be the ideal generated by the image of \mathfrak{m}_p in B . This ideal is called the *extension* of \mathfrak{m}_p to B . Its elements are finite sums $\sum \varphi(z_i)b_i$ with z_i in \mathfrak{m}_p and b_i in B . If q is a point of Y , then $uq = p$ if and only if $\mathfrak{m}_p = \varphi^{-1}\mathfrak{m}_q$, and this will be true if and only if J is contained in \mathfrak{m}_q .

Recall that, if $Y \xrightarrow{u} X$ is a map of sets, the *fibre* of Y over a point p of X is the set of points q of Y that map to p .

2.7.11. Corollary. Let $X = \text{Spec } A$ and $Y = \text{Spec } B$, and let $Y \xrightarrow{u} X$ be the morphism corresponding to a homomorphism $A \xrightarrow{\varphi} B$. Let \mathfrak{m}_p be the maximal ideal at a point p of X , and let $J = \mathfrak{m}_p B$ be the extended ideal.

- (i) The fibre of Y over p is the set $V_Y(J)$ of points q such that $J \subset \mathfrak{m}_q$.
- (ii) The fibre of Y over p is empty if and only if J is the unit ideal of B . \square

2.7.12. Example. (blowing up the plane)

Let W and X be planes with coordinates (x, w) and (x, y) , respectively. The blowup map $W \xrightarrow{\pi} X$ was defined before (1.8.6). It is defined by the substitution $\pi(x, w) = (x, xw)$, which corresponds to the algebra homomorphism $\mathbb{C}[x, y] \xrightarrow{\varphi} \mathbb{C}[x, w]$ defined by $\varphi(x) = x, \varphi(y) = xw$. To be specific, the image of the point $q : (x, w) = (a, c)$ of W in X is $p : (x, y) = (a, ac)$.

As was explained in (1.8.6), the morphism is bijective at points (x, y) at which $x \neq 0$. The fibre of Z over a point of Y of the form $(0, y)$ is empty unless $y = 0$, and the fibre over the origin $(0, 0)$ in Y is the w -axis $\{(0, z)\}$ in the plane W . \square

figure

mcont **2.7.13. Proposition.** A morphism $Y \xrightarrow{u} X$ of affine varieties is a continuous map in the Zariski topology and also in the classical topology.

proof. The Zariski topology: Let $X = \text{Spec } A$ and $Y = \text{Spec } B$, so that u corresponds to an algebra homomorphism $A \xrightarrow{\varphi} B$. A closed subset C of X will be the zero locus of a set $\alpha = \{\alpha_1, \dots, \alpha_k\}$ of elements of A . Let $\beta_i = \varphi\alpha_i$. The inverse image $u^{-1}C$ is the set of points q such that $p = uq$ is in C , i.e., such that $\alpha_i(uq) = \beta_i(q) = 0$ (2.7.4). So $u^{-1}C$ is the zero locus in Y of the elements $\beta_i = \varphi(\alpha_i)$ of B . It is a closed set.

The classical topology: We use the fact that polynomials are continuous functions. First, a morphism of affine spaces $\mathbb{A}_y^n \xrightarrow{\tilde{u}} \mathbb{A}_x^m$ is defined by an algebra homomorphism $\mathbb{C}[x_1, \dots, x_m] \xrightarrow{\Phi} \mathbb{C}[y_1, \dots, y_n]$, and this homomorphism is determined by the polynomials $h_1(y), \dots, h_m(y)$ that are the images of the variables x . The morphism \tilde{u} sends the point (y_1, \dots, y_n) of \mathbb{A}^n to the point $(h_1(y), \dots, h_m(y))$ of \mathbb{A}^m . It is continuous.

Next, a morphism $Y \xrightarrow{u} X$ is defined by a homomorphism $A \xrightarrow{\varphi} B$. We choose presentations $A = \mathbb{C}[x]/I$ and $B = \mathbb{C}[y]/J$, and we form a diagram of homomorphisms and the associated diagram of morphisms:

$$\begin{array}{ccc} \mathbb{C}[x] & \xrightarrow{\Phi} & \mathbb{C}[y] & & \mathbb{A}_x^n & \xleftarrow{\tilde{u}} & \mathbb{A}_y^m \\ \alpha \downarrow & & \downarrow \beta & & \uparrow & & \uparrow \\ A & \xrightarrow{\varphi} & B & & X & \xleftarrow{u} & Y \end{array}$$

Here α and β are the canonical maps of a ring to a quotient ring. The map α sends x_1, \dots, x_n to $\alpha_1, \dots, \alpha_n$. Then Φ is obtained by choosing elements h_i of $\mathbb{C}[y]$, such that $\beta(h_i) = \varphi(\alpha_i)$.

In the diagram of morphisms, \tilde{u} is continuous, and the vertical arrows are the embeddings of X and Y into their affine spaces. Since the topologies on X and Y are induced from their embeddings, u is continuous. \square

As we see here, every morphism of affine varieties can be obtained by restriction from a morphism of affine spaces. However, in the diagram above, the morphism \tilde{u} isn't unique. It depends on the presentations of A and B , and on the choice of the polynomials h_i .

2.8 Finite Group Actions

grpi

Let G be a finite group of automorphisms of a finite-type domain B . An *invariant* element of B is an element that is sent to itself by every element σ of G . For example, the product and the sum

invarelts (2.8.1)
$$\prod_{\sigma \in G} \sigma b \quad , \quad \sum_{\sigma \in G} \sigma b$$

are invariant elements. The invariant elements form a subalgebra of B that is often denoted by B^G . Theorem 2.8.5 below asserts that B^G is a finite-type algebra, and that points of $\text{Spec } B^G$ correspond bijectively to G -orbits in $\text{Spec } B$.

*actonpla-
neex*

2.8.2. Examples.

(i) The symmetric group $G = S_n$ operates on the polynomial ring $R = \mathbb{C}[x_1, \dots, x_n]$ by permuting the variables, and the Symmetric Functions Theorem asserts that the elementary symmetric functions

$$s_1 = \sum_i x_i, \quad s_2 = \sum_{i < j} x_i x_j, \quad \dots, \quad s_n = x_1 x_2 \cdots x_n$$

generate the ring R^G of invariant polynomials. Moreover, s_1, \dots, s_n are algebraically independent, so R^G is the polynomial algebra $\mathbb{C}[s_1, \dots, s_n]$. The inclusion of R^G into R gives us a morphism from affine x -space \mathbb{A}_x^n to affine s -space $\mathbb{A}_s^n = \text{Spec } R^G$. If $a = (a_1, \dots, a_n)$ is a point of \mathbb{A}_s^n , the points $b = (b_1, \dots, b_n)$ of \mathbb{A}_x^n that map to a are those such that $s_i(b) = a_i$. The components b_i are the roots of the polynomial $x^n - a_1 x^{n-1} + \cdots \pm a_n$. Since the roots form a G -orbit, the set of G -orbits of points of \mathbb{A}_x^n maps bijectively to \mathbb{A}_s^n .

(ii) Let $\zeta = e^{2\pi i/n}$, let σ be the automorphism of the polynomial ring $B = \mathbb{C}[y_1, y_2]$ defined by $\sigma y_1 = \zeta y_1$ and $\sigma y_2 = \zeta^{-1} y_2$. Let G be the cyclic group of order n generated by σ , and let A denote the algebra B^G of invariant elements. A monomial $m = y_1^i y_2^j$ is invariant if and only if n divides $i - j$, and an invariant polynomial is a linear combination of invariant monomials. You will be able to show that the three monomials

$$(2.8.3) \quad u_1 = y_1^n, \quad u_2 = y_2^n, \quad \text{and} \quad w = y_1 y_2 \quad \text{zetainvar}$$

generate A . We'll use the same symbols u_1, u_2, w to denote variables in the polynomial ring $\mathbb{C}[u_1, u_2, w]$. Let J be the kernel of the canonical homomorphism $\mathbb{C}[u_1, u_2, w] \xrightarrow{\tau} A$ that sends u_1, u_2 , and w to y_1^n, y_2^n , and $y_1 y_2$, respectively.

2.8.4. Lemma. *With notation as above, the kernel J of τ is the principal ideal of $\mathbb{C}[u_1, u_2, w]$ generated by the polynomial $f = w^n - u_1 u_2$.* slaction

proof. First, f is an element of J . Next, let $g(u_1, u_2, w)$ be an element of J . So $g(y_1^n, y_2^n, y_1 y_2) = 0$. We divide g by f , considered as a monic polynomial in w , say $g = fq + r$, where the remainder r has degree $< n$ in w . The remainder will be in J too: $r(y_1^n, y_2^n, y_1 y_2) = 0$. We write $r(u_1, u_2, w)$ as a polynomial in w : $r = r_0(u_1, u_2) + r_1(u_1, u_2)w + \cdots + r_{n-1}(u_1, u_2)w^{n-1}$. When we substitute $y_1^n, y_2^n, y_1 y_2$, the term $r_i(u_1, u_2)w^i$ becomes $r_i(y_1^n, y_2^n)(y_1 y_2)^i$. The degree in y_1 of every monomial that appears will be congruent to i modulo n , and the same is true for the degree of y_2 . Since $r(y_1^n, y_2^n, y_1 y_2) = 0$, and since the indices i are distinct, $r_i(y_1^n, y_2^n)$ will be zero for every i . And if $r_i(y_1^n, y_2^n)$ is zero, then $r_i(u_1, u_2) = 0$. So $r = 0$, which means that f divides g . □

We go back to the operation of the cyclic group on B and the algebra of invariants A . Let Y denote the affine plane $\text{Spec } B$, and let $X = \text{Spec } A$. The group G operates on Y , and except for the origin, which is a fixed point, the orbit of a point (y_1, y_2) consists of the n points $(\zeta^i y_1, \zeta^{-i} y_2)$, $i = 0, \dots, n-1$. To show that G -orbits in Y correspond bijectively to points of X , we fix complex numbers u_1, u_2, w with $w^n = u_1 u_2$, and we look for solutions of the equations (2.8.3). When $u_1 \neq 0$, the equation $u_1 = y_1^n$ has n solutions for y_1 , and then y_2 is determined by the equation $w = y_1 y_2$. So the fibre has order n . Similarly, there are n points in the fibre if $u_2 \neq 0$. If $u_1 = u_2 = 0$, then $y_1 = y_2 = w = 0$. In all cases, the fibres are the G -orbits. □

2.8.5. Theorem. *Let G be a finite group of automorphisms of a finite-type domain B , and let A denote the algebra B^G of invariant elements. Let $Y = \text{Spec } B$ and $X = \text{Spec } A$.* groupoper-

- (i) A is a finite-type domain and B is a finite A -module.
 - (ii) G operates by automorphisms on Y .
 - (iii) The morphism $Y \rightarrow X$ defined by the inclusion $A \subset B$ is surjective, and its fibres are the G -orbits of points of Y .
- one

When a group G operates on a set Y , one often denotes the set of G -orbits of Y by Y/G (read $Y \bmod G$). With that notation, the theorem asserts that there is a bijective map

$$Y/G \rightarrow X$$

proof of 2.8.5 (i): The invariant algebra $A = B^G$ is a finite-type algebra, and B is a finite A -module.

This is an interesting indirect proof. To show that A is a finite-type algebra, one constructs a finite-type subalgebra R of A such that B is a finite R -module.

Let $\{z_1, \dots, z_k\}$ be the G -orbit of an element z_1 of B . The orbit is the set of roots of the polynomial

$$f(t) = (t - z_1) \cdots (t - z_k) = t^k - s_1 t^{k-1} + \cdots \pm s_k \quad \text{spoly}$$

whose coefficients are the elementary symmetric functions in $\{z_1, \dots, z_k\}$. Let R_1 denote the algebra generated by those symmetric functions. Because the symmetric functions are invariant, $R_1 \subset A$. Using the equation $f(z_1) = 0$, we can write any power of z_1 as a polynomial in z_1 of degree less than k , with coefficients in R_1 .

We choose a finite set of generators $\{y_1, \dots, y_r\}$ for the algebra B . If the order of the orbit of y_j is k_j , then y_j will be the root of a monic polynomial f_j of degree k_j with coefficients in A . Let R denote the finite-type

algebra generated by all of the coefficients of all of the polynomials f_1, \dots, f_r . We can write any power of y_j as a polynomial in y_j with coefficients in R , and of degree less than k_j . Using such expressions, we can write every monomial in y_1, \dots, y_r as a polynomial with coefficients in R , whose degree in the variable y_j is less than k_j . Since y_1, \dots, y_r generate B , we can write every element of B as such a polynomial. Then the finite set of monomials $y_1^{e_1} \cdots y_r^{e_r}$ with $e_j < k_j$ spans B as an R -module. Therefore B is a finite R -module.

The algebra A of invariants is a subalgebra of B that contains R . So when regarded as an R -module, A is a submodule of the finite R -module B . Since R is a finite-type algebra, it is noetherian. Therefore A is also a finite R -module. When we put a finite set of algebra generators for R together with a finite set of R -module generators for A , we obtain a finite set of algebra generators for A . So A is a finite-type algebra. And, since B is a finite R -module, it is also a finite module over the larger ring A .

proof of 2.8.5(ii): The group G operates on Y .

A group element σ is a homomorphism $B \xrightarrow{\sigma} B$, which defines a morphism $Y \xleftarrow{u_\sigma} Y$, as in Definition 2.7.4. Since σ is an invertible homomorphism, i.e., an automorphism, u_σ is also an automorphism. Thus G operates on Y . However, there is a point that should be mentioned.

Let's write the operation of G on B on the left as usual, so that a group element σ maps an element β of B to $\sigma\beta$. Then if σ and τ are two group elements, the product $\sigma\tau$ acts as *first do τ , then σ* : $(\sigma\tau)\beta = \sigma(\tau\beta)$.

BBB (2.8.6)
$$B \xrightarrow{\tau} B \xrightarrow{\sigma} B$$

We substitute $u = u_\sigma$ into Definition 2.7.4: If q is a point of Y , the morphism $Y \xleftarrow{u_\sigma} Y$ sends q to the point p such that $\pi_p = \pi_q\sigma$. It seems permissible to drop the symbol u , and to write the morphism simply as $Y \xleftarrow{\sigma} Y$. But since arrows are reversed when going from homomorphisms of algebras to morphisms of their spectra, the maps displayed in (2.8.6), give us morphisms

YYY (2.8.7)
$$Y \xleftarrow{\tau} Y \xleftarrow{\sigma} Y$$

On $Y = \text{Spec } B$, the product $\sigma\tau$ acts as *first do σ , then τ* .

To get around this problem, we can put the symbol σ on the right when it operates on Y , so that σ sends a point q to $q\sigma$. Then if q is a point of Y , we will have $q(\sigma\tau) = (q\sigma)\tau$, as required of an operation.

- If G operates on the left on B , then it operates on the right on $\text{Spec } B$.

This is important only when one wants to compose morphisms. In Definition 2.7.4, we followed custom and wrote the morphism u that corresponds to an algebra homomorphism φ on the left. We will continue to write morphisms on the left when possible, but not here.

Let β be an element of B and let q be a point of Y . The value of the function $\sigma\beta$ at a point q is the same as the value of the function β at the point $q\sigma$: $[\sigma\beta](q) \stackrel{\text{defn}}{=} \pi_q(\sigma\beta) = \pi_{q\sigma}(\beta) \stackrel{\text{defn}}{=} \beta(q\sigma)$ (2.7.6):

bsigmay (2.8.8)
$$[\sigma\beta](q) = \beta(q\sigma) \quad \square$$

proof of 2.8.5 (iii): The fibres of the morphism $Y \rightarrow X$ are the G -orbits in Y .

We go back to the subalgebra $A = B^G$. For σ in G , we have a diagram of algebra homomorphisms and the corresponding diagram of morphisms

actonB (2.8.9)
$$\begin{array}{ccc} B & \xrightarrow{\sigma} & B & & Y & \xleftarrow{\sigma} & Y \\ \uparrow & & \uparrow & & \downarrow & & \downarrow \\ A & \xlongequal{\quad} & A & & X & \xlongequal{\quad} & X \end{array}$$

The diagram of morphisms shows that all points of Y that are in a G -orbit have the same image in X , and therefore that the set of G -orbits in Y , which we may denote by Y/G , maps to X . We show that the map $Y/G \rightarrow X$ is bijective.

arbvals **2.8.10. Lemma. (i)** *Let p_1, \dots, p_k be distinct points of affine space \mathbb{A}^n , and let c_1, \dots, c_k be complex numbers. There is a polynomial $f(x_1, \dots, x_n)$ such that $f(p_i) = c_i$ for $i = 1, \dots, k$.*

(ii) *Let B be a finite-type algebra, let q_1, \dots, q_k be points of $\text{Spec } B$, and let c_1, \dots, c_k be complex numbers. There is an element β in B such that $\beta(q_i) = c_i$ for $i = 1, \dots, k$. \square*

injectivity of the map $Y/G \rightarrow X$:

Let O_1 and O_2 be distinct G -orbits. Lemma 2.8.10 tells us that there is an element β in B whose value is 0 at every point of O_1 , and is 1 at every point of O_2 . Since G permutes the orbits, $\sigma\beta$ will also be 0 at points of O_1 and 1 at points of O_2 . Then the product $\gamma = \prod_{\sigma} \sigma\beta$ will be 0 at points of O_1 and 1 at points of O_2 , and the product γ is invariant. If p_i denotes the image in X of the orbit O_i , the maximal ideal \mathfrak{m}_{p_i} of A is the intersection $A \cap \mathfrak{m}_q$, where q is any point in O_i . Therefore γ is in the maximal ideal \mathfrak{m}_{p_1} , but not in \mathfrak{m}_{p_2} . The images of the two orbits are distinct.

surjectivity of the map $Y/G \rightarrow X$:

It suffices to show that the map $Y \rightarrow X$ is surjective.

2.8.11. Lemma. *If I is an ideal of the invariant algebra A , and if the extended ideal IB is the unit ideal of B , then I is the unit ideal of A .* *extideal*

As before, the extended ideal IB is the ideal of B generated by I .

Let's assume the lemma for the moment, and use it to prove surjectivity of the map $Y \rightarrow X$. Let p be a point of X . The lemma tells us that the extended ideal $\mathfrak{m}_p B$ isn't the unit ideal. So it is contained in a maximal ideal \mathfrak{m}_q of B , where q is a point of Y . Then $\mathfrak{m}_p \subset (\mathfrak{m}_p B) \cap A \subset \mathfrak{m}_q \cap A$.

The contraction $\mathfrak{m}_q \cap A$ is an ideal of A , and it isn't the unit ideal because 1 isn't in \mathfrak{m}_q . Since \mathfrak{m}_p is a maximal ideal, $\mathfrak{m}_p = \mathfrak{m}_q \cap A$. This means that q maps to p in X . □

proof of the lemma. If $IB = B$, there will be an equation $\sum_i z_i b_i = 1$, with z_i in I and b_i in B . The sums $\alpha_i = \sum_{\sigma} \sigma b_i$ are invariant, so they are elements of A , and the elements z_i are invariant. Therefore $\sum_{\sigma} \sigma(z_i b_i) = z_i \sum_{\sigma} \sigma b_i = z_i \alpha_i$ is in I . Then

$$\sum_{\sigma} 1 = \sum_{\sigma} \sigma(1) = \sum_{\sigma, i} \sigma(z_i b_i) = \sum_i z_i \alpha_i$$

The right side is in I , and the left side is the order of the group which, because A contains the complex numbers, is an invertible element of A . So I is the unit ideal. □

2.9 Exercises

- 2.9.1.** Prove that if $f(x_0, x_1, x_2)$ is an irreducible homogeneous polynomial, not x_0 , then its dehomogenization $f(1, x_1, x_2)$ is also irreducible.
- 2.9.2.** Describe all prime ideals of the two-variable polynomial ring $\mathbb{C}[x, y]$.
- 2.9.3.** Prove that the varieties in the affine plane \mathbb{A}^2 are points, curves, and the affine plane \mathbb{A}^2 itself.
- 2.9.4.** Derive version 1 of the Nullstellensatz from the Strong Nullstellensatz.
- 2.9.5.** Classify algebras that are complex vector spaces of dimensions two and three.
- 2.9.6.** Prove that, in the ring $\mathbb{C}[[x_1, \dots, x_n]]$ of formal power series, an element whose constant term is nonzero is invertible.
- 2.9.7.** Find generators for the ideal of $\mathbb{C}[x, y]$ of polynomials that vanish on the three points $(0, 0)$, $(0, 1)$, $(1, 0)$.
- 2.9.8.** Let B be a finite type domain, and let p and q be points of the affine variety $Y = \text{Spec } B$. Let A be the set of elements $f \in B$ such that $f(p) = f(q)$. Prove
- A is a finite type domain.
 - B is a finite A -module.
 - Let $\varphi : \text{Spec } B \rightarrow \text{Spec } A$ be the morphism obtained from the inclusion $A \subset B$. Show that $\varphi(p) = \varphi(q)$, and that φ is bijective everywhere else.
- 2.9.9.** Prove that if a noetherian ring contains just one prime ideal, then that ideal is nilpotent.
- 2.9.10.** Let I_1, \dots, I_k and J ideals of a finite-type domain, such that $J \not\subset I_j$ for any j . Prove that there is an element $x \in J$ that isn't contained in I_j for any j .
- 2.9.11.** Prove that, if an algebra A is a complex vector space of dimension d , it contains at most d maximal ideals.
- 2.9.12.** Let A be a noetherian ring. Prove that a radical ideal I of A is the intersection of finitely many prime ideals.
- 2.9.13.** A minimal prime ideal is an ideal that doesn't properly contain any other prime ideal. Prove that a nonzero, finite-type algebra A (not necessarily a domain) contains at least one and only finitely many minimal prime ideals. Try to find a proof that doesn't require much work.
- 2.9.14.** The equation $y^2 = x^3$ defines a plane curve X with a cusp at the origin, the spectrum of the algebra $A = \mathbb{C}[x, y]/(y^2 - x^3)$. There is a homomorphism $A \xrightarrow{\varphi} \mathbb{C}[t]$, with $\varphi(x) = t^2$ and $\varphi(y) = t^3$, and the associated morphism $\mathbb{A}^1 \xrightarrow{u} X$ sends a point t of \mathbb{A}^1 to the point $(x, y) = (t^2, t^3)$ of X . Prove that u is a homeomorphism in the Zariski topology and also in the classical topology.
- 2.9.15.** Let T denote the ring $\mathbb{C}[\epsilon]$, with $\epsilon^2 = 0$. If A is the coordinate ring of an affine variety X , an (infinitesimal) tangent vector to X is, by definition, given by an algebra homomorphism $\varphi : A \rightarrow T$.
- Show that such a homomorphism can be written in the form $\varphi(a) = f(a) + d(a)\epsilon$, where f and d are functions $A \rightarrow \mathbb{C}$. Show that f is an algebra homomorphism, and that d is an f -derivation, a linear map that satisfies the identity $d(ab) = f(a)d(b) + d(a)f(b)$.
 - Show that, when $A = \mathbb{C}[x_1, \dots, x_n]/(f_1, \dots, f_r)$ the tangent vectors are defined by the equations $\nabla f_i(p)x = 0$.
- 2.9.16.** Explain what a morphism $\text{Spec } B \rightarrow \text{Spec } A$ means in terms of polynomials, when $A = \mathbb{C}[x_1, \dots, x_m]/(f_1, \dots, f_r)$ and $B = \mathbb{C}[y_1, \dots, y_n]/(g_1, \dots, g_k)$.
- 2.9.17.** Let $A = \mathbb{C}[x_1, \dots, x_2]$, and let $B = A[\alpha]$, where α is an element of the fraction field $\mathbb{C}(x)$ of A . Describe the fibres of the morphism $Y = \text{Spec } B \rightarrow \text{Spec } A = X$.
- 2.9.18.** Let X be the plane curve $y^2 = x(x-1)^2$, let $A = \mathbb{C}[x, y]/(y^2 - x(x-1)^2)$ be its coordinate algebra, and let x, y denote the residues of those elements in A too.
- Points of the curve can be parametrized by a variable t . Use the lines $y = t(x-1)$ to determine such a parametrization.
 - Let $B = \mathbb{C}[t]$ and let T be the affine line $\text{Spec } \mathbb{C}[t]$. The parametrization gives us an injective homomorphism $A \rightarrow B$. Describe the corresponding morphism $T \rightarrow X$.

- 2.9.19.** Show that the algebra $A = \mathbb{C}[x, y]/(x^2 + y^2 - 1)$ is isomorphic to the Laurent Polynomial Ring $\mathbb{C}[t, t^{-1}]$, but that $\mathbb{R}[x, y]/(x^2 + y^2 - 1)$ is not isomorphic to $\mathbb{R}[t, t^{-1}]$. excircle
- 2.9.20.** Let C and D be closed subsets of an affine variety $X = \text{Spec } A$. Suppose that no component of D is contained in C . Prove that there is a regular function f that vanishes on C and isn't identically zero on any component of D . exnotvanish
- 2.9.21.** Let K be a field and let R be the polynomial ring $K[x_1, \dots, x_n]$, with $n > 0$. Prove that the field of fractions of R is not a finitely generated K -algebra. franotfg
- 2.9.22.** Let $A = \mathbb{C}[u, v]/(v^2 - u(1 - u))$ and $B = \mathbb{C}[x, y]/(x^2 + y^2 - 1)$, and let $X = \text{Spec } A, Y = \text{Spec } B$. Show that the substitution $u = x^2, v = xy$ defines a morphism $Y \rightarrow X$. xamorph
- 2.9.23.** Let X be the affine line $\text{Spec } \mathbb{C}[x]$. Considering $P = \text{Spec } \mathbb{C}[x_1, x_2]$ as the product $X \times X$, determine all morphisms $P \rightarrow X$ that define group laws on X . grplawonAone
- 2.9.24.** The cyclic group $G = \langle \sigma \rangle$ of order n operates on the polynomial algebra $A = \mathbb{C}[x, y]$ by $\sigma(x) = \zeta x$ and $\sigma(y) = \zeta y$, where $\zeta = e^{2\pi i/n}$. xzetaxy
- (a) Describe the invariant ring A^G by exhibiting generators and defining relations.
- (b) Prove that there is a $2 \times n$ matrix whose 2×2 -minors are defining relations for A^G .
- (c) Prove directly that the morphism $\text{Spec } A = \mathbb{A}^2 \rightarrow \text{Spec } B$ defined by the inclusion $B \subset A$ is surjective, and that its fibres are the G -orbits.

Chapter 3 PROJECTIVE ALGEBRAIC GEOMETRY

projgeom

- 3.1 Projective Varieties
- 3.2 Homogeneous Ideals
- 3.3 Product Varieties
- 3.4 Rational Functions
- 3.5 Morphisms and Isomorphisms
- 3.6 Affine Varieties
- 3.7 Lines in Projective Three-Space

3.1 Projective Varieties

pvariety

The projective space \mathbb{P}^n of dimension n was described in Chapter 1. Its points are equivalence classes of nonzero vectors (x_0, \dots, x_n) , the equivalence relation being that, for any nonzero complex number λ ,

xlambdax

$$(3.1.1) \quad (x_0, \dots, x_n) \sim (\lambda x_0, \dots, \lambda x_n).$$

A subset of \mathbb{P}^n is *Zariski closed* if it is the set of common zeros of a family of *homogeneous* polynomials f_1, \dots, f_k in the coordinate variables x_0, \dots, x_n , or if it is the set of zeros of the ideal \mathcal{I} generated by such a family. (Homogeneity is required because the vectors (x) and (λx) represent the same point of \mathbb{P}^n .) As explained in (1.3.1), $f(\lambda x) = 0$ for all λ if and only if f is homogeneous. The closed sets in the *Zariski topology* on \mathbb{P}^n are the Zariski closed sets. We usually refer to the Zariski closed sets simply as *closed sets*.

Because the polynomial ring $\mathbb{C}[x_0, \dots, x_n]$ is noetherian, \mathbb{P}^n is a noetherian space: Every strictly increasing family of ideals of $\mathbb{C}[x]$ is finite, and every strictly decreasing family of closed subsets of \mathbb{P}^n is finite. Therefore every closed subset of \mathbb{P}^n is a finite union of irreducible closed sets (2.2.15). The irreducible closed sets are the *projective varieties*. They are the closed subvarieties of \mathbb{P}^n . Thus every projective variety X is an irreducible closed subset of some projective space.

We will want to know when two projective varieties are isomorphic. This will be explained in Section 3.5, where morphisms are defined.

The Zariski topology on a projective variety X is induced from the topology on the projective space that contains it. Since a projective variety X is closed in \mathbb{P}^n , a subset of X is closed in X if it is closed in \mathbb{P}^n .

point-closed

3.1.2. Lemma. *The one-point sets in projective space are closed.*

proof. This simple proof illustrates a general method. Let p be the point (a_0, \dots, a_n) . The first guess might be that the one-point set $\{p\}$ is defined by the equations $x_i = a_i$, but the polynomials $x_i - a_i$ aren't homogeneous in x . This is reflected in the fact that, for any $\lambda \neq 0$, the vector $(\lambda a_0, \dots, \lambda a_n)$ represents the same point, though it won't satisfy those equations. The equations that define the set $\{p\}$ are

define-point

$$(3.1.3) \quad a_i x_j = a_j x_i,$$

for $i, j = 0, \dots, n$, which imply that the ratios a_i/a_j and x_i/x_j are equal. □

closedin-line

3.1.4. Lemma. *The proper closed subsets of the projective line are its nonempty finite subsets, and the proper closed subsets of the projective plane are finite unions of points and curves.* □

Though affine varieties are important, most of algebraic geometry concerns projective varieties. It won't be clear why this is so, but one property of projective space gives a hint of its importance: With its classical topology, projective space is *compact*.

A topological space is compact if it has these properties:

Hausdorff property: Distinct points p, q of X have disjoint open neighborhoods, and

quasicompactness: If X is covered by a family $\{U^i\}$ of open sets, then a finite subfamily covers X .

By the way, when we say that the sets $\{U^i\}$ *cover* a topological space X , we mean that X is the union $\bigcup U^i$. We don't allow U^i to contain elements that aren't in X , though that would be a customary English usage.

In the classical topology, affine space \mathbb{A}^n isn't quasicompact, and therefore it isn't compact. The *Heine-Borel Theorem* asserts that a subset of \mathbb{A}^n is compact in the classical topology if and only if it is closed and bounded.

We'll show that \mathbb{P}^n is compact, assuming that the Hausdorff property has been verified. The $2n + 1$ -dimensional sphere \mathbb{S} of unit length vectors in \mathbb{A}^{n+1} is a bounded set, and because it is the zero locus of the equation $\bar{x}_0x_0 + \cdots + \bar{x}_nx_n = 1$, it is closed. The Heine-Borel Theorem tells us that \mathbb{S} is compact. The map $\mathbb{S} \rightarrow \mathbb{P}^n$ that sends a vector (x_0, \dots, x_n) to the point of projective space with that coordinate vector is continuous and surjective, so the next lemma of topology shows that \mathbb{P}^n is compact.

3.1.5. Lemma. *Let $Y \xrightarrow{f} X$ be a continuous map. Suppose that Y is compact and that X is a Hausdorff space. Then the image $Z = f(Y)$ is a closed, compact subset of X .* □

image-compact

The rest of this section contains a few examples of projective varieties.

(3.1.6) linear subspaces

linsubsp

If W is a subspace of dimension $r + 1$ of the vector space V , the points of \mathbb{P}^n that are represented by the nonzero vectors in W form a *linear subspace* L of \mathbb{P}^n , of dimension r . If (w_0, \dots, w_r) is a basis of W , the linear subspace L corresponds bijectively to a projective space of dimension r , by

$$c_0w_0 + \cdots + c_rw_r \longleftrightarrow (c_0, \dots, c_r)$$

For example, the set of points $(x_0, \dots, x_r, 0, \dots, 0)$ is a linear subspace of dimension r . □

(3.1.7) a quadric surface

quadric-surface

A *quadric* in projective three-space \mathbb{P}^3 is the locus of zeros of an irreducible homogeneous quadratic equation in four variables.

We describe a bijective map from the product $\mathbb{P}^1 \times \mathbb{P}^1$ of projective lines to a quadric. Let coordinates in the two copies of \mathbb{P}^1 be (x_0, x_1) and (y_0, y_1) , respectively, and let the four coordinates in \mathbb{P}^3 be w_{ij} , with $0 \leq i, j \leq 1$. The map is defined by $w_{ij} = x_iy_j$. Its image is the quadric Q whose equation is

$$(3.1.8) \quad w_{00}w_{11} = w_{01}w_{10}$$

ponepone

Let's check that the map $\mathbb{P}^1 \times \mathbb{P}^1 \rightarrow Q$ is bijective. If w is a point of Q , one of the coordinates, say w_{00} , will be nonzero. Then if (x, y) is a point of $\mathbb{P}^1 \times \mathbb{P}^1$ whose image is w , so that $w_{ij} = x_iy_j$, the coordinates x_0 and y_0 must be nonzero. When we normalize w_{00}, x_0 , and y_0 to 1, $w_{11} = w_{01}w_{10}$. There is a unique solution for x and y such that $w_{ij} = x_iy_j$, namely $x_1 = w_{10}$ and $y_1 = w_{01}$.

The quadric with the equation (3.1.8) contains two families of *lines* (one dimensional linear subspaces), the images of the subsets $x \times \mathbb{P}^1$ and $\mathbb{P}^1 \times y$ of $\mathbb{P}^1 \times \mathbb{P}^1$.

Note. Equation (3.1.8) can be diagonalized by the substitution $w_{00} = s + t$, $w_{11} = s - t$, $w_{01} = u + v$, $w_{10} = u - v$. This substitution changes the equation (3.1.8) to $s^2 - t^2 = u^2 - v^2$. When we look at the affine

open set $\{u = 1\}$, the equation becomes $s^2 + v^2 - t^2 = 1$. The real locus of this equation is a one-sheeted hyperboloid in \mathbb{R}^3 , and the two families of complex lines in the quadric correspond to the familiar rulings of this hyperboloid by real lines.

hsurftwo **(3.1.9) hypersurfaces**

A *hypersurface* in projective space \mathbb{P}^n is the locus of zeros of an irreducible homogeneous polynomial $f(x_0, \dots, x_n)$. The *degree* of Y is the degree of the polynomial f .

Plane projective curves and quadric surfaces are hypersurfaces.

segreemb **(3.1.10) the Segre embedding of a product**

The product $\mathbb{P}_x^m \times \mathbb{P}_y^n$ of projective spaces can be embedded by its *Segre embedding* into a projective space \mathbb{P}_w^N that has coordinates w_{ij} , with $i = 0, \dots, m$ and $j = 0, \dots, n$. So $N = (m+1)(n+1) - 1$. The Segre embedding is defined by

segreco-ords (3.1.11)
$$w_{ij} = x_i y_j$$

We call the coordinates w_{ij} the *Segre variables*.

The map from $\mathbb{P}^1 \times \mathbb{P}^1$ to \mathbb{P}^3 that was described in (3.1.7) is the simplest case of a Segre embedding.

segreeq **3.1.12. Proposition.** *The Segre embedding maps the product $\mathbb{P}^m \times \mathbb{P}^n$ bijectively to the locus S of the Segre equations*

segree-uations (3.1.13)
$$w_{ij} w_{kl} - w_{il} w_{kj} = 0$$

proof. The proof is analogous to the one given in (3.1.7). When one substitutes (3.1.11) into the Segre equations, one obtains equations in $\{x_i, y_j\}$ that are true. So the image of the Segre embedding is contained in S .

Say that we have a point p of the locus S , that is the image of a point (x, y) of $\mathbb{P}^m \times \mathbb{P}^n$. Some coordinate of p , say w_{00} , will be nonzero, and then x_0 and y_0 are also nonzero. We normalize w_{00}, x_0 , and y_0 to 1. Then $w_{ij} = w_{i0} w_{0j}$ for all i, j . The unique solution of the Segre equations is $x_i = w_{i0}$ and $y_j = w_{0j}$. \square

The Segre embedding is important because it makes the product of projective spaces into a projective variety, the closed subvariety of \mathbb{P}^N defined by the Segre equations. However, to show that the product is a variety, we need to show that the locus S of the Segre equations is irreducible. This is less obvious than one might expect, so we defer the discussion to Section 3.3 (see Proposition 3.3.1).

verone-seemb **(3.1.14) the Veronese embedding of projective space**

Let the coordinates in \mathbb{P}^n be x_i , and let those in \mathbb{P}^N be v_{ij} , with $0 \leq i \leq j \leq n$. So $N = \binom{n+2}{2} - 1$. The Veronese embedding is the map $\mathbb{P}^n \xrightarrow{f} \mathbb{P}^N$ defined by $v_{ij} = x_i x_j$. The Veronese embedding resembles the Segre embedding, but in the Segre embedding, there are distinct sets of coordinates x and y , and $i \leq j$ isn't required.

The proof of the next proposition is similar to the proof of (3.1.12), once one has untangled the inequalities.

veroneq **3.1.15. Proposition.** *The Veronese embedding f maps \mathbb{P}^n bijectively to the locus X in \mathbb{P}^N of the equations*

$$v_{ij} v_{kl} = v_{il} v_{kj} \quad \text{for } 0 \leq i \leq k \leq j \leq \ell \leq n \quad \square$$

For example, the Veronese embedding maps \mathbb{P}^1 bijectively to the conic $v_{00} v_{11} = v_{01}^2$ in \mathbb{P}^2 .

(3.1.16) the twisted cubic

twistcubic

There are higher order Veronese embeddings, defined in an analogous way by the monomials of some degree $d > 2$. The first example is the embedding of \mathbb{P}^1 by the cubic monomials in two variables, which maps \mathbb{P}_x^1 to \mathbb{P}_v^3 . Let the coordinates in \mathbb{P}^3 be v_0, \dots, v_3 . The cubic Veronese embedding is defined by

$$v_0 = x_0^3, \quad v_1 = x_0^2x_1, \quad v_2 = x_0x_1^2, \quad v_3 = x_1^3$$

Its image is a *twisted cubic* in \mathbb{P}^3 , the locus $(v_0, v_1, v_2, v_3) = (x_0^3, x_0^2x_1, x_0x_1^2, x_1^3)$. This locus is the set of common zeros of the three polynomials

(3.1.17)
$$v_0v_2 - v_1^2, \quad v_1v_2 - v_0v_3, \quad v_1v_3 - v_2^2$$

twcubic

They are the 2×2 minors of the 2×3 matrix

(3.1.18)
$$\begin{pmatrix} v_0 & v_1 & v_2 \\ v_1 & v_2 & v_3 \end{pmatrix}$$

twothree-matrix

A 2×3 matrix has rank ≤ 1 if and only if its 2×2 minors are zero. So a point (v_0, v_1, v_2, v_3) lies on the twisted cubic if (3.1.18) has rank one. This means that if the vectors (v_0, v_1, v_2) and (v_1, v_2, v_3) are both nonzero, they represent the same point of \mathbb{P}^2 . Setting $x_0 = 1$ and $x_1 = t$, the twisted cubic becomes the locus of points $(1, t, t^2, t^3)$. There is also one point on the twisted cubic at which $x_0 = 0$, the point $(0, 0, 0, 1)$. \square

3.2 Homogeneous Ideals

We denote the polynomial algebra $\mathbb{C}[x_0, \dots, x_n]$ by R here.

homogen

3.2.1. Lemma. *Let \mathcal{I} be an ideal of R . The following conditions are equivalent.*

ho-mogideal

(i) \mathcal{I} can be generated by homogeneous polynomials.

(ii) A polynomial is in \mathcal{I} if and only if its homogeneous parts are in \mathcal{I} . \square

An ideal \mathcal{I} of R that satisfies these conditions is a *homogeneous ideal*.

3.2.2. Lemma. *The radical (2.2.2) of a homogeneous ideal is homogeneous.*

radicalho-mogeneous

proof. Let \mathcal{I} be a homogeneous ideal, and let f be an element of its radical $\text{rad } \mathcal{I}$. So f^r is in \mathcal{I} for some r . When f is written as a sum $f_0 + \dots + f_d$ of its homogeneous parts, the highest degree part of f^r is $(f_d)^r$. Since \mathcal{I} is homogeneous, $(f_d)^r$ is in \mathcal{I} and f_d is in $\text{rad } \mathcal{I}$. Then $f_0 + \dots + f_{d-1}$ is also in $\text{rad } \mathcal{I}$. By induction on d , all of the homogeneous parts f_0, \dots, f_d are in $\text{rad } \mathcal{I}$. \square

3.2.3. If f is a set of homogeneous polynomials, its set of zeros in \mathbb{P}^n may be denoted by $V(f)$ or $V_{\mathbb{P}^n}(f)$, and the set of zeros of a homogeneous ideal \mathcal{I} may be denoted by $V(\mathcal{I})$ or $V_{\mathbb{P}^n}(\mathcal{I})$. This is the same notation as is used for closed subsets of affine space.

defVXI

The complement of the origin in the affine space \mathbb{A}^{n+1} is mapped to the projective space \mathbb{P}^n by sending a vector (x_0, \dots, x_n) to the point of \mathbb{P}^n it defines. This map can be useful when one studies projective space.

A homogeneous ideal \mathcal{I} has a zero locus in projective space \mathbb{P}^n and also a zero locus in the affine space \mathbb{A}^{n+1} . We can't use the $V(\mathcal{I})$ notation for both of them here, so let's denote these two loci by V and W , respectively. Unless \mathcal{I} is the unit ideal, the origin $x = 0$ will be a point of W , and the complement of the origin will map surjectively to V . If a point x other than the origin is in W , then every point of the one-dimensional subspace of \mathbb{A}^{n+1} spanned by x is in W , because a homogeneous polynomial f vanishes at x if and only if it vanishes at λx . An affine variety that is the union of such lines through the origin is called an *affine cone*. If the locus W contains a point x other than the origin, it is an affine cone.

The locus $x_0^2 + x_1^2 - x_2^2 = 0$ is a cone in \mathbb{A}^3 . The locus $x_0^3 + x_1^3 - x_2^3 = 0$ is also a cone.

Note. The real locus $x_0^2 + x_1^2 - x_2^2 = 0$ in \mathbb{R}^3 decomposes into two parts when the origin is removed. Because of this, it is sometimes called a "double cone". However, the complex locus doesn't decompose.

irrel **(3.2.4) the irrelevant ideal**

In the polynomial algebra $R = \mathbb{C}[x_0, \dots, x_n]$, the maximal ideal $\mathcal{M} = (x_0, \dots, x_n)$ that is generated by the variables is called the *irrelevant ideal* because its zero locus in projective space is empty.

nozeros **3.2.5. Proposition.** *The zero locus in \mathbb{P}^n of a homogeneous ideal \mathcal{I} of R is empty if and only if \mathcal{I} contains a power of the irrelevant ideal \mathcal{M} .*

Another way to say this is that the zero locus $V(\mathcal{I})$ in projective space of a homogeneous ideal \mathcal{I} is empty if and only if either \mathcal{I} is the unit ideal R , or $\text{rad } \mathcal{I}$ is the irrelevant ideal.

proof of Proposition 3.2.5. Let Z be the zero locus of \mathcal{I} in \mathbb{P}^n . If \mathcal{I} contains a power of \mathcal{M} , it contains a power of each variable. Powers of the variables have no common zeros in projective space, so Z is empty.

Suppose that Z is empty, and let W be the locus of zeros of \mathcal{I} in the affine space \mathbb{A}^{n+1} with the same coordinates x_0, \dots, x_n . Since the complement of the origin in W maps to the empty locus Z , it is empty. The origin is the only point that might be in W . If W is the one point space consisting of the origin, then $\text{rad } \mathcal{I} = \mathcal{M}$. If W is empty, \mathcal{I} is the unit ideal. \square

homprime **3.2.6. Lemma.** *Let \mathcal{P} be a homogeneous ideal in the polynomial algebra R , not the unit ideal. The following conditions are equivalent:*

- (i) \mathcal{P} is a prime ideal.
- (ii) If f and g are homogeneous polynomials, and if $fg \in \mathcal{P}$, then $f \in \mathcal{P}$ or $g \in \mathcal{P}$.
- (iii) If \mathcal{A} and \mathcal{B} are homogeneous ideals, and if $\mathcal{A}\mathcal{B} \subset \mathcal{P}$, then $\mathcal{A} \subset \mathcal{P}$ or $\mathcal{B} \subset \mathcal{P}$.

In other words, a homogeneous ideal is a prime ideal if the usual conditions for a prime ideal are satisfied when the polynomials or ideals are homogeneous.

proof of the lemma. When the word homogeneous is omitted, (ii) and (iii) become the definition of a prime ideal. So (i) implies (ii) and (iii). The fact that (iii) \Rightarrow (ii) is proved by considering the principal ideals generated by f and g .

(ii) \Rightarrow (i) Suppose that a homogeneous ideal \mathcal{P} satisfies the condition (ii), and that the product fg of two polynomials, not necessarily homogeneous, is in \mathcal{P} . If f has degree d and g has degree e , the highest degree part of fg is the product $f_d g_e$ of the homogeneous parts of f and g of maximal degree. Since \mathcal{P} is a homogeneous ideal, it contains $f_d g_e$. Therefore one of the factors, say f_d , is in \mathcal{P} . Let $h = f - f_d$. Then $hg = fg - f_d g$ is in \mathcal{P} , and it has lower degree than fg . By induction on the degree of fg , h or g is in \mathcal{P} , and if h is in \mathcal{P} , so is f . \square

closedirred **3.2.7. Proposition.** *Let Y be the zero locus in \mathbb{P}^n of a homogeneous radical ideal \mathcal{I} , an ideal that is equal to its radical, and that isn't the irrelevant ideal. Then Y is a projective variety (an irreducible closed subset of \mathbb{P}^n) if and only if \mathcal{I} is a prime ideal. Thus a subset Y of \mathbb{P}^n is a projective variety if and only if it is the zero locus of a homogeneous prime ideal that isn't the irrelevant ideal.*

proof. The locus W of zeros of \mathcal{I} in the affine space \mathbb{A}^{n+1} is irreducible if and only if Y is irreducible. This is easy to see. Proposition 2.2.20 tells us that W is irreducible if and only if the radical ideal \mathcal{I} is a prime ideal. \square

homstrnull **3.2.8. Strong Nullstellensatz, projective version.**

- (i) Let g be a nonconstant homogeneous polynomial in x_0, \dots, x_n , and let \mathcal{I} be a homogeneous ideal of $\mathbb{C}[x]$. If g vanishes at every point of the zero locus $V(\mathcal{I})$ in \mathbb{P}^n , then \mathcal{I} contains a power of g .
- (ii) Let f and g be homogeneous polynomials. If f is irreducible and if $V(f) \subset V(g)$, then f divides g .
- (iii) Let \mathcal{I} and \mathcal{J} be homogeneous ideals, and suppose that $\text{rad } \mathcal{I}$ isn't the irrelevant ideal or the unit ideal. Then $V(\mathcal{I}) = V(\mathcal{J})$ if and only if $\text{rad } \mathcal{I} = \text{rad } \mathcal{J}$.

proof. (i) Let W be the locus of zeros of \mathcal{I} in the affine space \mathbb{A}^{n+1} with coordinates x_0, \dots, x_n . The homogeneous polynomial g vanishes at every point of W different from the origin, and since g isn't a constant, it vanishes at the origin too. So the affine Strong Nullstellensatz applies. \square

(3.2.9) quasiprojective varieties

var-
quasiproj

We will also want to consider nonempty open subsets of projective varieties. We will call such a subset a *variety* too.

For example, the complement of a point in a projective variety will be called a variety. An affine variety $X = \text{Spec } A$ may be embedded as a closed subvariety into the standard affine space $\mathbb{U}^0 : \{x_0 \neq 0\}$. It becomes an open subset of its closure in \mathbb{P}^n , which is a projective variety (Lemma 2.2.17 (ii)). And of course, a projective variety is a variety. The topology on a (quasiprojective) variety is induced from the topology on projective space.

Elsewhere, such a variety is usually called a *quasiprojective variety*, but we drop the adjective 'quasiprojective'. There are abstract varieties that cannot be embedded into any projective space. They aren't quasiprojective. But such varieties aren't very important. We won't study them. In fact, it is hard enough to find convincing examples of such varieties that we won't try to give one here. So for us, the adjective 'quasiprojective' is superfluous as well as ugly.

3.2.10. Lemma. *The topology on the affine open subset $\mathbb{U}^0 : x_0 \neq 0$ of \mathbb{P}^n that is induced from the Zariski topology on \mathbb{P}^n is same as the Zariski topology that is obtained by viewing \mathbb{U}^0 as the affine space $\text{Spec } \mathbb{C}[u_1, \dots, u_n]$, $u_i = x_i/x_0$.* □

topon-
standaff

3.3 Product Varieties

The properties of products of varieties seem intuitive, but some of the proofs aren't obvious. The reason is that the (Zariski) topology on a product of varieties isn't the product topology.

prodvar

The *product topology* on the product $X \times Y$ of topological spaces is the coarsest topology such that the projection maps $X \times Y \rightarrow X$ and $X \times Y \rightarrow Y$ are continuous. If C and D are closed subsets of X and Y , then $C \times D$ is a closed subset of $X \times Y$ in the product topology, and every closed set in the product topology is a finite union of such subsets.

The first examples of closed subsets of $\mathbb{P}^m \times \mathbb{P}^n$ are products of the form $C \times D$, where C is a closed subset of \mathbb{P}^m and D is a closed subset of \mathbb{P}^n . But the product topology on $\mathbb{P}^m \times \mathbb{P}^n$ is much coarser than the Zariski topology. For example, the proper (Zariski) closed subsets of \mathbb{P}^1 are the nonempty finite subsets. In the product topology, the proper closed subsets of $\mathbb{P}^1 \times \mathbb{P}^1$ are finite unions of sets of the form $\mathbb{P}^1 \times q$, $p \times \mathbb{P}^1$, and $p \times q$ ('horizontal lines', 'vertical' lines, and points). Most Zariski closed subsets of $\mathbb{P}^1 \times \mathbb{P}^1$ aren't of this form. The diagonal $\Delta = \{(p, p) \mid p \in \mathbb{P}^1\}$ is a simple example (see 3.5.18).

3.3.1. Proposition. *Suppose that a topology is given on the product $\Pi = X \times Y$ of two irreducible topological spaces, with the following*

Pirred

- The projections $\Pi \xrightarrow{\pi_1} X$ and $\Pi \xrightarrow{\pi_2} Y$ are continuous.
 - For all x in X and all y in Y , the fibres $x \times Y$ and $X \times y$ are homeomorphic to Y and X , respectively.
- Then Π is an irreducible topological space.

The first condition means that the topology on $X \times Y$ is at least as fine as the product topology, and the second one assures us that the topology isn't too fine. (We don't want the discrete topology on Π .)

The product of varieties has the two properties mentioned in the proposition.

3.3.2. Lemma. *Let X, Y , and Π be as in the proposition. If W is an open subset of Π , its image U via the projection $\Pi \rightarrow Y$ is an open subset of Y .*

projopen

proof. The intersection ${}_x W = W \cap (x \times Y)$ is an open subset of the fibre $x \times Y$, and its image ${}_x U$ in the homeomorphic space Y is open too. Since W is the union of the sets ${}_x W$, U is the union of the open sets ${}_x U$. So U is open. □

proof of Proposition 3.3.1. Let C and C' be closed subsets of the product Π . Suppose that $C < \Pi$ and $C' < \Pi$, and let $W = \Pi - C$ and $W' = \Pi - C'$ be the open complements of C and C' in Π . To show that Π is irreducible, we must show that $C \cup C' < \Pi$. We do this by showing that $W \cap W'$ is not the empty set.

Since $C < \Pi$, W isn't empty. Similarly, W' isn't empty. The lemma tells us that the images U and U' of W and W' via projection to Y are nonempty open subsets of Y . Since Y is irreducible, $U \cap U'$ is nonempty. Let y be a point of $U \cap U'$. The intersection $W_y = W \cap (X \times y)$ is an open subset of $X \times y$, and since its image U contains y , W_y contains a point of the form $p = (x, y)$. Thus W_y is a nonempty open subset of $X \times y$. Similarly, $W'_y = W' \cap (X \times y)$ is nonempty. Since $X \times y$ is homeomorphic to the irreducible space X , it is irreducible. So $W_y \cap W'_y$ is nonempty, and therefore $W \cap W'$ is nonempty, as was to be shown. \square

(3.3.3) products of affine varieties

We inspect the product $X \times Y$ of the affine varieties $X = \text{Spec } A$ and $Y = \text{Spec } B$. Say that X is embedded as a closed subvariety of \mathbb{A}^m , so that $A = \mathbb{C}[x_1, \dots, x_m]/P$ for some prime ideal P , and that Y is embedded similarly into \mathbb{A}^n , so that $B = \mathbb{C}[y_1, \dots, y_n]/Q$ for some prime ideal Q . Then in affine x, y -space \mathbb{A}^{m+n} , $X \times Y$ is the locus of the equations $f(x) = 0$ and $g(y) = 0$ with $f \in P$ and $g \in Q$. Proposition 3.3.1 shows that $X \times Y$ is irreducible, so it is a variety. Let P' be the ideal of $\mathbb{C}[x, y]$ generated by the elements of P . It consists of sums of products of elements of P with polynomials in x, y . Let Q' be defined analogously using Q , and let $I = P' + Q'$.

fgprime **3.3.4. Proposition.** *The ideal $I = P' + Q'$ consists all elements of $\mathbb{C}[x, y]$ that vanish on the variety $X \times Y$. Therefore I is a prime ideal.*

(The fact that $X \times Y$ is a variety tells us only that the radical of I is a prime ideal.)

proof of Proposition 3.3.4. Let $A = \mathbb{C}[x]/P$, $B = \mathbb{C}[y]/Q$, and $R = \mathbb{C}[x, y]/I$. Any polynomial in x, y can be written, in many ways, as a sum, each of whose terms is a product of a polynomial in x with a polynomial in y : $F(x, y) = \sum a_i(x)b_i(y)$. Therefore any element ρ of R can be written as a finite sum

pab (3.3.5)
$$\rho = \sum_{i=1}^k a_i b_i$$

with a_i in A and b_i in B . We show that if ρ vanishes identically on $X \times Y$, then $\rho = 0$. To do this, we show that the same element ρ can also be written as a sum of $k - 1$ products.

Suppose that $\rho(x, y) = 0$. If $a_k = 0$, then $\rho = \sum_{i=1}^{k-1} a_i b_i$. If $a_k \neq 0$, the function defined by a_k isn't identically zero on X . We choose a point \bar{x} of X such that $a_k(\bar{x}) \neq 0$. Let $\bar{a}_i = a_i(\bar{x})$ and $\rho(y) = \rho(\bar{x}, y)$. So $\rho(y) = \sum_{i=1}^k \bar{a}_i b_i$. Since ρ vanishes on $X \times Y$, ρ vanishes on Y , and therefore $\rho = 0$. Since $\bar{a}_k \neq 0$, we can solve for b_k in the equation $\sum_{i=1}^k \bar{a}_i b_i = 0$: $b_k = \sum_{i=1}^{k-1} c_i b_i$, where $c_i = -\bar{a}_i/\bar{a}_k$. Substituting into ρ gives us an expression for ρ as a sum of $k - 1$ terms. Finally, when $k = 1$, $\rho = a_1 b_1$, and $\bar{a}_1 b_1 = 0$. Then $b_1 = 0$, and therefore $\rho = 0$. \square

zartoprod (3.3.6) the Zariski topology on $\mathbb{P}^m \times \mathbb{P}^n$

As mentioned above (3.1.10), the product of projective spaces $\mathbb{P}^m \times \mathbb{P}^n$ is made into a projective variety by identifying it with its Segre image, the locus of the Segre equations $w_{ij}w_{k\ell} = w_{i\ell}w_{kj}$. Since $\mathbb{P}^m \times \mathbb{P}^n$, with its Segre embedding, is a projective variety, we don't really need a separate definition of its Zariski topology. Its closed subsets are the zero sets of families of homogeneous polynomials in the Segre variables w_{ij} (equations that include the Segre equations.)

One can also describe the closed subsets of $\mathbb{P}^m \times \mathbb{P}^n$ directly, in terms of bihomogeneous polynomials. A polynomial $f(x, y)$ is *bihomogeneous* if it is homogeneous in the variables x and also in the variables y . For example, the polynomial $x_0^2 y_0 + x_0 x_1 y_1$ is bihomogeneous, of degree 2 in x and degree 1 in y .

Because (x, y) and $(\lambda x, \mu y)$ represent the same point of $\mathbb{P}^m \times \mathbb{P}^n$ for all nonzero λ and μ , we want to know that $f(x, y) = 0$ if and only if $f(\lambda x, \mu y) = 0$. This is true for all nonzero λ and μ if and only if f is bihomogeneous.

PxPtopology **3.3.7. Lemma.** *The (Zariski) topology on $\mathbb{P}^m \times \mathbb{P}^n$ has the properties listed in Proposition 3.3.1:*

- *The projections $\mathbb{P}^m \times \mathbb{P}^n \rightarrow \mathbb{P}^m$ and $\mathbb{P}^m \times \mathbb{P}^n \rightarrow \mathbb{P}^n$ are continuous maps.*
- *For all y in \mathbb{P}^n , the fibre $\mathbb{P}^m \times y$, with the topology induced from $\mathbb{P}^m \times \mathbb{P}^n$, is homeomorphic to \mathbb{P}^m , and the analogous statement is true for the fibre $x \times \mathbb{P}^n$.*

proof. We look at the projection $\mathbb{P}^m \times \mathbb{P}^n \rightarrow \mathbb{P}^m$. If X is the closed subset of \mathbb{P}^m defined by a system of homogeneous polynomials $f_i(x)$, its inverse image in $\mathbb{P}^m \times \mathbb{P}^n$ is the zero set of the same system, considered as a family of bihomogeneous polynomials of degree zero in y . So the inverse image is closed.

For the second property, because the projection $\mathbb{P}^m \times \mathbb{P}^n \rightarrow \mathbb{P}^m$ is continuous, it suffices to show that the inclusion map $\mathbb{P}^m \rightarrow \mathbb{P}^m \times \mathbb{P}^n$ that sends \mathbb{P}^m to $\mathbb{P}^m \times y$ is continuous. If $f(x, y)$ is a bihomogeneous polynomial and \bar{y} is a point of \mathbb{P}^n , the zero set of f in $\mathbb{P}^m \times \bar{y}$ is the zero set of $f(x, \bar{y})$. This polynomial also defines a closed subset of \mathbb{P}^m . \square

3.3.8. Proposition.

(i) *The Segre image of a subset S of $\mathbb{P}^m \times \mathbb{P}^n$ is closed if and only if S is the locus of zeros of a family of bihomogeneous polynomials.*

(ii) *If X and Y are closed subsets of \mathbb{P}^m and \mathbb{P}^n , respectively, then $X \times Y$ is a closed subset of $\mathbb{P}^m \times \mathbb{P}^n$.*

proof. (i) For this proof, we denote the Segre image of $\mathbb{P}^m \times \mathbb{P}^n$ by Π . Let $f(w)$ be a homogeneous polynomial in the Segre variables w_{ij} . When we substitute $w_{ij} = x_i y_j$ into f , we obtain a polynomial $f(x_i y_j)$ that is bihomogeneous and that has the same degree as f in x and in y . Let's denote that bihomogeneous polynomial by $\tilde{f}(x, y)$. The inverse image of the zero set of f in Π is the zero set of \tilde{f} in $\mathbb{P}^m \times \mathbb{P}^n$. Therefore the inverse image of a closed subset of Π is the zero set of a family of bihomogeneous polynomials in $\mathbb{P}^m \times \mathbb{P}^n$.

Conversely, let $\tilde{g}(x, y)$ be a bihomogeneous polynomial, say of degrees r in x and degree s in y . If $r = s$, we may collect variables that appear in \tilde{g} in pairs $x_i y_j$ and replace each pair $x_i y_j$ by w_{ij} . We will obtain a homogeneous polynomial g in w such that $g(w) = \tilde{g}(x, y)$ when $w_{ij} = x_i y_j$. The zero set of g in Π is the image of the zero set of \tilde{g} in $\mathbb{P}^m \times \mathbb{P}^n$.

Suppose that $r \geq s$, and let $k = r - s$. Because the variables y cannot all be zero at any point of \mathbb{P}^n , the equation $g = 0$ on $\mathbb{P}^m \times \mathbb{P}^n$ is equivalent with the system of equations $gy_0^k = gy_1^k = \dots = gy_n^k = 0$. The polynomials gy_i^k are bihomogeneous, of same degree in x and in y . This puts us back in the first case.

(ii) A polynomial $f(x)$ can be viewed as a bihomogeneous polynomial of degree zero in y , and a polynomial $g(y)$ as a bihomogeneous polynomial of degree zero in x . So $X \times Y$, which is the locus $f = g = 0$ in $\mathbb{P}^m \times \mathbb{P}^n$, is closed in $\mathbb{P}^m \times \mathbb{P}^n$. \square

3.3.9. Corollary. *Let X and Y be projective varieties, and let Π denote the product $X \times Y$, which is a closed subset of $\mathbb{P}^m \times \mathbb{P}^n$.*

- *The projections $\Pi \rightarrow X$ and $\Pi \rightarrow Y$ are continuous.*
- *For all x in X and all y in Y , the fibres $x \times Y$ and $X \times y$, with topologies induced from Π , are homeomorphic to Y and X , respectively.*

Therefore the product $X \times Y$ is a projective variety. \square

We will come back to products in Chapter 5.

3.4 Rational Functions

(3.4.1) the function field

To construct the function field of a projective variety X , one can choose an arbitrary affine open subset $U = \text{Spec } A$. The function field of X will be the field of fractions of the coordinate algebra A . Since the only affine open subsets of X that we know are the intersections with the standard affine open sets of projective space, we will use those. The general definition of affine open sets is still to come (see 3.6).

Say that X is a closed subvariety of \mathbb{P}^n , and let x_0, \dots, x_n be coordinates in \mathbb{P}^n . For each $i = 0, \dots, n$, let X^i be the intersection of X with the standard affine open subset \mathbb{U}^i . If X^i is nonempty, it will be an affine variety – a closed subvariety of \mathbb{U}^i . Let's omit the indices for which X^i is empty. Then the intersection $X^{ij} = X^i \cap X^j$ will be a localization of X^i and also a localization of X^j . If $X^i = \text{Spec } A_i$, where A_i the algebra is generated by the images of the elements $u_{ij} = x_j/x_i$ in A_i , then if we denote the restrictions by u_{ij} too, $X^{ij} = \text{Spec } A_{ij}$, where $A_{ij} = A_i[u_{ij}^{-1}] = A_j[u_{ji}^{-1}]$.

We'll call the subsets $X^i = X \cap \mathbb{U}^i$ that aren't empty the *standard open subsets* of X .

closedin-
pXP

projcont

ratfnsec
fnfld

deffnfld

3.4.2. Definition. The *function field* K of a projective variety X is the field of fractions of the coordinate algebra A_i of any one of the standard open subsets X^i . A *rational function* on X is an element of its function field K .

Let p be a point of X that lies in the standard open set $X^i = \text{Spec } A_i$, as above. A rational function α on X is *regular* at p if it can be written as a fraction a/b of elements of A_i , with $b(p) \neq 0$. If α is regular at p , the *value* of α at p is $\alpha(p) = a(p)/b(p)$.

Thus a rational function α on X can be evaluated at some points of X , usually not at all of them. It will define a function on a nonempty open subset of X .

When X' is an open subvariety of a projective variety X , the *function field* of X' is defined to be the function field of X . Thus all open subvarieties of a variety have the same function field. A rational function on X' is a rational function on X , and a rational function is regular at a point p of X' if it is a regular rational function on X .

regindep

3.4.3. Lemma. *Let p be a point of a projective variety X . The regularity of a rational function at p doesn't depend on the choice of a standard open set X^i that contains p .* \square

When we regard an affine variety $X = \text{Spec } A$ as a closed subvariety of \mathbb{U}^0 , its function field will be the field of fractions of A , and a rational function α on X will be *regular* at a point p of X if it can be written as a fraction $\alpha = a/s$, where a and s are in A and s isn't zero at p . Thus α is regular at p if it is an element of the coordinate algebra of some localization X_s that contains p . Proposition 2.7.2 shows, as expected, that the regular functions on an affine variety $\text{Spec } A$ are the elements of A .

3.4.4. Lemma. *Let X be a projective variety. A rational function that is regular on a nonempty open set X' is determined by the function it defines on X' .*

proof. We show that if the function defined by an element α is identically zero on X' , then α is zero.

We replace X by one of its standard open sets $X^i = \text{Spec } A_i$, and X' by localization of X^i that is a subset of $X' \cap X^i$. Then X will be affine and X' will be a localization $X_s = \text{Spec } A_s^i$. Let $A = A_s^i$. It suffices to prove that an element α of A that defines the zero function on $\text{Spec } A$ is zero. Or, equivalently, that the only element of A which is in every maximal ideal of A is zero. This is Corollary 2.5.15 (ii). \square

ptvlfld

(3.4.5) points with values in a field

Let K be a field that contains the complex numbers. A *point* of projective space \mathbb{P}^n with values in K is an equivalence class of nonzero vectors $\alpha = (\alpha_0, \dots, \alpha_n)$ with α_i in K , the equivalence relation being analogous to the one for ordinary points: $\alpha \sim \alpha'$ if $\alpha' = \lambda\alpha$ for some λ in K .

If K is the function field of a variety X , the embedding of X into projective space \mathbb{P}^n defines a point $(\alpha_0, \dots, \alpha_n)$ of X with values in K . To get this point, one may choose a standard affine open set, say \mathbb{U}^0 , of \mathbb{P}^m such that $X^0 = X \cap \mathbb{U}^0$ isn't empty. Then X^0 is affine, say $X^0 = \text{Spec } A_0$. The embedding of X^0 into the affine space \mathbb{U}^0 is defined by a homomorphism $\mathbb{C}[u_1, \dots, u_n] \rightarrow A_0$, $u_i = x_i/x_0$. If α_i denotes the image in A_0 of u_i for $i = 1, \dots, n$, and $\alpha_0 = 1$, then $(\alpha_0, \alpha_1, \dots, \alpha_n)$ is a point of \mathbb{P}^n with values in K . This is the point with values in K that is determined by the embedding of X .

ffofprod

(3.4.6) the function field of a product

To define the function field of the product $X \times Y$ of projective varieties, we can use the Segre embedding $\mathbb{P}_x^m \times \mathbb{P}_y^n \rightarrow \mathbb{P}_w^N$. Let Π denote the Segre image of $X \times Y$ in \mathbb{P}^N . We use notation that was established in (3.1.10). The coordinates in the three projective spaces \mathbb{P}^m , \mathbb{P}^n , and \mathbb{P}^N are x_i , y_j , and w_{ij} , respectively, and the Segre map is defined by $w_{ij} = x_i y_j$. Let \mathbb{U}^i , \mathbb{V}^j , and \mathbb{W}^{ij} be the standard affine open sets in the three projective spaces, and let $X^i = X \cap \mathbb{U}^i$, $Y^j = Y \cap \mathbb{V}^j$, and $\Pi^{-j} \Pi \cap \mathbb{W}^{ij}$. The product $X^i \times Y^j$ maps bijectively to Π^{ij} , and the function field of Π will be the field of fractions of any of the nonempty intersections Π^{ij} .

Since $\Pi^{ij} = X^i \times Y^j$, all that remains to do is to describe the field of fractions of a product Π of affine varieties $X \times Y$, when $X = \text{Spec } A$ and $Y = \text{Spec } B$. If $A = \mathbb{C}[x]/P$ and $B = \mathbb{C}[y]/Q$, and if P' and Q' are the ideals of $\mathbb{C}[x, y]$ generated by P and Q , respectively, then

the coordinate algebra of Π is the algebra $\mathbb{C}[x, y]/(P' + Q')$ (see Proposition 3.3.4). This algebra is the tensor product algebra $A \otimes B$. We don't need to know much about the tensor product algebra here, but let's use the tensor notation.

The function field K_X of X is the field of fractions of A . Similarly, K_Y is the field of fractions of B and $K_{X \times Y}$ is the field of fractions of $A \otimes B$. The one fact to note is that $K_{X \times Y}$ isn't generated by K_X and K_Y . For example, if $A = \mathbb{C}[x]$ and $B = \mathbb{C}[y]$ (one x and one y), then $K_{X \times Y}$ is the field of rational functions in two variables $\mathbb{C}(x, y)$. The algebra generated by the fraction fields $\mathbb{C}(x)$ and $\mathbb{C}(y)$ consists of the rational functions $p(x, y)/q(x, y)$ in which $q(x, y)$ is a product $f(x)g(y)$ of a polynomial in x and a polynomial in y . Most rational functions, $1/(x + y)$ for example, aren't of this type.

But, $K_{X \times Y}$ is the fraction field of $A \otimes B$. The denominator can be any nonzero element of $A \otimes B$

(3.4.7) interlude: rational functions on projective space

ratfn-
spspace

Let R denote the polynomial ring $\mathbb{C}[x_0, \dots, x_n]$. A homogeneous polynomial f of positive degree d doesn't define a function on \mathbb{P}^n , because $f(\lambda x) = \lambda^d f(x)$. It does make sense to say that f vanishes at a point of \mathbb{P}^n .

On the other hand, a fraction g/h of homogeneous polynomials of the same degree d does define a function wherever h isn't zero, because

$$g(\lambda x)/h(\lambda x) = \lambda^d g(x)/\lambda^d h(x) = g(x)/h(x)$$

A homogeneous fraction f is a fraction of homogeneous polynomials. The degree of a homogeneous fraction $f = g/h$ is the difference of degrees: $\deg f = \deg g - \deg h$.

A homogeneous fraction f is regular at a point p of \mathbb{P}^n if, when it is written as a fraction g/h of relatively prime homogeneous polynomials, the denominator h isn't zero at p , and f is regular on a subset U if it is regular at every point of U . This definition agrees with the one given above, in Definition 3.4.2.

3.4.8. Lemma. (i) Let h be a homogeneous polynomial of positive degree d , and let V be the open subset of \mathbb{P}^n of points at which h isn't zero. The nonzero rational functions that are regular on V are those of the form g/h^k , where $k \geq 0$ and g is a homogeneous polynomial of degree dk .

ho-
mogfractsfn-
fld

(ii) The only rational functions that are regular at every point of \mathbb{P}^n are the constant functions.

For example, the homogeneous polynomials that don't vanish at any point of the standard affine open set \mathbb{U}^0 are the scalar multiples of powers of x_0 . So the rational functions that are regular on \mathbb{U}^0 are those of the form g/x_0^k , g homogeneous of degree k . This agrees with the fact that the coordinate algebra of \mathbb{U}^0 is the polynomial ring $\mathbb{C}[u_1, \dots, u_n]$, with $u_i = x_i/x_0$, because $g(x_0, \dots, x_n)/x_0^k = g(u_0, \dots, u_n)$.

proof of Lemma 3.4.8. (i) Let α be a regular function on the open set U , say $\alpha = g_1/h_1$, where g_1 and h_1 are relatively prime homogeneous polynomials. Then h_1 doesn't vanish on U , so its zero locus in \mathbb{P}^n is contained in the zero locus of h . According to the Strong Nullstellensatz 3.2.8, h_1 divides a power of h , say $h^k = fh_1$. Then $g_1/h_1 = fg_1/fh_1 = fg_1/h^k$.

(ii) If a rational function f is regular at every point of \mathbb{P}^n , then it is regular on \mathbb{U}^0 . so it will have the form g/x_0^k , where g is a homogeneous polynomial of degree k that isn't divisible by x_0 . And since f is also regular on \mathbb{U}^1 , it will have the form h/x_1^ℓ , where h is homogeneous and not divisible by x_1 . Then $gx_1^\ell = hx_0^k$. Since x_0 doesn't divide g , $k = 0$, g is a constant, and $f = g$. \square

It is also true that the only rational functions on a projective variety X that are regular at every point are the constant functions. The proof of this will be given later (see Corollary 8.3.10). When studying projective varieties, the constant functions are useless, so one has to look at regular functions on open subsets. One way that affine varieties appear in projective algebraic geometry is as open subsets on which there are enough regular functions.

3.5 Morphisms and Isomorphisms

Some morphisms, such as the projection from a product variety $X \times Y$ to X , are sufficiently obvious that they don't really require any discussion. But most morphisms are not obvious.

sectmorph

Let X and Y be varieties, and suppose that X and Y are subvarieties of the projective space \mathbb{P}^m and \mathbb{P}^n , respectively. A morphism $Y \rightarrow X$ will be determined by a morphism $Y \xrightarrow{f} \mathbb{P}^m$ whose image is contained in X . However, a morphism from Y to \mathbb{P}^m needn't be the restriction of a morphism from \mathbb{P}^n to \mathbb{P}^m . Most often, there will be no way to extend f to \mathbb{P}^n . This means that it is usually impossible to define f using polynomials in the coordinate variables of \mathbb{P}^n .

For example, the Veronese map from the projective line \mathbb{P}^1 to \mathbb{P}^2 , defined by $(x_0, x_1) \rightsquigarrow (x_0^2, x_0x_1, x_1^2)$, is an obvious morphism. Its image is the conic $C : v_{00}v_{11} - v_{01}^2 = 0$ in the projective plane \mathbb{P}^2 . The Veronese defines a bijective morphism $\mathbb{P}^1 \xrightarrow{f} C$ whose inverse function sends a point (v_{00}, v_{01}, v_{11}) of C with $v_{00} \neq 0$ to the point $(x_0, x_1) = (v_{01}, v_{11})$. There is no way to extend this inverse function f^{-1} to \mathbb{P}^2 , though it is a morphism. In fact, the only morphisms from \mathbb{P}^2 to \mathbb{P}^1 are the constant morphisms whose images are points.

We define morphisms using points with values in a field.

morphP (3.5.1) **morphisms to projective space**

Let K be the function field of a variety X . For the rest of this section, it will be helpful to have a separate notation for the point with values K that is determined by a nonzero vector $\alpha = (\alpha_0, \dots, \alpha_n)$, with entries in K . We'll denote that point by $\underline{\alpha}$. So $\underline{\alpha} = \underline{\alpha}'$ if $\alpha' = \lambda\alpha$ for some nonzero λ in K . We'll drop this notation later.

We define a morphism from a variety X to projective space \mathbb{P}^n using a point of \mathbb{P}^n with values in the function field K of X . When doing this, we must keep in mind that points of projective space are equivalence classes of vectors, not the vectors themselves. As we will see, this complication turns out to be useful.

We begin with a simple example.

project- conic 3.5.2. **Example.** Let C be the conic in the projective plane \mathbb{P}^2 defined by $f(x_0, x_1, x_2) = x_0x_1 + x_0x_2 + x_1x_2$. We project C to the line $L_0 : \{x_0 = 0\}$, defining $C \xrightarrow{\pi} \mathbb{P}^1$ by $\pi(x_0, x_1, x_2) = (x_1, x_2)$. The formula for π is undefined at the point $q = (1, 0, 0)$, though the map extends to the whole conic C .

Let's write this projection using a point with values in the function field K of C . The affine open set $\{x_0 \neq 0\}$ of \mathbb{P}^2 is the polynomial algebra $\mathbb{C}[u_1, u_2]$, with $u_1 = x_1/x_0$ and $u_2 = x_2/x_0$. We also denote by u_i the restriction of the function u_i to $C^0 = C \cap \mathbb{U}^0$. The restricted functions are related by the equation $u_1 + u_2 + u_1u_2 = 0$ that is obtained by dehomogenizing f . We solve for u_2 : $u_2 = -u_1/(1 + u_1)$.

The projection is given by $\pi(x_0, x_1, x_2) = \pi(1, u_1, u_2) = (u_1, -u_1/(1 + u_1))$. Multiplying by $\lambda = (1 + u_1)/u_1$, we see that $\pi(x_0, x_1, x_2)$ is the point $(1 + u_1, -1)$, which is a point with values in the function field of C , and it defines the maps at all points of C at which $x_0 \neq 0$, including q . Thus $\pi(q) = (1, -1)$. As an exercise, you should verify that the image of q is the point at which the tangent line L_q to C at q intersects L_0 .

To define π at the remaining points, we look on another standard affine open set. Let $v_i = x_i/x_1$ and $w_i = x_i/x_2$. Then $(x_0, x_1, x_2) = (v_0, 1, v_2) = (w_0, w_1, 1)$. The projection can also be written as $\pi(x) = (1, v_2)$, which is valid at points at which $x_1 \neq 0$ or as $\pi(x) = (w_1, 1)$, which is valid at points at which $x_2 \neq 0$. \square

Let K be the function field of a variety Y , and let $\alpha = (\alpha_0, \dots, \alpha_n)$ be a nonzero vector with entries in K . We try to define a morphism from Y to projective space \mathbb{P}^n using the point $\underline{\alpha}$ with values in K that is determined by α . To define the image of a point q of Y (an ordinary point), we look for a vector $\alpha' = (\alpha'_0, \dots, \alpha'_n)$, with $\underline{\alpha}' = \underline{\alpha}$, (i.e., $\alpha' = \lambda\alpha$ with λ in K), such that the rational functions α'_i are regular at q and not all zero there. Such a vector may exist or not. If it exists, we define

defmor- phP (3.5.3)
$$\underline{\alpha}(q) = (\alpha'_0(q), \dots, \alpha'_n(q)) \quad (= \underline{\alpha}'(q))$$

If α is given, and if such a vector α' exists for every point q of Y , we call $\underline{\alpha}$ a *good point*.

twoconds 3.5.4. **Lemma.** A point $\underline{\alpha}$ of \mathbb{P}^n with values in the function field K_Y of Y is a good point if either one of the two following conditions holds for every point q of Y :

- There is an element λ of K_Y such that the rational functions $\alpha'_i = \lambda\alpha_i$, $i = 0, \dots, n$, are all regular and not all zero at q .
- There is an index j such that the rational functions α_i/α_j are regular at q , for $i = 0, \dots, n$.

proof. The first condition simply restates the definition. We show that it is equivalent with the second one.

Suppose that α_i/α_j are regular at q for all i . Let $\lambda = \alpha_j^{-1}$, and let $\alpha'_i = \lambda\alpha_i = \alpha_i/\alpha_j$. The rational functions α'_i are regular at q , and they aren't all zero there because $\alpha'_j = 1$.

Conversely, suppose that $\alpha'_i = \lambda\alpha_i$ are all regular at q and that α'_j isn't zero there. Then α'_j^{-1} is a regular function at q , so the rational functions α'_i/α'_j , which are equal to α_i/α_j , are regular at q for all i . \square

3.5.5. Lemma. *With notation as in (3.5.3), the image $\underline{\alpha}(q)$ in \mathbb{P}^n of a point q is independent of the choice of the vector α' .*

doesntdepend

proof. Say that $\alpha'_i = \lambda\alpha_i$ are regular at q for all i , and that $\alpha'_j(q) \neq 0$. Then by definition, $\underline{\alpha}(q) = \underline{\alpha}'(q)$. Let $\alpha''_i = \alpha'_i/\alpha'_j = \alpha_i/\alpha_j$. Then $\alpha''_j = 1$, α'' is independent of λ , and $\underline{\alpha}'(q) = \underline{\alpha}(q) = \underline{\alpha}''(q)$. \square

3.5.6. Definition. Let Y be a variety with function field K . A *morphism* from Y to projective space \mathbb{P}^n is a map that is defined, as in (3.5.3) above, by a good point $\underline{\alpha}$ with values in K . We may denote the morphism defined by a good point $\underline{\alpha}$ by $\underline{\alpha}$ too.

defmorphoP

3.5.7. Example. *The identity map $\mathbb{P}^1 \rightarrow \mathbb{P}^1$.*

identmap

Let $X = \mathbb{P}^1$, and let (x_0, x_1) be coordinates in X . The function field of X is the field $K = \mathbb{C}(t)$ of rational functions in the variable $t = x_1/x_0$. The identity map $X \rightarrow X$ is the map $\underline{\alpha}$ defined by the point $\alpha = (1, t)$ with values in K . For every point p of X except the point $(0, 1)$, $\underline{\alpha}(p) = \alpha(p) = (1, t(p))$. For the point $q = (0, 1)$, we let $\alpha' = t^{-1}\alpha = (t^{-1}, 1)$. Then $\underline{\alpha}(q) = \alpha'(q) = (x_0(q)/x_1(q), 1) = (0, 1)$. \square

(3.5.8) morphisms to quasiprojective varieties

morphoV

3.5.9. Definition. Let Y be a variety, and let X be a subvariety of a projective space \mathbb{P}^n . A morphism of varieties $Y \xrightarrow{\underline{\alpha}} X$ is the restriction of a morphism $Y \xrightarrow{\underline{\alpha}} \mathbb{P}^n$ whose image is contained in X .

defmorphoX

3.5.10. Lemma. *When a projective variety X is the locus of zeros of a family f of homogeneous polynomials, a morphism $Y \xrightarrow{\underline{\alpha}} \mathbb{P}^n$ defines a morphism $Y \rightarrow X$ if and only if $f(\alpha) = 0$.* \square

ptfvalKfzero

A word of caution: A morphism $Y \xrightarrow{\underline{\alpha}} X$ won't define a map of function fields $K_X \rightarrow K_Y$ unless the image of Y is dense in X .

3.5.11. Proposition. *A morphism of varieties $Y \xrightarrow{\underline{\alpha}} X$ is a continuous map in the Zariski topology, and also a continuous map in the classical topology.*

morphcont

proof. This proposition follows from the previous work, once one has unraveled the notation. Let \mathbb{U}^i be the standard affine open subset of \mathbb{P}^m , and let Y^i be an affine open subset of the inverse image of \mathbb{U}^i . If $X = \mathbb{P}^m$, the restriction $Y^i \rightarrow \mathbb{U}^i$ of $\underline{\alpha}$ is continuous in either topology because it is a morphism of affine varieties, as was defined in Section 2.7. Since Y can be covered by affine open sets such as Y^i , $\underline{\alpha}$ is continuous. Continuity for a morphism to a subvariety X of \mathbb{P}^m follows, because the topology on X is the induced topology. \square

3.5.12. Proposition. *Let X, Y , and Z be varieties and let $Z \xrightarrow{\underline{\beta}} Y$ and $Y \xrightarrow{\underline{\alpha}} X$ be morphisms. The composed map $Z \xrightarrow{\underline{\alpha\beta}} X$ is a morphism.*

compmorph

proof. The proof is easy. We'll spell it out, perhaps in too much detail. Say that X is a subvariety of \mathbb{P}^m . The morphism α is the restriction of a morphism $Y \rightarrow \mathbb{P}^m$ whose image is in X , and that is defined by a good point $\underline{\alpha}$, $\alpha = (\alpha_0, \dots, \alpha_m)$ of \mathbb{P}^m with values in the function field K_Y of Y . Similarly, if Y is a subvariety of \mathbb{P}^n , the morphism β is the restriction of a morphism $Z \rightarrow \mathbb{P}^n$ whose image is contained in Y , and that is defined by a good point $\underline{\beta}$, $\beta = (\beta_0, \dots, \beta_n)$ of \mathbb{P}^n with values in the function field K_Z of Z .

Let z be an ordinary point of Z . Since $\underline{\beta}$ is a good point, we may adjust β by a factor in K_Z so that the rational functions β_i are regular and not all zero at z . Then $\underline{\beta}(z)$ is the point $(\beta_0(z), \dots, \beta_n(z))$. Let's denote that point by $q = (q_0, \dots, q_n)$, where $q_i = \beta_i(z)$. The elements α_j are rational functions on Y . Since α is a good point, we may adjust by a factor in K_Y , so that α_i they are all regular and not all zero at q . Then $[\underline{\alpha\beta}](z) = \underline{\alpha}(q) = (\alpha_0(q), \dots, \alpha_m(q))$, and $\alpha_j(q) = \alpha_j(\beta_0(z), \dots, \beta_n(z)) = \alpha_j(\beta(z))$ are not all zero. When these adjustments have been made, the point of \mathbb{P}^m with values in K_Z that defines $\underline{\alpha\beta}$ is $(\alpha_0(\beta(z)), \dots, \alpha_m(\beta(z)))$. \square

This next result is a lemma of topology.

closed-
naff

3.5.13. Lemma. *Let $\{X^i\}$ be a covering of a topological space X by open sets. A subset Y of X is open (or closed) if and only if $Y \cap X^i$ is open (or closed) in X^i for every i . In particular, if $\{\mathbb{U}^i\}$ is the standard affine cover of \mathbb{P}^n , a subset Y of \mathbb{P}^n is open (or closed) if and only if $Y \cap \mathbb{U}^i$ is open (or closed) in \mathbb{U}^i for every i . \square*

firstprop-
morph

3.5.14. Lemma.

(i) *The inclusion of an open or a closed subvariety Y into a variety X is a morphism.*

(ii) *Let $Y \xrightarrow{f} X$ be a map whose image lies in an open or a closed subvariety Z of X . Then f is a morphism if and only if its restriction $Y \rightarrow Z$ is a morphism.*

(iii) *Let $\{Y^i\}$ be an open covering of a variety Y , and let $Y^i \xrightarrow{f^i} X$ be morphisms. If the restrictions of f^i and f^j to the intersections $Y^i \cap Y^j$ are equal for all i, j , there is a unique morphism f whose restriction to Y^i is f^i .*

Part (iii) is true because the points with values in K that define the morphisms f^i are all equal. We omit the proofs of (i) and (ii). \square

isomor-
phisms

(3.5.15) isomorphisms

A bijective morphism $Y \xrightarrow{u} X$ of quasiprojective varieties whose inverse function is also a morphism is an *isomorphism*. Isomorphisms are important because they allow us to identify different incarnations of the “same” variety, i.e., to describe an isomorphism class of varieties. For example, the projective line \mathbb{P}^1 , a conic in \mathbb{P}^2 , and the twisted cubic in \mathbb{P}^3 are isomorphic.

twistcu-
bicinverse

3.5.16. Example.

Let Y denote the projective line, with coordinates y_0, y_1 . As before, the function field of Y is the field $K = \mathbb{C}(t)$ of rational functions in $t = y_1/y_0$. The degree 3 Veronese map $Y \rightarrow \mathbb{P}^3$ (3.1.16) defines an isomorphism of Y to its image, a twisted cubic X . The Veronese map is defined by the point $\alpha = (1, t, t^2, t^3)$ of \mathbb{P}^3 with values in K . On the open set $\{y_0 \neq 0\}$ of Y , the rational functions $1, t, t^2, t^3$ are regular and not all zero. Let $\lambda = t^{-3}$ and $\alpha' = \lambda\alpha = (t^{-3}, t^{-2}, t^{-1}, 1)$. The functions t^{-k} are regular on the open set $\{y_1 \neq 0\}$. So α is a good point that defines a morphism $Y \xrightarrow{\alpha} X$.

The twisted cubic X is the locus of zeros of the equations (3.1.17):

$$v_0v_2 = v_1^2, \quad v_2v_1 = v_0v_3, \quad v_1v_3 = v_2^2$$

To identify the function field F of X , we put $v_0 = 1$, obtaining relations $v_2 = v_1^2, v_3 = v_1^3$. Then F is the field $\mathbb{C}(v_1)$. The point of $Y = \mathbb{P}^1$ with values in F that defines the inverse of the morphism $\underline{\alpha}$ is $\beta = (1, v_1)$. \square

propisom

3.5.17. Lemma. *Let $Y \xrightarrow{f} X$ be a morphism of varieties, let $\{X^i\}$ and $\{Y^i\}$ be open coverings of X and Y , respectively, such that the image of Y^i in X is contained in X^i . If the restrictions $Y^i \xrightarrow{f^i} X^i$ of f are isomorphisms, then f is an isomorphism.*

proof. Let g^i denote the inverse of the morphism f^i . Then $g^i = g^j$ on $X^i \cap X^j$ because $f^i = f^j$ on $Y^i \cap Y^j$. By (3.5.14) (iii), there is a unique morphism $X \xrightarrow{g} Y$ whose restriction to Y^i is g^i . That morphism is the inverse of f . \square

diagonal

(3.5.18) the diagonal

Let X be a variety. In $X \times X$, the *diagonal*, X_Δ , the set of points (p, p) . It is an example of a subset of $X \times X$ that is closed in the Zariski topology, but not closed in the product topology.

3.5.19. Proposition. *Let X be a variety. The diagonal X_Δ is a closed subvariety of the product variety $X \times X$.* diagclosed

proof. Let \mathbb{P} denote the projective space \mathbb{P}^n that contains X , and let x_0, \dots, x_n and y_0, \dots, y_n be coordinates in the two factors of $\mathbb{P} \times \mathbb{P}$. The diagonal \mathbb{P}_Δ in $\mathbb{P} \times \mathbb{P}$ is the closed subvariety defined by the bilinear equations $x_i y_j = x_j y_i$, or in the Segre variables, by the equations $w_{ij} = w_{ji}$, which show that the ratios x_i/x_j and y_i/y_j are equal.

Next, suppose that X is the closed subvariety of \mathbb{P} defined by a system of homogeneous equations $f(x) = 0$. The diagonal X_Δ can be identified as the intersection of the product $X \times X$ with the diagonal \mathbb{P}_Δ in $\mathbb{P} \times \mathbb{P}$, so it is a closed subvariety of $X \times X$. As a closed subvariety of $\mathbb{P} \times \mathbb{P}$, the diagonal X_Δ is defined by the equations

$$(3.5.20) \quad x_i y_j = x_j y_i \quad \text{and} \quad f(x) = 0 \quad \text{Xdelta}$$

(See (3.5.14)(ii).) The equations $f(y) = 0$ are redundant.) The diagonal is irreducible because it is homeomorphic to X . □

It is interesting to compare Proposition 3.5.19 with the Hausdorff condition for a topological space. The proof of the next lemma is often assigned as an exercise in topology.

3.5.21. Lemma. *A topological space X is a Hausdorff space if and only if, when $X \times X$ is given the product topology, the diagonal X_Δ is a closed subset of $X \times X$.* hausdorff-diagonal □

Though a variety X with its Zariski topology isn't a Hausdorff space unless it is a point, Lemma 3.5.21 doesn't contradict Proposition 3.5.19 because the Zariski topology on $X \times X$ is finer than the product topology.

(3.5.22) the graph of a morphism ggraph

Let $Y \xrightarrow{f} X$ be a morphism of varieties. The *graph* Γ of f is the subset of $Y \times X$ of pairs (q, p) such that $p = f(q)$.

3.5.23. Proposition. *The graph Γ_f of a morphism $Y \xrightarrow{f} X$ is a closed subvariety of $Y \times X$, and it is isomorphic to Y .* graph

proof. We form a diagram of morphisms

$$(3.5.24) \quad \begin{array}{ccc} \Gamma_f & \longrightarrow & Y \times X \\ v \downarrow & & \downarrow f \times id \\ X_\Delta & \longrightarrow & X \times X \end{array} \quad \text{graphdiagram}$$

where v sends a point (q, p) of Γ_f with $f(q) = p$ to the point (p, p) of X_Δ . The graph is the inverse image in $Y \times X$ of the diagonal. Since the diagonal is closed in $X \times X$, Γ_f is closed in $Y \times X$.

Let π_1 denote the projection from $X \times Y$ to Y . The composition of the morphisms $Y \xrightarrow{(id, f)} Y \times X \xrightarrow{\pi_1} Y$ is the identity map on Y , and the image of the map (id, f) is the graph Γ_f . Therefore Y maps bijectively to Γ_f . The two maps $Y \rightarrow \Gamma_f$ and $\Gamma_f \rightarrow Y$ are inverses, so Γ_f is isomorphic to Y . □

(3.5.25) projection defprojection

The map

$$(3.5.26) \quad \mathbb{P}^n \xrightarrow{\pi} \mathbb{P}^{n-1} \quad \text{projectiontwo}$$

that drops the last coordinate of a point, i.e., $\pi(x_0, \dots, x_n) = (x_0, \dots, x_{n-1})$ is called a *projection*. (The projection from \mathbb{P}^2 to \mathbb{P}^1 was defined in Chapter 1.) The projection is defined at all points of \mathbb{P}^n except at the point $q = (0, \dots, 0, 1)$, which is called the *center of projection*. So π is really a morphism from the complement $U = \mathbb{P}^n - \{q\}$ to \mathbb{P}^{n-1} :

$$U \xrightarrow{\pi} \mathbb{P}^{n-1}$$

The points of U are those of the form $(x_0, \dots, x_{n-1}, 1)$

Let the coordinates in \mathbb{P}^n and \mathbb{P}^{n-1} be $x = x_0, \dots, x_n$ and $y = y_0, \dots, y_{n-1}$, respectively. The fibre $\pi^{-1}(y)$ over a point (y_0, \dots, y_{n-1}) is the set of points (x_0, \dots, x_n) such that $(x_0, \dots, x_{n-1}) = \lambda(y_0, \dots, y_{n-1})$, while x_n is arbitrary. It is the line in \mathbb{P}^n through the points $(y_1, \dots, y_{n-1}, 0)$ and $q = (0, \dots, 0, 1)$, with the center of projection q omitted.

In Segre coordinates, the graph Γ of π in $U \times \mathbb{P}^{n-1}$ is the locus of solutions of the equations $w_{ij} = w_{ji}$ for $0 \leq i, j \leq n-1$, which imply that the vectors (x_0, \dots, x_{n-1}) and (y_0, \dots, y_{n-1}) are proportional.

projgraph

3.5.27. Proposition. *The locus in $\mathbb{P}^n \times \mathbb{P}^{n-1}$ of the equations $x_i y_j = x_j y_i$, or $w_{ij} = w_{ji}$, with $0 \leq i, j \leq n-1$ is the closure $\bar{\Gamma}$ of the graph Γ of π .*

proof. The equations are true at points (x, y) of Γ at which $x \neq q$, and also at all points (q, y) . So the locus $\bar{\Gamma}$, a closed set, is the union of the graph Γ and the set $q \times \mathbb{P}^{n-1}$. We must show that a homogeneous polynomial $g(w)$ that vanishes on Γ vanishes at all points of $q \times \mathbb{P}^{n-1}$. Given (y_0, \dots, y_{n-1}) in \mathbb{P}^{n-1} , let $x = (ty_0, \dots, ty_{n-1}, 1)$. For all $t \neq 0$, the point (x, y) is in Γ and therefore $g(x, y) = 0$. Since g is a continuous function, $g(x, y)$ approaches $g(q, y)$ as $t \rightarrow 0$. So $g(q, y) = 0$. \square

The projection $\bar{\Gamma} \rightarrow \mathbb{P}^{n-1}$ that sends a point (x, y) to x is bijective except when $x = q$, and the fibre over q , which is $q \times \mathbb{P}^{n-1}$, is a projective space of dimension $n-1$. Because the point q of \mathbb{P}^n is replaced by a projective space in $\bar{\Gamma}$, the map $\bar{\Gamma} \rightarrow \mathbb{P}^n$ is called a *blowup* of the point q .

figure: projection with closure of graph??

productmap

3.5.28. Proposition. *Let $Y \xrightarrow{\alpha} X$ and $Z \xrightarrow{\beta} W$ be morphisms of varieties. The product map $Y \times Z \xrightarrow{\alpha \times \beta} X \times W$ that sends (y, z) to $(\alpha(y), \beta(z))$ is a morphism.*

proof. Let p and q be points of X and Y , respectively. We may assume that α_i are regular and not all zero at p and that β_j are regular and not all zero at q . Then, in the Segre coordinates w_{ij} , $[\alpha \times \beta](p, q)$ is the point $w_{ij} = \alpha_i(p)\beta_j(q)$. We must show that $\alpha_i\beta_j$ are all regular at (p, q) and are not all zero there, and this follows from the analogous properties of α_i and β_j . \square

3.6 Affine Varieties

affineV

We have used the term 'affine variety' in several contexts:

An irreducible closed subset of affine space \mathbb{A}^n is an affine variety, the set of zeros of a prime ideal P of $\mathbb{C}[x]$. The spectrum $\text{Spec } A$ of a finite type domain A is an affine variety. An affine variety becomes a variety in projective space when the ambient affine space \mathbb{A}^n is identified with the standard open subset \mathbb{U}^0 .

We combine these definitions now: An *affine variety* X is a variety that is isomorphic to a variety of the form $\text{Spec } A$.

If X is an affine variety with coordinate algebra A and function field K , then A will be the subalgebra of K whose elements are the regular functions on X . So A and $\text{Spec } A$, are determined uniquely by X , and the isomorphism $\text{Spec } A \rightarrow X$ is determined uniquely too. (If $\alpha_1, \dots, \alpha_n$ are algebra generators for A , then, when we regard X as a closed subvariety of the standard affine open set \mathbb{U}^0 of \mathbb{P}^n , the isomorphism $\text{Spec } A \rightarrow X$ is defined by the point $(1, \alpha_1, \dots, \alpha_n)$ with values in K .)

When a variety X is affine, it seems permissible to identify it with $\text{Spec } A$.

regfnon-affinetwo

(3.6.1) regular functions on affine varieties

Let $X = \text{Spec } A$ be an affine variety. Its function field K is the field of fractions of the coordinate algebra A . A rational function α is regular at a point p of X if it can be written as a fraction a/s where a, s are in A and $s(p) \neq 0$, and α is regular on X if it is regular at every point of X . As Proposition 2.7.2 shows, the regular functions on an affine variety $\text{Spec } A$ are the elements of A .

3.6.2. Lemma.

(i) Let R be the algebra of regular functions on a variety Y , and let A be a finite-type domain. A homomorphism $A \rightarrow R$ defines a morphism $Y \xrightarrow{f} \text{Spec } A$.

(ii) When X and Y are affine varieties, say $X = \text{Spec } A$ and $Y = \text{Spec } B$, morphisms $Y \rightarrow X$, as defined in (3.5.9), correspond bijectively to algebra homomorphisms $A \rightarrow B$, as in Definition 2.7.4.

Note. Since Y isn't affine, all that we know about the algebra R is that it is a subring of the function field of Y , and that its elements are the rational functions that are regular at every point of Y .

proof of Lemma 3.6.2. (i) Let $\{Y^i\}$ be an affine open covering of Y , and let R_i be the coordinate algebra of Y^i . The homomorphisms $A \rightarrow R \subset R_i$ define morphisms $Y^i = \text{Spec } R_i \xrightarrow{f^i} \text{Spec } A$ for each i . It is true that $f^i = f^j$ on $Y^i \cap Y^j$, so Lemma 3.5.14 (iii) applies here.

(ii) We choose a presentation of A , to embed X as a closed subvariety of affine space, and we identify that affine space with the standard affine open set \mathbb{U}^0 of \mathbb{P}^n . Let K be the function field of Y – the field of fractions of B . A morphism $Y \xrightarrow{u} X$ is determined by a good point α with values in K , for which $\alpha_0 \neq 0$. We may suppose that this point has the form $\alpha = (1, \alpha_1, \dots, \alpha_n)$. Then the rational functions α_i will be regular at every point of Y . They are elements of B . The coordinate algebra A of X is generated by the residues of the coordinate variables x_1, \dots, x_n , with $x_0 = 1$. Sending $x_i \rightarrow \alpha_i$ defines a homomorphism $A \xrightarrow{\varphi} B$. Conversely, if φ is such a homomorphism, the good point that defines the morphism $Y \xrightarrow{u} X$ is $(1, \varphi(x_1), \dots, \varphi(x_n))$. \square

3.6.3. Corollary. Let $Y \xrightarrow{f} X$ be a morphism of varieties, let q be a point of X , and let $p = f(q)$ be its image. If g is a regular function on X at p , then its pullback $g \circ f$ is a regular function on Y at q .

pullback-reg

proof. We choose an affine open neighborhood U of p in X , such that g is a regular function on U , and we choose an affine neighborhood V of q in Y that is contained in the inverse image $f^{-1}U$. The morphism f restricts to a morphism $V \rightarrow U$ that we may denote by the same letter f . Let A and B be the coordinate algebras of U and V , respectively. The morphism $V \xrightarrow{f} U$ corresponds to an algebra homomorphism $A \xrightarrow{\varphi} B$. On U , the function g is an element of A , and $g \circ f$ is the regular function $\varphi(g)$ in B (2.7.7). \square

(3.6.4) affine open subsets

affopens

Now that we have a definition of an affine variety, we can make the next definition. Though trivial, it is important.

An *affine open subset* of a variety X is an open subvariety that is an affine variety.

If V is a nonempty open subset of X and R is the algebra of regular functions that are regular on V , then V is an affine open subset if and only if R is a finite-type domain, so that $\text{Spec } R$ is defined, and V is isomorphic to $\text{Spec } R$.

3.6.5. Lemma. The affine open subsets of a variety X form a basis for the topology on X .

affinesbasis

proof. This follows from the fact that the localizations of an affine variety X form a basis for the topology on X . (See 2.6.)

A projective variety X is covered by the affine open sets $X^i = X \cap \mathbb{U}^i$. The localizations of these affine open sets are affine and they form a basis for the topology on X . Any variety X' is an open subvariety of a projective variety X , and the affine open subsets of X that are contained in X' form a basis for the topology on X' . \square

3.6.6. Proposition. The complement of a hypersurface is an affine open subvariety of \mathbb{P}^n .

comphyper

proof. Let H be the hypersurface defined by an irreducible homogeneous polynomial f of degree d , and let Y be the complement of H in \mathbb{P}^n . Also, let R and K be the algebra of regular functions and the field of rational functions on Y .

The elements of R are the homogeneous fractions of degree zero of the form g/f^k (3.4.7), and the fractions m/f , where m is a monomial of degree d , generate R . Since there are finitely many monomials of degree d ,

R is a finite-type domain. Lemma 3.6.2 gives us a morphism $Y \xrightarrow{u} X = \text{Spec } R$. We show that u is an isomorphism.

Let A be the algebra of regular functions on the standard affine open set \mathbb{U}^0 of \mathbb{P}^n . The intersection $Y^0 = Y \cap \mathbb{U}^0$ is a localization of \mathbb{U}^0 . It is $A[s^{-1}]$, where $s = f/x_0^d$. Let $t = s^{-1} = x_0^d/f$.

Yzero **3.6.7.** *The algebras $A[s^{-1}]$ and $R[t^{-1}]$ are equal.*

proof. The generators m/f of R can be written as products $s^{-1}(m/x_0^d)$. Since m/x_0^d is in A , the generators are in $A[s^{-1}]$. The generators x_i/x_0 of A can be written as $t^{-1}(m/x_0^d/f)$, where $m = x_i x_0^{d-1}$, so they are in $R[t^{-1}]$. \square

The lemma tells us that the morphism $Y \xrightarrow{u} X$ restricts to an isomorphism $Y^0 \rightarrow X^0 = \text{Spec } A[s^{-1}]$. Since the index 0 can be replaced by any $i = 0, \dots, n$, Lemma 3.5.17 shows that u is an isomorphism \square

*inter-
sectaffine*

3.6.8. Theorem. *Let U and V be affine open subvarieties of a variety X , say $U \approx \text{Spec } A$ and $V \approx \text{Spec } B$. The intersection $U \cap V$ is an affine open subvariety whose coordinate algebra is generated by the two algebras A and B .*

proof. We denote the algebra generated by two subalgebras A and B of the function field K of X by $[A, B]$. The elements of $[A, B]$ are finite sums of products of elements of A and B . If $A = \mathbb{C}[a_1, \dots, a_r]$, and $B = \mathbb{C}[b_1, \dots, b_s]$, then $[A, B]$ is generated by the set $\{a_i\} \cup \{b_j\}$.

Let $R = [A, B]$ and let $W = \text{Spec } R$. We are to show that W is isomorphic to $U \cap V$. The varieties U, V, W , and X have the same function field K . The inclusions of coordinate algebras $A \rightarrow R$ and $B \rightarrow R$ give us morphisms $W \rightarrow U$ and $W \rightarrow V$. We also have inclusions $U \subset X$ and $V \subset X$, and X is a subvariety of a projective space \mathbb{P}^n . Let α be the point of \mathbb{P}^n with values in K that defines the projective embedding $X \xrightarrow{\alpha_X} \mathbb{P}^n$. This point also defines morphisms $U \xrightarrow{\alpha_U} \mathbb{P}^n$, $V \xrightarrow{\alpha_V} \mathbb{P}^n$ and $W \xrightarrow{\alpha_W} \mathbb{P}^n$, where the morphisms α_U and α_V are the restrictions of α_X to the open subsets U and V , respectively.

The morphism $W \xrightarrow{\alpha_W} \mathbb{P}^n$ can be obtained as the composition of the morphisms $W \rightarrow U \subset X \xrightarrow{\alpha_X} \mathbb{P}^n$, and also as the analogous composition, in which V replaces U . Therefore the image of W in \mathbb{P}^n is contained in $U \cap V$. Thus α_W restricts to a morphism $W \xrightarrow{\epsilon} U \cap V$. We show that ϵ is an isomorphism.

Let p be a point of $U \cap V$. We choose an affine open subset Z of $U \cap V$ that is a localization of U and a localization of V , and that contains p (2.6.2)(ii),(iii). Let S be the coordinate ring of Z . So $S = A_s$ for some nonzero s in A and also $S = B_t$ for some nonzero t in B . Then

$$R_s = [A, B]_s = [A_s, B] = [S, B] = S$$

So ϵ maps the localization $W_s = \text{Spec } R_s$ of W isomorphically to the open subset Z of $U \cap V$ that contains p . Since we can cover $U \cap V$ by open sets such as Z , Lemma 3.5.14 (ii) shows that ϵ is an isomorphism. \square

3.7 Lines in Projective Three-Space

linesinp

The *Grassmanian* $G(m, n)$ is a variety whose points correspond to subspaces of dimension m of the vector space \mathbb{C}^n , and to linear subspaces of dimension $m-1$ of \mathbb{P}^{n-1} . One says that $G(m, n)$ *parametrizes* those subspaces. As a first example, the Grassmanian $G(1, n+1)$ is the projective space \mathbb{P}^n . Points of \mathbb{P}^n parametrize the one-dimensional subspaces of \mathbb{C}^{n+1} .

The Grassmanian $G(2, 4)$, which we denote by \mathbb{G} , parametrizes two-dimensional subspaces of \mathbb{C}^4 , or lines in \mathbb{P}^3 . We describe that Grassmanian in this section. The point of \mathbb{G} that corresponds to a line ℓ in \mathbb{P}^3 will be denoted by $[\ell]$.

One can get some insight into the structure of \mathbb{G} using row reduction. Let $V = \mathbb{C}^4$, let u_1, u_2 be a basis of a two-dimensional subspace U of V and let M be the 2×4 matrix whose rows are u_1, u_2 . The rows of the matrix M' obtained from M by row reduction span the same space U , and the row-reduced matrix M' is uniquely determined by U . Provided that the left hand 2×2 submatrix of M is invertible, M' will have the form

*rowre-
duced*

$$(3.7.1) \quad M' = \begin{pmatrix} 1 & 0 & * & * \\ 0 & 1 & * & * \end{pmatrix}$$

So the Grassmanian \mathbb{G} contains, as an open subset, a four-dimensional affine space whose coordinates are the variable entries of M' .

In any 2×4 matrix M with independent rows, some pair of columns will be independent, and the corresponding 2×2 submatrix will be invertible. That pair of columns can be used in place of the first two in a row reduction. So \mathbb{G} is covered by six four-dimensional affine spaces that we denote by \mathbb{W}^{ij} , $1 \leq i < j \leq 4$, \mathbb{W}^{ij} being the space of 2×4 matrices such that column i is $(1, 0)^t$ and column j is $(0, 1)^t$. Since \mathbb{P}^4 and the Grassmanian are both covered by affine spaces of dimension four, they may seem similar, but they aren't the same.

(3.7.2) the exterior algebra

extalgone

Let V be a complex vector space. The *exterior algebra* $\bigwedge V$ (read 'wedge V ') is a noncommutative ring that contains the complex numbers and is generated by the elements of V , with the relations

(3.7.3)
$$vw = -wv \quad \text{for all } v, w \text{ in } V.$$

extalg

3.7.4. Lemma. *The condition (3.7.3) is equivalent with: $vv = 0$ for all v in V .*

vvzero

proof. To get $vv = 0$ from (3.7.3), one sets $w = v$. Suppose that $vv = 0$ for all v in V . Then $(v+w)(v+w) = vv + ww = 0$. Since $(v+w)(v+w) = vv + vw + wv + ww$, it follows that $vw + wv = 0$. \square

To familiarize yourself with computation in $\bigwedge V$, verify that $v_3v_2v_1 = -v_1v_2v_3$ and that $v_4v_3v_2v_1 = v_1v_2v_3v_4$.

Let $\bigwedge^r V$ denote the subspace of $\bigwedge V$ spanned by products of length r of elements of V . The exterior algebra $\bigwedge V$ is the direct sum of those subspaces $\bigwedge^r V$. An algebra A that is a direct sum of subspaces A^i , and such that multiplication maps $A^i \times A^j$ to A^{i+j} is called a *graded algebra*. Since its multiplication law isn't commutative, the exterior algebra is a noncommutative graded algebra.

3.7.5. Proposition. *If (v_1, \dots, v_n) is a basis for V , the products $v_{i_1} \cdots v_{i_r}$ of length r with increasing indices $i_1 < i_2 < \cdots < i_r$ form a basis for $\bigwedge^r V$.*

dependentproduct

The proof is at the end of the section.

3.7.6. Corollary. *Let v_1, \dots, v_r be elements of V . The product $v_1 \cdots v_r$ is zero in $\bigwedge^r V$ if and only if the set (v_1, \dots, v_r) is dependent.* \square

wedgezero

For the rest of the section, we let V be a vector space of dimension four with basis (v_1, \dots, v_4) . Proposition 3.7.5 tells us that

(3.7.7)

- $\bigwedge^0 V = \mathbb{C}$ is a space of dimension 1, with basis $\{1\}$
- $\bigwedge^1 V = V$ is a space of dimension 4, with basis $\{v_1, v_2, v_3, v_4\}$
- $\bigwedge^2 V$ is a space of dimension 6, with basis $\{v_i v_j \mid i < j\} = \{v_1 v_2, v_1 v_3, v_1 v_4, v_2 v_3, v_2 v_4, v_3 v_4\}$
- $\bigwedge^3 V$ is a space of dimension 4, with basis $\{v_i v_j v_k \mid i < j < k\} = \{v_1 v_2 v_3, v_1 v_2 v_4, v_1 v_3 v_4, v_2 v_3 v_4\}$
- $\bigwedge^4 V$ is a space of dimension 1, with basis $\{v_1 v_2 v_3 v_4\}$
- $\bigwedge^q V = 0$ when $q > 4$.

extbasistwo

The elements of $\bigwedge^2 V$ are combinations

(3.7.8)
$$w = \sum_{i < j} a_{ij} v_i v_j$$

wedgetwo

We regard $\bigwedge^2 V$ as an affine space of dimension 6, identifying the combination w with the vector whose coordinates are the six coefficients a_{ij} ($i < j$). We use the same symbol w to denote the element (3.7.8) and the point $(a_{12}, a_{13}, a_{14}, a_{23}, a_{24}, a_{34})$ of the projective space \mathbb{P}^5 .

3.7.9. Definition. An element w of $\bigwedge^2 V$ is *decomposable* if it is a product of two elements of V .

defdecomp

de-
scribede-
comp
eqgrass

3.7.10. Proposition. *The decomposable elements of $\wedge^2 V$ are those such that $ww = 0$, and the relation $ww = 0$ is given by the following equation in the coefficients a_{ij} of $w = \sum_{i < j} a_{ij}v_iv_j$:*

$$(3.7.11) \quad a_{12}a_{34} - a_{13}a_{24} + a_{14}a_{23} = 0$$

proof. If w is decomposable, say $w = u_1u_2$, then $w^2 = u_1u_2u_1u_2 = -u_1^2u_2^2$ is zero because $u_1^2 = 0$. For the converse, we compute w^2 when $w = \sum_{i < j} a_{ij}v_iv_j$. The answer is

$$ww = 2(a_{12}a_{34} - a_{13}a_{24} + a_{14}a_{23})v_1v_2v_3v_4$$

To show that w is decomposable if $w^2 = 0$, it seems simplest to factor w explicitly. Since the assertion is trivial when $w = 0$, we may suppose that some coefficient of w is nonzero. If $w^2 = 0$ but $w_{12} \neq 0$, w will be the product

$$(3.7.12) \quad w = \frac{1}{a_{12}}(a_{12}v_2 + a_{13}v_3 + a_{14}v_4)(-a_{12}v_1 + a_{23}v_3 + a_{24}v_4)$$

The computation for any other pair of indices is similar. □

de-
comptwo

3.7.13. Corollary. (i) *Let w be a nonzero decomposable element of $\wedge^2 V$, say $w = u_1u_2$, with u_i in V . Then (u_1, u_2) is a basis for a two-dimensional subspace of V .*

(ii) *Let (u_1, u_2) and (u'_1, u'_2) be bases for the subspace U and U' of V . Then $U = U'$, if and only if $w = u_1u_2$ and $w' = u'_1u'_2$ differ by a scalar factor, i.e., if and only if they represent the same point of \mathbb{P}^5 .*

(iii) *Let u_1, u_2 be a basis for a two-dimensional subspace U of V , and let $w = u_1u_2$. The rule $\epsilon(U) = w$ defines a bijection ϵ from \mathbb{G} to the quadric Q in \mathbb{P}^5 whose equation is (3.7.11).*

Thus the Grassmanian \mathbb{G} can be represented as the quadric (3.7.11).

proof. (i) If an element w of $\wedge^2 V$ is decomposable, say $w = u_1u_2$, and if w is nonzero, then u_1 and u_2 must be independent (3.7.6). They span a two-dimensional subspace.

(ii) Suppose that $U' = U$. Then, when we write the second basis in terms of the first one, say $(u'_1, u'_2) = (au_1 + bu_2, cu_2 + du_2)$, the product w' becomes the scalar multiple $(ad - bc)w$ of w , and $ad - bc \neq 0$.

If $U' \neq U$, then at least three of the vectors u_1, u_2, u'_1, u'_2 will be independent. Say that u_1, u_2, u'_1 are independent. Then, according to Corollary 3.7.6, $u_1u_2u'_1 \neq 0$. Since $u'_1u'_2u'_1 = 0$, $u'_1u'_2$ cannot be a scalar multiple of u_1u_2 .

(iii) This follows from (i),(ii). □

For the rest of this section, we use the algebraic dimension of a variety, a concept that will be studied in the next chapter. We refer to the algebraic dimension simply as the *dimension*. The *dimension* of a variety X can be defined as the length d of the longest chain $C_0 > C_1 > \dots > C_d$ of closed subvarieties of X .

The topological dimension of X , its dimension in the classical topology, is always twice the algebraic dimension. Because the Grassmanian \mathbb{G} is covered by affine spaces of dimension 4, its algebraic dimension is 4 and its topological dimension is 8.

pinlclosed

3.7.14. Proposition. *Let \mathbb{P}^3 be the projective space associated to a four dimensional vector space V . In the product $\mathbb{P}^3 \times \mathbb{G}$, the locus Γ of pairs $p, [\ell]$ such that the point p of \mathbb{P}^3 lies on the line ℓ is a closed subset of dimension 5.*

proof. Let ℓ be the line in \mathbb{P}^3 that corresponds to the subspace U with basis (u_1, u_2) , and say that p is represented by a vector x in V . Let $w = u_1u_2$. Then $p \in \ell$ means $x \in U$, which is true if and only if (x, u_1, u_2) is a dependent set, and this happens if and only if $xw = 0$ (3.7.5). So Γ is the closed subset of points (x, w) of $\mathbb{P}^3 \times \mathbb{P}^5$ defined by the bihomogeneous equations $w^2 = 0$ and $xw = 0$. □

When we project Γ to \mathbb{G} , The fibre over a point $[\ell]$ of \mathbb{G} is the set of points $p, [\ell]$ such that p is a point of ℓ . The fibre maps bijectively to the line ℓ . Thus Γ can be viewed as a family of lines, parametrized by the four-dimensional variety \mathbb{G} of X . Its dimension is $\dim \ell + \dim \mathbb{G} = 1 + 4 = 5$.

linesina-
surface

(3.7.15) lines on a surface

One may ask whether or not a given surface in \mathbb{P}^3 contains a line. One surface that contains lines is the quadric Q in \mathbb{P}^3 with equation $w_{01}w_{10} = w_{00}w_{11}$, the image of the Segre embedding $\mathbb{P}^1 \times \mathbb{P}^1 \rightarrow \mathbb{P}_w^3$ (3.1.7). It contains two families of lines, corresponding to the two “rulings” $p \times \mathbb{P}^1$ and $\mathbb{P}^1 \times q$ of $\mathbb{P}^1 \times \mathbb{P}^1$. There are surfaces of arbitrary degree that contain lines, but a generic surface of degree four or more doesn’t contain any line.

We use coordinates x_i with $i = 1, 2, 3, 4$ for \mathbb{P}^3 here. There are $N = \binom{d+3}{3}$ monomials of degree d in four variables, so homogeneous polynomials of degree d are parametrized by an affine space of dimension N , and surfaces of degree d in \mathbb{P}^3 by a projective space of dimension $N - 1$. Let \mathbb{S} denote that projective space, and let $[S]$ denote the point of \mathbb{S} that corresponds to a surface S . The coordinates of $[S]$ are the coefficients of the monomials in the defining polynomial f of S . Speaking informally, we say that a point of \mathbb{S} “is” a surface of degree d in \mathbb{P}^3 . (When f is reducible, its zero locus isn’t a variety. Let’s not worry about this.)

Consider the line ℓ_0 defined by $x_3 = x_4 = 0$. Its points are those of the form $(x_1, x_2, 0, 0)$, so a surface $S : \{f = 0\}$ will contain ℓ_0 if and only if $f(x_1, x_2, 0, 0) = 0$ for all x_1, x_2 . Substituting $x_3 = x_4 = 0$ into f leaves us with a polynomial in two variables:

$$(3.7.16) \quad f(x_1, x_2, 0, 0) = c_0 x_1^d + c_1 x_1^{d-1} x_2 + \cdots + c_d x_2^d$$

scon-
tainslzero

where c_i are some of the coefficients of the polynomial f . If $f(x_1, x_2, 0, 0)$ is identically zero, all of those coefficients must be zero. So the surfaces that contain ℓ_0 correspond to the points of the linear subspace \mathbb{L}_0 of \mathbb{S} defined by the equations $c_0 = \cdots = c_d = 0$. Its dimension is $(N - 1) - (d + 1) = N - d - 2$. This is a satisfactory answer to the question of which surfaces contain ℓ_0 , and we can use it to make a guess about lines in a generic surface of degree d .

3.7.17. Lemma. *In the product variety $\mathbb{G} \times \mathbb{S}$, the set Γ_d of pairs $[\ell], [S]$ such that ℓ is a line, S is a surface of degree d , and $\ell \subset S$ is closed.*

scon-
tainslclosed

proof. Let \mathbb{W}^{ij} , $1 \leq i < j \leq 4$ denote the six affine spaces that cover the Grassmanian, as at the beginning of this section. It suffices to show that the intersection $\Gamma_d^{ij} = \Gamma_d \cap (\mathbb{W}^{ij} \times \mathbb{S})$ is closed in $\mathbb{W}^{ij} \times \mathbb{S}$ for all i, j (3.5.13). We inspect the case $i, j = 1, 2$.

A line ℓ such that $[\ell]$ is in \mathbb{W}^{12} corresponds to a subspace of \mathbb{C}^2 with basis of the form $u_1 = (1, 0, a_2, a_3)$, $u_2 = (0, 1, b_2, b_3)$ and ℓ is the line whose points are combinations $ru_1 + su_2$ of u_1, u_2 . Let $f(x_1, x_2, x_3, x_4)$ be the polynomial that defines a surface S of degree d . The line ℓ is contained in S if and only if $f(r, s, ra_2 + sb_2, ra_3 + sb_3)$ is zero for all r and s . This is a homogeneous polynomial of degree d in r, s . Let’s call it $\tilde{f}(r, s)$. If we write $\tilde{f}(r, s) = z_0 r^d + z_1 r^{d-1} s + \cdots + z_d s^d$, the coefficients z_ν will be polynomials in a_i, b_i and in the coefficients of f . The locus $z_0 = \cdots = z_d = 0$ is the closed set Γ_d^{12} of $\mathbb{W}^{12} \times \mathbb{S}$. \square

The set of surfaces that contain our special line ℓ_0 corresponds to the linear space \mathbb{L}_0 of \mathbb{S} of dimension $N - d - 2$, and ℓ_0 can be carried to any other line ℓ by a linear map $\mathbb{P}^3 \rightarrow \mathbb{P}^3$. So the surfaces that contain another line ℓ also form a linear subspace of \mathbb{S} of dimension $N - d - 2$. Those subspaces are the fibres of Γ_d over \mathbb{G} . The dimension of the Grassmanian \mathbb{G} is 4. Therefore the dimension of Γ_d is $\dim \Gamma_d = \dim \mathbb{L}_0 + \dim \mathbb{G} = (N - d - 2) + 4$. Since \mathbb{S} has dimension $N - 1$,

$$(3.7.18) \quad \dim \Gamma_d = \dim \mathbb{S} - d + 3$$

dimspace-
lines

We project the product $\mathbb{G} \times \mathbb{S}$ and its subvariety Γ_d to \mathbb{S} . The fibre of Γ_d over a point $[S]$ is the set of pairs $[\ell], [S]$ such that ℓ is contained in S – the set of lines in S .

When the degree d of the surfaces we are studying is 1, $\dim \Gamma_d = \dim \mathbb{S} + 2$. Every fibre of Γ_d over \mathbb{S} will have dimension at least 2. In fact, every fibre has dimension equal to 2. Surfaces of degree 1 are planes, and the lines in a plane form a two-dimensional family.

When $d = 2$, $\dim \Gamma_2 = \dim \mathbb{S} + 1$. We can expect that most fibres of Γ_2 over \mathbb{S} will have dimension 1. This is true: A smooth quadric contains two one-dimensional families of lines. (All smooth quadrics are equivalent with the quadric (3.1.8).) But if a quadratic polynomial $f(x_1, x_2, x_3, x_4)$ is the product of linear polynomials, its locus of zeros will be a union of planes. It will contain two-dimensional families of lines. Some fibres have dimension 2.

When $d \geq 4$, $\dim \Gamma_d < \dim \mathbb{S}$. The projection $\Gamma_d \rightarrow \mathbb{S}$ cannot be surjective. Most surfaces of degree 4 or more contain no lines.

The most interesting case is that $d = 3$. In this case, $\dim \Gamma_3 = \dim \mathbb{S}$. Most fibres will have dimension zero. They will be finite sets. In fact, a generic cubic surface contains 27 lines. We have to wait to see why the number is precisely 27 (see Theorem 4.7.18).

Our conclusions are intuitively plausible, but to be sure about them, we need to study dimension carefully. We do this in the next chapters.

proof of Proposition 3.7.5. Let $v = (v_1, \dots, v_n)$ be a basis of the vector space V . The proposition asserts that the products $v_{i_1} \cdots v_{i_r}$ of length r with increasing indices $i_1 < i_2 < \cdots < i_r$ form a basis for $\bigwedge^r V$.

To prove this, we need to be more precise about the definition of the exterior algebra $\bigwedge V$. We start with the algebra $T(V)$ of noncommutative polynomials in the basis v , which is also called the *tensor algebra* on V . The part $T^r(V)$ of $T(V)$ of degree r has as basis the n^r noncommutative monomials of degree r , products $v_{i_1} \cdots v_{i_r}$ of length r of elements of the basis v . Its dimension is n^r . When $n = r = 2$, $T^2(V)$ has the basis $(x_1^2, x_1x_2, x_2x_1, x_2^2)$.

The exterior algebra $\bigwedge V$ is the quotient of $T(V)$ obtained by forcing the relations $vw + wv = 0$ (3.7.3). Using the distributive law, one sees that the relations $v_i v_j + v_j v_i = 0$, $1 \leq i, j \leq n$, are sufficient to define this quotient. The relations $v_i v_i = 0$ are included when $i = j$.

To obtain $\bigwedge^r V$, we multiply the relations $v_i v_j + v_j v_i$ on left and right by arbitrary noncommutative monomials $p(v)$ and $q(v)$ in v_1, \dots, v_n whose degrees sum to $r-2$. The noncommutative polynomials

$$(3.7.19) \quad p(v_i v_j + v_j v_i) q$$

span the kernel of the linear map $T^r(V) \rightarrow \bigwedge^r V$. So in $\bigwedge^r V$, $p(v_i v_j) q = -p(v_j v_i) q$. Using these relations, any product $v_{i_1} \cdots v_{i_r}$ in $\bigwedge^r V$ is, up to sign, equal to a product in which the indices i_ν are in increasing order. Thus the products with indices in increasing order span $\bigwedge^r V$, and because $v_i v_i = 0$, such a product will be zero unless the indices are strictly increasing.

We go to the proof now. Let $v = (v_1, \dots, v_n)$ be a basis for V . We show first that the product $w = v_1 \cdots v_n$ of the basis elements of V in increasing order is a basis of the one-dimensional space $\bigwedge^n V$. We have shown that this product spans $\bigwedge^n V$, and it remains to show that $w \neq 0$, or that $\bigwedge^n V \neq 0$.

Let's use multi-index notation: $(i) = (i_1, \dots, i_r)$, and $v_{(i)} = v_{i_1} \cdots v_{i_r}$. We define a surjective linear map $T^n(V) \xrightarrow{\varphi} \mathbb{C}$. The products $v_{(i)} = (v_{i_1} \cdots v_{i_n})$ of length n form a basis of $T^n(V)$. If there is no repetition among the indices i_1, \dots, i_n , then (i) will be a permutation of the indices $1, \dots, n$. In that case, we set $\varphi(v_{(i)}) = \varphi(v_{i_1} \cdots v_{i_n}) = \text{sign}(i)$. If there is a repetition, we set $\varphi(v_{(i)}) = 0$.

Let p and q be noncommutative monomials whose degrees sum to $n-2$. If the product $p(v_i v_j) q$ has no repeated index, the indices in $p(v_i v_j) q$ and $p(v_j v_i) q$ will be permutations of $1, \dots, n$, and those permutations will have opposite signs. Then $p(v_i v_j + v_j v_i) q$ will be in the kernel of φ . Since these elements span the space of relations that define $\bigwedge^n V$ as a quotient of $T^n(V)$, the surjective map $T^n(V) \xrightarrow{\varphi} \mathbb{C}$ defines a surjective map $\bigwedge^n V \rightarrow \mathbb{C}$. Therefore $\bigwedge^n V \neq 0$.

To prove (3.7.5), we must show that for $r \leq n$, the products $v_{i_1} \cdots v_{i_r}$ with $i_1 < i_2 < \cdots < i_r$ form a basis for $\bigwedge^r V$, and we know that those products span $\bigwedge^r V$. We must show that they are independent. Suppose that a combination $z = \sum c_{(i)} v_{(i)}$ is zero, the sum being over sets of strictly increasing indices. We choose a set (j_1, \dots, j_r) of n strictly increasing indices, and we let $(k) = (k_1, \dots, k_{n-r})$ be the set of $n-r$ indices that don't occur in (j) , listed in arbitrary order. Then all terms in the sum $z v_{(k)} = \sum c_{(i)} v_{(i)} v_{(k)}$ will be zero except the term with $(i) = (j)$. On the other hand, since $z = 0$, $z v_{(k)} = 0$. Therefore $c_{(j)} v_{(j)} v_{(k)} = 0$, and since $v_{(j)} v_{(k)}$ differs by sign from $v_1 \cdots v_n$, it isn't zero. It follows that $c_{(j)} = 0$. This is true for all (j) , so $z = 0$. \square

3.8 Exercises

- 3.8.1.** Let X be the affine surface in \mathbb{A}^3 defined by the equation $x_1^3 + x_1x_2x_3 + x_1x_3 + x_2^2 + x_3 = 0$, and let \overline{X} be its closure in \mathbb{P}^3 . Describe the intersection of \overline{X} with the plane at infinity in \mathbb{P}^3 . ch08reinP
threeex
- 3.8.2.** Let V be a vector space of dimension 5, let \mathbb{G} denote the Grassmanian $G(2, 5)$ of lines in \mathbb{P}^4 , let $W = \bigwedge^2 V$, and let D denote the subset of decomposable vectors in the projective space $\mathbb{P}(W)$ of one-dimensional subspaces of W . Prove that there is a bijective correspondence between two-dimensional subspaces U of V and the points of D , and that a vector w in $\bigwedge^2 V$ is decomposable if and only if $w^2 = 0$. Exhibit defining equations for \mathbb{G} in the space $\mathbb{P}(W)$. xlinesp-
five
- 3.8.3.** Let f and g be irreducible homogeneous polynomials in x, y, z . Prove that if the loci $\{f = 0\}$ and $\{g = 0\}$ in \mathbb{P}^2 are equal, then $g = cf$. exsamelo-
cus
- 3.8.4.** Prove that relatively prime polynomials in F, G two variables x, y , not necessarily homogeneous, have finitely many common zeros in \mathbb{A}^2 . xxfin-
manyzeros
- 3.8.5.** Let C be a cubic curve, the locus of a homogeneous cubic polynomial $f(x, y, z)$ in \mathbb{P}^2 . Suppose that (001) and (010) are flex points of C , that the tangent line to C at (001) is the line $\{y = 0\}$, and the tangent line at (010) is the line $\{z = 0\}$. What are the possible polynomials f ? Disregard the question of whether f is irreducible. xcubiceq
- 3.8.6.** Let f a homogeneous polynomial in x, y, z , not divisible by z . Prove that f is irreducible if and only if $f(x, y, 1)$ is irreducible. xf-
zoneirred
- 3.8.7.** Let f be an irreducible polynomial in $\mathbb{C}[x_1, \dots, x_n]$, and let A finite-type domain. Prove that f an irreducible element of $A[x]$. xfirredAx
- 3.8.8.** Let f and g be irreducible homogeneous polynomials in x, y, z . Prove that if the loci $\{f = 0\}$ and $\{g = 0\}$ are equal, then g is a constant multiple of f . xsamelo-
cus
- 3.8.9.** Let \mathcal{P} be a homogeneous ideal in $\mathbb{C}[x_0, \dots, x_n]$ whose dehomogenization P is a prime ideal. Is \mathcal{P} a prime ideal? homog-
primecon-
verse
xideali-
nAxP
xlocusin-
PxP
- 3.8.10.** Describe the ideals that define closed subsets of $\mathbb{A}^m \times \mathbb{P}^n$.
- 3.8.11.** With coordinates x_0, x_1, x_2 in the plane \mathbb{P} and s_0, s_1, s_2 in the dual plane \mathbb{P}^* , let C be a smooth projective plane curve $f = 0$ in \mathbb{P} , where f is an irreducible homogeneous polynomial in x . Let Γ be the locus of pairs (x, s) of $\mathbb{P} \times \mathbb{P}^*$ such that the line $s_0x_0 + s_1x_1 + s_2x_2 = 0$ is the tangent line to C at x . Prove that Γ is a Zariski closed subset of the product $\mathbb{P} \times \mathbb{P}^*$.
- 3.8.12.** Let Y and Z be the zero sets in \mathbb{P} of relatively prime homogeneous polynomials g and h of the same degree r . Prove that the rational function $\alpha = g/h$ will tend to infinity as one approaches a point of Z that isn't also a point of Y and that, at intersections of Y and Z , α is indeterminate in the sense that the limit depends on the path. xtendtoinf
- 3.8.13.** Let $f = x_0^2 - x_1x_2$. Determine generators and defining relations for the ring $\mathcal{R}_{\{f\}}$ of homogeneous fractions of degree zero whose denominator is a power of f . exgenrel
- 3.8.14.** Let U be a nonempty open subset of \mathbb{P}^n . Prove that if a rational function is bounded on U , it is a constant. xfn-
bounded
- 3.8.15.** Let Y be the cusp curve $\text{Spec } B$, where $B = \mathbb{C}[x, y]/(y^2 - x^3)$. This algebra embeds as subring into $\mathbb{C}[t]$, by $x = t^2$, $y = t^3$. Show that the two vectors $v_0 = (x-1, y-1)$ and $v_1 = (t+1, t^2+t+1)$ define the same point of \mathbb{P}^1 with values in the fraction field K of B , and that they define morphisms from Y to \mathbb{P}^1 wherever the entries are regular functions on Y . Prove that the two morphisms they define piece together to give a morphism $Y \rightarrow \mathbb{P}^1$. xmapcusp
- 3.8.16.** Let C be a conic in \mathbb{P}^2 , and let π be the projection to \mathbb{P}^1 from a point q of C . Prove that there is no way to extend this map to a morphism from \mathbb{P}^2 to \mathbb{P}^2 .

3.8.17. Verify that the following maps are morphisms of projective varieties:

- (a) the projection from a product variety $X \times Y$ to X ,
- (b) the inclusion of X into the product $X \times Y$ as the set $X \times y$ for a point y of Y ,
- (c) the morphism of products $X \times Y \rightarrow X' \times Y$ when a morphism $X \rightarrow X'$ is given.

3.8.18. Let X be the open complement of a closed subset Y in a projective variety \overline{X} in \mathbb{P}^n . Say that \overline{X} is the set of solutions of the homogeneous polynomial equations $f = 0$ and that Y is the set of solutions of the equations $g = 0$. What conditions must a point p of \mathbb{P}^n satisfy in order to be a point of X ?

zautPone

3.8.19. A pair f_0, f_1 of homogeneous polynomials in x_0, x_1 of the same degree d can be used to define a morphism $\mathbb{P}^1 \rightarrow \mathbb{P}^1$. At a point q , the morphism evaluates $(1, f_1/f_0)$ or $(f_0/f_1, 1)$ at q .

- (a) The *degree* of such a morphism is the number of points in a generic fibre. Determine the degree.
- (b) Describe the group of automorphisms of \mathbb{P}^1 .

xmorph-Ptwo

3.8.20. (a) What are the conditions that a triple of $f = (f_0, f_1, f_2)$ homogeneous polynomials in x_0, x_1, x_2 of the same degree d must satisfy in order to define a morphism $\mathbb{P}^2 \rightarrow \mathbb{P}^2$?

- (b) If f does define a morphism, what is its degree?

cuspto-pone

3.8.21. Let C be the projective plane curve $x^3 - y^2z = 0$.

- (a) Show that the function field K of C is the field $\mathbb{C}(t)$ of rational functions in $t = y/x$.
- (b) Show that the point $(t^2 - 1, t^3 - 1)$ of \mathbb{P}^1 with values in K defines a morphism $C \rightarrow \mathbb{P}^1$.

easyk-leiman

3.8.22. Prove that every finite subset S of a projective variety X is contained in an affine open subset.

3.8.23. Describe the affine open subsets of the projective plane \mathbb{P}^2 .

xflag

3.8.24. Let $\mathbb{P} = \mathbb{P}^3$. The space of planes in \mathbb{P} is the *dual projective space* \mathbb{P}^* . The variety F that parametrizes triples (p, ℓ, H) consisting of a point p , a line ℓ , and a plane H in \mathbb{P} , with $p \in \ell \subset H$, is called a *flag variety*. Exhibit defining equations for F in $\mathbb{P}^3 \times \mathbb{P}^5 \times \mathbb{P}^{3*}$. The equations should be homogeneous in each of 3 sets of variables.

xPtwo-Pone
xblowup

3.8.25. Describe all morphisms $\mathbb{P}^2 \rightarrow \mathbb{P}^1$.

3.8.26. (*blowing up a point in \mathbb{P}^2*) Consider the Veronese embedding of $\mathbb{P}^2_{xyz} \rightarrow \mathbb{P}^5_u$ by monomials of degree 2 defined by $(u_0, u_1, u_2, u_3, u_4, u_5) = (z^2, y^2, x^2, yz, xz, xy)$. If we drop the coordinate u_0 , we obtain a map $\mathbb{P}^2 \xrightarrow{\varphi} \mathbb{P}^4$: $\varphi(x, y, z) = (y^2, x^2, yz, xz, xy)$ that is defined at all points except the point $q = (0, 0, 1)$. Find defining equations for the closure of the image X . Prove that the inverse map $X \xrightarrow{\varphi^{-1}} \mathbb{P}^2$ is everywhere defined, and that the fibre of φ^{-1} over q is a projective line.

xconic-cubic

3.8.27. Show that the conic C in \mathbb{P}^2 defined by the polynomial $y_0^2 + y_1^2 + y_2^2 = 0$ and the twisted cubic V in \mathbb{P}^3 , the zero locus of the polynomials $v_0v_2 - v_1^2, v_0v_3 - v_1v_2, v_1v_3 - v_2^2$ are isomorphic by exhibiting inverse morphisms between them.

xmapplan-etoPone

3.8.28. Let X be the affine plane with coordinates (x, y) . Given a pair of polynomials $u(x, y), v(x, y)$ in x, y , one may try to define a morphism $f : X \rightarrow \mathbb{P}^1$ by $f(x, y) = (u, v)$. Under what circumstances is f a morphism?

xmap-toPthree

3.8.29. Let x_0, x_1, x_2 be the coordinate variables in the projective plane X . The function field K of X is the field of rational functions in the variables $u_1, u_2, u_i = x_i/x_0$. Let $f(u_1, u_2)$ and $g(u_1, u_2)$ be polynomials. Under what circumstances does the point $(1, f, g)$ with values in K define a morphism $X \rightarrow \mathbb{P}^2$?

Chapter 4 INTEGRAL MORPHISMS OF AFFINE VARIETIES

- 4.1 The Nakayama Lemma
- 4.2 Integral Extensions
- 4.3 Normalization
- 4.4 Geometry of Integral Morphisms
- 4.5 Dimension
- 4.6 Chevalley's Finiteness Theorem
- 4.7 Double Planes

The concept of an algebraic integer was one of the important ideas contributing to the development of algebraic number theory in the 19th century. Then, largely through the work of Noether and Zariski, an analog was seen to be essential in algebraic geometry. We study that analog in this chapter.

Section 4.1 The Nakayama Lemma

nakayama
eigen

(4.1.1) eigenvectors

It won't surprise you that eigenvectors are important, but the way that they are used to study modules may be unfamiliar.

Let P be an $n \times n$ matrix with entries in a ring A . The concept of an eigenvector for P makes sense when the entries of a vector are in an A -module. A column vector $v = (v_1, \dots, v_n)^t$ with entries in an A -module M is an *eigenvector* of P with *eigenvalue* λ in A if $Pv = \lambda v$.

When the entries of a vector are in a module, it becomes hard to adapt the usual requirement that an eigenvector must be nonzero, so we drop it, though the zero eigenvector tells us nothing.

eigenval

4.1.2. Lemma. *Let $p(t)$ be the characteristic polynomial $\det(tI - P)$ of a square matrix P . If v is an eigenvector of P with eigenvalue λ , then $p(\lambda)v = 0$.*

The usual proof, in which one multiplies the equation $(\lambda I - P)v = 0$ by the cofactor matrix of $(\lambda I - P)$, carries over. \square

The next lemma is a cornerstone of the theory of modules. In it, JM denotes the set of (finite) sums $\sum_i a_i m_i$ with a_i in J and m_i in M .

nakaya-
malem

4.1.3. Nakayama Lemma. Let M be a finite module over a ring A , and let J be an ideal of A such that $M = JM$. There is an element z in J such that $m = zm$ for all m in M , or such that $(1 - z)M = 0$.

Because it is always true that $M \supset JM$, the hypothesis $M = JM$ can be replaced by $M \subset JM$.

proof of the Nakayama Lemma.

Let v_1, \dots, v_n be generators for the finite A -module M , and let v be the vector $(v_1, \dots, v_n)^t$. The equation $M = JM$ tells us that there are elements p_{ij} in J such that $v_i = \sum p_{ij} v_j$, which we can rewrite in matrix notation, as $v = Pv$. So v is an eigenvector of P with eigenvalue 1, and if $p(t)$ is the characteristic polynomial of P , then $p(1)v = 0$. Since the entries of P are in J , inspection of the determinant of $I - P$ shows that $p(1)$ has the form $1 - z$, with z in the ideal J . Then $(1 - z)v_i = 0$ for all i . Since v_1, \dots, v_n generate M , $(1 - z)M = 0$. \square

4.1.4. Corollary. With notation as in the Nakayama Lemma, let $s = 1 - z$, so that $sM = 0$. The localized module M_s is the zero module. loczero

See (2.6.5). □

4.1.5. Corollary. (i) Let I and J be ideals of a noetherian domain A . If $I = JI$, then either I is the zero ideal or J is the unit ideal. idealzero

(ii) Let $A \subset B$ be rings, and suppose that B is a finite A -module. If J is an ideal of A , and if the extended ideal JB (2.6.3) is the unit ideal of B , then J is the unit ideal of A .

proof. **(i)** Since A is noetherian, I is a finite A -module. If $I = JI$, the Nakayama Lemma tells us that there is an element z of J such that $zx = x$ for all x in I . Suppose that I isn't the zero ideal. We choose a nonzero element x of I . Because A is a domain, we can cancel x from the equation $zx = x$, obtaining $z = 1$. Then 1 is in J , and J is the unit ideal.

(ii) The elements of the extended ideal JB are sums $\sum u_i b_i$ with u_i in J and b_i in B (2.6.3). Suppose that $B = JB$. The Nakayama Lemma tells us that there is an element z in J such that $zb = b$ for all b in B . Setting $b = 1$ shows that $z = 1$. So J is the unit ideal. □

4.1.6. Corollary. Let x be an element of a noetherian domain A , not a unit, and let J be the principal ideal xA . xkdividesy

(i) The intersection $\bigcap J^n$ is the zero ideal.

(ii) If y is a nonzero element of A , the integers k such that x^k divides y in A are bounded.

(iii) For every $k > 0$, $J^k \supsetneq J^{k+1}$.

proof. Let $I = \bigcap J^n$. The elements of I are the ones that are divisible by x^n for every n . Let y be such an element. So for every n , there is an element a_n in A such that $y = a_n x^n$. Then $y/x = a_n x^{n-1}$, which is an element of J^{n-1} . Since this is true for every n , y/x is in I , and y is in JI . Since y can be any nonzero element of I , $I = JI$. But since x isn't a unit, J isn't the unit ideal. So Corollary 4.1.5(i) tells us that $I = 0$. This proves **(i)**, and **(ii)** follows. For **(iii)**, we note that if $J^k = J^{k+1}$, then, multiplying by J^{n-k} shows that $J^n = J^{n+1}$ for every $n \geq k$, and therefore that $J^k = \bigcap J^n$. But the left is the zero ideal, and since A is a domain and $x \neq 0$, $J^k = x^k A \neq 0$. □

4.1.7. Corollary. Let I be a nonzero ideal of a noetherian domain A , let B be a domain that contains A as a subring, and let β be an element β of B . If $\beta I \subset I$, then β is integral over A . betainte-gral

proof. Because A is noetherian, I is finitely generated. Let $v = (v_1, \dots, v_n)^t$ be a vector whose entries generate I . The hypothesis $\beta I \subset I$ allows us to write $\beta v_i = \sum p_{ij} v_j$ with p_{ij} in A , or in matrix notation, $\beta v = P v$. So v is an eigenvector of P with eigenvalue β , and if $p(t)$ is the characteristic polynomial of P , then $p(\beta)v = 0$. Since at least one v_i is nonzero and since A is a domain, $p(\beta) = 0$. The characteristic polynomial $p(t)$ is a monic polynomial with coefficients in A , so β is integral over A . □

Section 4.2 Integral Extensions

Let A be a domain. An *extension* of A is a domain that contains A as a subring. int

Let B be an extension of A . An element β of B is *integral over A* if it is a root of a monic polynomial

$$(4.2.1) \quad f(x) = x^n + a_{n-1}x^{n-1} + \dots + a_0$$
eqn

with coefficients a_i in A , and B is an *integral extension* of A if all elements of B are integral over A .

4.2.2. Lemma. Let $A \subset B$ be an extension of domains. aboutinte-gral

(i) An element b of B is integral over A if and only if the subring $A[b]$ of B generated by b is a finite A -module.

(ii) The set of elements of B that are integral over A is a subring of B .

(iii) If B is generated as A -algebra by finitely many integral elements, it is a finite A -module.

(iv) Let $R \subset A \subset B$ be rings, and suppose that A is an integral extension of R . An element of B is integral over A if and only if it is integral over R . □

inte-
gralfinite

4.2.3. Corollary. An extension $A \subset B$ of finite-type domains is an integral extension if and only if B is a finite A -module. \square

deffinmor-
phaff

4.2.4. Definition. Let $Y \xrightarrow{u} X$ be a morphism of affine varieties $Y = \text{Spec } B$ and $X = \text{Spec } A$, and let $A \xrightarrow{\varphi} B$ be the corresponding homomorphism of coordinate algebras. If φ makes B into a finite A -module, we call u a *finite morphism* (of affine varieties). If A is a subring of B , and B is an integral extension of A , we call u an *integral morphism*.

An integral morphism of affine varieties is a finite morphism whose associated algebra homomorphism $A \xrightarrow{\varphi} B$ is injective.

invarinte-
gral

4.2.5. Example. Let G be a finite group of automorphisms of a finite-type domain B and let $A = B^G$ be the algebra of invariants. Then B is an integral extension of A . (Theorem 2.8.5.) \square

The next example is helpful for an intuitive understanding of the geometric meaning of integrality.

inte-
gralovercx

4.2.6. Example. Let f be an irreducible polynomial in $\mathbb{C}[x, y]$ (one x and one y), let $B = \mathbb{C}[x, y]/(f)$, and let $A = \mathbb{C}[x]$. So $X = \text{Spec } A$ is the affine line \mathbb{A}_x^1 , and $Y = \text{Spec } B$ is a plane affine curve. The canonical map $A \rightarrow B$ defines a morphism $Y \xrightarrow{u} X$, which can be described as the restriction of the projection $\mathbb{A}_{x,y}^2 \rightarrow \mathbb{A}_x^1$ to Y .

We write f as a polynomial in y , whose coefficients $a_i(x)$ are polynomials in x :

fx y

$$(4.2.7) \quad f(x, y) = a_0(x)y^n + a_1(x)y^{n-1} + \cdots + a_n(x)$$

Let x_0 be a point of X . The fibre of Y over x_0 consists of the points (x_0, y_0) such that y_0 is a root of the one-variable polynomial $f(x_0, y) = \tilde{f}(y)$. Because f is irreducible, its discriminant $\delta(x)$ with respect to the variable y isn't identically zero. Then, for all but finitely many values of x , a_0 and δ will be nonzero, and $\tilde{f}(y)$ will have n distinct roots.

When $f(x, y)$ is a monic polynomial in y , u will be an integral morphism. If so, the leading term y^n of f will be the dominant term, when y is large. Near to any point x_0 of X , there will be a positive real number N such that

$$|y^n| > |a_1(x)y^{n-1} + \cdots + a_n(x)|$$

when $|y| > N$, and therefore $f(x, y) \neq 0$. So the roots y of $f(x, y)$ are bounded by N for all x near to x_0 .

On the other hand, when the leading coefficient $a_0(x)$ isn't a constant, B won't be integral over A . If x_0 is a root of $a_0(x)$, $f(x_0, y)$ will have degree less than n . What happens is that, as a point x_1 of X approaches x_0 , at least one root of $f(x_1, y)$ tends to infinity. In calculus, one says that the locus $f(x, y) = 0$ has a vertical asymptote at x_0 .

To see this, we divide f by its leading coefficient. Let $g(x, y) = f(x, y)/a_0 = y^n + c_1y^{n-1} + \cdots + c_n$ with $c_i(x) = a_i(x)/a_0(x)$. For any x at which $a_0(x)$ isn't zero, the roots of g are the same as those of f . However, let x_0 be a root of a_0 . Because f is irreducible. At least one coefficient $a_j(x)$ doesn't have x_0 as a root. Then $c_j(x)$ is unbounded near x_0 , and because the coefficient c_j is an elementary symmetric function in the roots, the roots can't all be bounded.

This is the general picture: The roots of a polynomial remain bounded where the leading coefficient isn't zero. If the leading coefficient vanishes at a point, some roots are unbounded near that point. \square

figure : nonmonic polynomial, but compare with figure for Hensel's Lemma

noether-
normal

4.2.8. Noether Normalization Theorem. Let A be a finite-type algebra over an infinite field k . There exist elements y_1, \dots, y_n in A that are algebraically independent over k , such that A is an integral extension of its polynomial subalgebra $P = k[y_1, \dots, y_n]$, i.e., such that A is a finite module over P .

When $k = \mathbb{C}$, the theorem can be stated by saying that every affine variety X admits an integral morphism to an affine space.

The Noether Normalization Theorem is also true when k is a finite field, but the proof given below needs to be modified.

4.2.9. Lemma. *Let k be an infinite field, and let $f(x)$ be a nonzero polynomial of degree d in x_1, \dots, x_n , with coefficients in k . After a suitable linear change of variable, the coefficient of x_n^d in f will be nonzero.*

nonzero-coeff

proof. Let f_d be the homogeneous part of f of maximal degree d . We regard f_d as a polynomial function. Since k is infinite, this function isn't identically zero. We choose coordinates x_1, \dots, x_n so that the point $q = (0, \dots, 0, 1)$ isn't a zero of f_d . Then $f_d(0, \dots, 0, x_n) = cx_n^d$, and the coefficient c , which is $f_d(0, \dots, 0, 1)$, will be nonzero. By scaling, we can make $c = 1$. \square

proof of the Noether Normalization Theorem. Say that the finite-type algebra A is generated by elements x_1, \dots, x_n . If those elements are algebraically independent over k , A will be isomorphic to the polynomial algebra $\mathbb{C}[x]$, and we will be done. If not, they will satisfy a polynomial relation $f(x) = 0$ of some degree d , with coefficients in k . The lemma tells us that, after a suitable change of variable, the coefficient of x_n^d in f will be 1. Then f will be a monic polynomial in x_n with coefficients in the subalgebra R generated by x_1, \dots, x_{n-1} . So x_n will be integral over R , and A will be a finite R -module. By induction on n , we may assume that R is a finite module over a polynomial subalgebra P . Then A will be a finite module over P too. \square

The next corollary is an example of a general principle, that a construction involving finitely many operations can be done in a simple localization. (See (2.6.10).)

4.2.10. Corollary. *Let $A \subset B$ be finite-type domains. There is a nonzero element s in A such that B_s is a finite module over a polynomial subring $A_s[y_1, \dots, y_r]$.*

localinthem

proof. Let S be the set of nonzero elements of A , so that $K = AS^{-1}$ is the fraction field of A , and let $B_K = BS^{-1}$ be the ring obtained from B by inverting all elements of S . Also, let $\beta = (\beta_1, \dots, \beta_k)$ be a set of algebra generators for the finite-type algebra B . Then B_K is generated as K -algebra by β . It is a finite-type K -algebra. The Noether Normalization Theorem tells us that B_K is a finite module over a polynomial subring $P = K[y_1, \dots, y_r]$. So B_K is an integral extension of P . Any element of B will be in B_K , and therefore it will be the root of a monic polynomial, say

$$f(x) = x^n + c_{n-1}x^{n-1} + \dots + c_0 = 0$$

where the coefficients $c_j(y)$ are elements of P . Each coefficient c_j is a combination of finitely many monomials in y , with coefficients in K . If $d \in A$ is a common denominator for those coefficients, $c_j(x)$ will have coefficients in $A_d[y]$. Since the generators β of B are integral over P , we may choose a denominator s so that the generators β_1, \dots, β_k are all integral over $A_s[y]$. The algebra B_s is generated over A_s by β , so B_s will be an integral extension of $A_s[y]$. \square

Section 4.3 Normalization

Let A be a domain with fraction field K . The *normalization* $A^\#$ of A is the set of elements of K that are integral over A . It follows from Lemma 4.2.2 (ii) that the normalization is a domain that contains A .

finint

A domain A is *normal* if it is equal to its normalization, and a *normal variety* X is a variety that has an affine covering $\{X^i = \text{Spec } A_i\}$ in which the algebras A_i are normal domains.

To justify the definition of normal variety, we need to show that if an affine variety $X = \text{Spec } A$ has an affine covering $X^i = \text{Spec } A_i$, in which A_i are normal domains, then A is normal. This follows from Lemma 4.3.4 (iii) below.

Our goal here is the next theorem, whose proof is at the end of the section.

4.3.1. Theorem. *Let A be a finite-type domain with fraction field K of characteristic zero. The normalization $A^\#$ of A is a finite A -module and a finite-type domain.*

normalfinite

Thus there will be an integral morphism $\text{Spec } A^\# \rightarrow \text{Spec } A$.

4.3.2. Corollary. *With notation as above, there is a non zero element $s \in A$ such that $sA^\# \subset A$.*

Asharp-modA

proof. Since A and $A^\#$ have the same fraction field, every element α of $A^\#$ can be written as a fraction $\alpha = a/s$ with a, s in A . Then $s\alpha \in A$. Since $A^\#$ is a finite A -module, one can find a nonzero element $s \in A$ such that $a\alpha$ is in A for all α in $A^\#$. \square

The proof given here makes use of the characteristic zero hypothesis, though the theorem is true for a finite-type algebra over any field k .

4.3.3. Example. (*normalization of a nodal cubic curve*) The algebra $A = \mathbb{C}[u, v]/(v^2 - u^3 - u^2)$ can be embedded into the one-variable polynomial algebra $B = \mathbb{C}[x]$, by $u = x^2 - 1$ and $v = x^3 - x$. The fraction fields of A and B are equal because $x = v/u$, and the equation $x^2 - (u+1) = 0$ shows that x is integral over A . The algebra B is normal, so it is the normalization of A (see Lemma 4.3.4 (i)).

In this example, the plane curve $C = \text{Spec } A$ has a node at the origin $p = (0, 0)$, and $\text{Spec } B$ is the affine line \mathbb{A}_x^1 . The inclusion $A \subset B$ defines an integral morphism $\mathbb{A}_x^1 \rightarrow C$ whose fibre over p is the point pair $x = \pm 1$. The morphism is bijective at all other points. I think of C as the variety obtained by gluing the points $x = \pm 1$ of the affine line together.

figure: curve, not quite glued

In this example, the effect of normalization can be visualized geometrically. but this isn't always so. Normalization is an algebraic process, and its effect on geometry may be subtle. \square

4.3.4. Lemma. (i) *A unique factorization domain is normal. In particular, a polynomial algebra over a field is normal.*

(ii) *If s is a nonzero element of a normal domain A . The localization A_s is normal.*

(iii) *Let s_1, \dots, s_k be nonzero elements of a domain A that generate the unit ideal. If the localizations A_{s_i} are normal for all i , then A is normal.*

proof. (i) Let A be a unique factorization domain, and let β be an element of its fraction field that is integral over A . Say that

$$(4.3.5) \quad \beta^n + a_1\beta^{n-1} + \dots + a_{n-1}\beta + a_n = 0$$

with a_i in A . We write $\beta = r/s$, where r and s are relatively prime elements of A . Multiplying by s^n gives us the equation

$$r^n = -s(a_1r^{n-1} + \dots + a_n s^{n-1})$$

This equation shows that if a prime element of A divides s , it also divides r . Since r and s are relatively prime, there is no such prime element. So s is a unit, and β is in A .

(ii) Let β be an element of the fraction field of A that is integral over A_s . There will be a polynomial relation of the form (4.3.5), except that the coefficients a_i will be elements of A_s . The element $\gamma = s^k\beta$ satisfies the polynomial equation

$$\gamma^n + (s^k a_1)\gamma^{n-1} + \dots + (s^{(n-1)k} a_{n-1})\gamma + (s^{nk} a_n) = 0$$

Since a_i are in A_s , all coefficients in this polynomial equation will be in A when k is sufficiently large, and then γ will be integral over A . Since A is normal, γ will be in A , and $\beta = s^{-k}\gamma$ will be in A_s .

(iii) This proof follows a common pattern. Suppose that A_{s_i} is normal for every i . If an element β of K is integral over A , it will be in A_{s_i} for all i , and $s_i^n\beta$ will be an element of A when n is large. We can use the same exponent n for all i . Since s_1, \dots, s_k generate the unit ideal, so do their powers s_i^n, \dots, s_k^n . Say that $\sum r_i s_i^n = 1$, with r_i in A . Then $\beta = \sum r_i s_i^n \beta$ is in A . \square

It is convenient to state Theorem 4.3.1 more generally for the proof.

Let A be a finite type domain with fraction field K , and let L be a finite field extension of K . The *integral closure* of A in L is the set of all elements of L that are integral over A . Lemma 4.2.2 (ii) shows that the integral closure is a domain that contains A .

4.3.6. Theorem. *Let A be a finite type domain with fraction field K of characteristic zero, and let L be a finite field extension of K . The integral closure B of A in L is a finite A -module.*

4.3.7. Lemma. *Let A be a normal noetherian domain with fraction field K of characteristic zero, and let L be an algebraic field extension of K . An element β of L is integral over A if and only if the coefficients of the monic irreducible polynomial f for β over K are in A .*

proof. If the monic polynomial f has coefficients in A , then β is integral over A . Suppose that β is integral over A . Since we may replace L by any field extension that contains β , we may assume that L is a finite extension of K . A finite extension embeds into a Galois extension, so we may assume that L/K is a Galois extension. Let G be its Galois group, and let $\{\beta_1, \dots, \beta_r\}$ be the G -orbit of β , with $\beta = \beta_1$. The irreducible polynomial for β over K is

$$(4.3.8) \quad f(x) = (x - \beta_1) \cdots (x - \beta_r) \quad \text{orbitpoly}$$

Its coefficients are symmetric functions of the roots. If β is integral over A , then all elements of the orbit are integral over A . Therefore the symmetric functions are integral over A (4.2.2) (ii), and since A is normal, they are in A . So f has coefficients in A . \square

4.3.9. Example. A polynomial in $A = \mathbb{C}[x, y]$ is *square-free* if it has no nonconstant square factors and isn't a constant. Let $f(x, y)$ be a square-free polynomial, and let B denote the integral extension $\mathbb{C}[x, y, w]/(w^2 - f)$ of A . Let K and L be the fraction fields of A and B , respectively. Then $L = K[w]/(w^2 - f)$ is a Galois extension of K . Its Galois group is generated by the automorphism σ of order 2 defined by $\sigma(w) = -w$. The elements of L have the form $\beta = a + bw$ with $a, b \in K$, and $\sigma(\beta) = \beta' = a - bw$. dplanenormal

We show that B is the integral closure of A in L . Suppose that $\beta = a + bw$ is integral over A . If $b = 0$, then $\beta = a$. This is an element of A and therefore it is in B . If $b \neq 0$, the irreducible polynomial for β will be

$$(x - \beta)(x - \beta') = x^2 - 2ax + (a^2 - b^2f)$$

Because β is integral over A , $2a$ and $a^2 - b^2f$ are in A . Because the characteristic isn't 2, this is true if and only if a and b^2f are in A . We write $b = u/v$, with u, v relatively prime elements of A , so $b^2f = u^2f/v^2$. If v weren't a constant, then since f is square-free, it couldn't cancel v^2 . So from b^2f in A we can conclude that v is a constant and that b is in A . Summing up, β is integral if and only if a and b are in A , which means that β is in B . \square

(4.3.10) trace deftrace

Let L be a finite field extension of a field K and let β be an element of K . When L is viewed as a K -vector space, multiplication by β becomes a linear operator $L \xrightarrow{\beta} L$. The *trace* of this operator will be denoted by $\text{tr}(\beta)$. The trace is a K -linear map $L \rightarrow K$.

4.3.11. Lemma. Let L/K be a finite field extension, let β be an element of L of degree r over K , let $f(x) = x^r + a_1x^{r-1} + \cdots + a_r$ be its irreducible polynomial over K , and let $K(\beta)$ be the extension of K generated by β . Say that $[L : K(\beta)] = d$ and $[L : K] = n (= rd)$. Then $\text{tr}(\beta) = -da_1$. If β is an element of K , then $\text{tr}(\beta) = n\beta$. about-traceone

proof. The set $(1, \beta, \dots, \beta^{r-1})$ is a K -basis for $K(\beta)$. On this basis, the matrix M of multiplication by β has the form illustrated below for the case $r = 3$. Its trace is $-a_1$.

$$M = \begin{pmatrix} 0 & 0 & -a_3 \\ 1 & 0 & -a_2 \\ 0 & 1 & -a_1 \end{pmatrix}.$$

Next, let (u_1, \dots, u_d) be a basis for L over $K(\beta)$. Then $\{\beta^i u_j\}$, with $i = 0, \dots, r - 1$ and $j = 1, \dots, d$, will be a basis for L over K . When this basis is listed in the order

$$(u_1, u_1\beta, \dots, u_1\beta^{r-1}; u_2, u_2\beta, \dots, u_2\beta^{r-1}; \dots; u_d, u_d\beta, \dots, u_d\beta^{r-1}),$$

the matrix of multiplication by β will be made up of d blocks of the matrix M . \square

4.3.12. Corollary. Let A be a normal domain with fraction field K and let L be a finite field extension of K . If an element β is integral over A , its trace is in A . traceinA

This follows from Lemmas 4.3.7 and 4.3.11. □

formnon-
deg

4.3.13. Lemma. *Let A be a normal noetherian domain with fraction field K of characteristic zero, and let L be a finite field extension of K . The form $L \times L \rightarrow K$ defined by $\langle \alpha, \beta \rangle = \text{tr}(\alpha\beta)$ is K -bilinear, symmetric, and nondegenerate. If α and β are integral over A , then $\langle \alpha, \beta \rangle$ is an element of A .*

proof. The form is obviously symmetric, and it is K -bilinear because multiplication is K -bilinear and trace is K -linear. A form is nondegenerate if its nullspace is zero, which means that when α is a nonzero element, there is an element β such that $\langle \alpha, \beta \rangle \neq 0$. Let $\beta = \alpha^{-1}$. Then $\langle \alpha, \beta \rangle = \text{tr}(1)$, which, according to (4.3.11), is the degree $[L : K]$ of the field extension. It is here that the hypothesis on the characteristic of K enters: The degree is a nonzero element of K .

If α and β are integral over A , so is their product $\alpha\beta$ (4.2.2) (ii). Corollary 4.3.12 shows that $\langle \alpha, \beta \rangle$ is an element of A . □

clearde-
nom

4.3.14. Lemma. *Let A be a domain with fraction field K , let L be a field extension of K , and let β be an element of L that is algebraic over K . If β is a root of a polynomial $f = a_n x^n + a_{n-1} x^{n-1} + \cdots + a_0$ with a_i in A , then $\gamma = a_n \beta$ is integral over A .*

proof. One finds a monic polynomial with root γ by substituting $x = y/a_n$ into f and multiplying by a_n^{n-1} . □

proof of Theorem 4.3.1. Let A be a finite-type domain with fraction field K of characteristic zero, and let L be a finite field extension of K . We are to show that the integral closure of A in L is a finite A -module.

Step 1. We may assume that A is normal.

We use the Noether Normalization Theorem to write A as a finite module over a polynomial subalgebra $R = \mathbb{C}[y_1, \dots, y_d]$. Let F be the fraction field of R . Then K and L are finite extensions of F . An element of L will be integral over A if and only if it is integral over R ((4.2.2) (iv)). So the integral closure of A in L is the same as the integral closure of R in L . We replace A by the normal algebra R and K by F .

Step 2. Bounding the integral extension.

We assume that A is normal. Let (v_1, \dots, v_n) be a K -basis for L whose elements are integral over A . Such a basis exists because we can multiply any element of L by a nonzero element of K to make it integral (Lemma 4.3.14). Let

mapvector

$$(4.3.15) \quad T : L \rightarrow K^n$$

be the map defined by $T(\beta) = (\langle v_1, \beta \rangle, \dots, \langle v_n, \beta \rangle)$, where $\langle \cdot, \cdot \rangle$ is the bilinear form defined in Lemma 4.3.13. This map is K -linear. If $\langle v_i, \beta \rangle = 0$ for all i , then because (v_1, \dots, v_n) is a basis for L , $\langle \gamma, \beta \rangle = 0$ for all γ in L , and since the form is nondegenerate, $\beta = 0$. Therefore T is injective.

Let B be the integral closure of A in L . The basis elements v_i are in B , and if β is in B , $v_i \beta$ will be in B too. Then $\langle v_i, \beta \rangle = \text{tr}(v_i \beta)$ will be in A , and $T(\beta)$ will be in A^n (4.3.13). When we restrict T to B , we obtain an injective map $B \rightarrow A^n$ that we denote by T_0 . Since T is K -linear, T_0 is A -linear. It is an injective homomorphism of A -modules that maps B isomorphically to its image, a submodule of A^n . Since A is noetherian, every submodule of the finite A -module A^n is finitely generated. Therefore the image of T_0 is a finite A -module, and so is the isomorphic module B . □

Section 4.4 Geometry of Integral Morphisms

prmint

The main geometric properties of an integral morphism of affine varieties are summarized in the theorems in this section, which show that the geometry is as nice as could be expected.

Let $Y \xrightarrow{u} X$ be an integral morphism. A closed subvariety D of Y lies over a closed subvariety C of X if C is the image of D .

We translate this definition to algebra: Let $A \subset B$ be an extension of finite-type domains. As before, if I is an ideal of A , the *extended* ideal IB is the ideal of B generated by I , whose elements are finite sums $\sum u_i b_i$ with u_i in I and b_i in B . The *contraction* of an ideal J of B is the ideal $J \cap A$ of A . The contraction of a prime ideal is a prime ideal.

Closed subvarieties of the affine variety $X = \text{Spec } A$ correspond bijectively to prime ideals of A . In analogy with the terminology for closed subvarieties, we say that a prime ideal Q of B lies over a prime ideal P of A if P is the contraction $Q \cap A$. For example, if a point y of $Y = \text{Spec } B$ has image x in X , the maximal ideal \mathfrak{m}_y lies over the maximal ideal \mathfrak{m}_x .

4.4.1. Proposition. Let $A \rightarrow B$ be an integral extension, and let $X = \text{Spec } A$ and $Y = \text{Spec } B$.

QoverP

- (i) The morphism $Y \rightarrow X$ defined by the inclusion $A \rightarrow B$ is surjective.
- (ii) Let P and Q be prime ideals of A and B , respectively, and let $C = V_X(P) = \text{Spec } A/P$ and $D = V_Y(Q) = \text{Spec } B/Q$. Then Q lies over P if and only if D lies over C .

proof. (i) Let \mathfrak{m}_x be the maximal ideal at point x of X . Corollary 4.1.5 (ii) shows that the extended ideal $\mathfrak{m}_x B$ isn't the unit ideal of B , so it is contained in a maximal ideal of B , say \mathfrak{m}_y , where y is a point of Y , and then x is the image of y . Therefore u is surjective.

(ii) Suppose that Q lies over P , i.e., that $P = Q \cap A$. Let $\bar{A} = A/P$ and $\bar{B} = B/Q$. The canonical map $\bar{A} \rightarrow \bar{B}$ is injective, and \bar{B} is generated as \bar{A} -module by the residues of a set of generators of the finite A -module B , so \bar{B} is a finite \bar{A} -module – an integral extension of \bar{A} . By (i), $\text{Spec } \bar{B} = D$ maps surjectively to $\text{Spec } \bar{A} = C$, which means that D lies over C . Conversely, if D lies over C , the morphism $D \xrightarrow{\varphi} C$ gives us a map $\bar{A} \rightarrow \bar{B}$, and since $D \rightarrow C$ is surjective, that map is injective. This implies that $P = Q \cap A$. \square

4.4.2. Theorem. Let $Y \xrightarrow{u} X$ be an integral morphism of affine varieties.

closedim-age

- (i) The fibres of the morphism u have bounded cardinality.
- (ii) The image of a closed subset of Y is a closed subset of X , and the image of a closed subvariety of Y is a closed subvariety of X .
- (iii) The set of closed subvarieties of Y that lie over a closed subvariety of X is nonempty.

proof. Let $Y \xrightarrow{u} X$ be the integral morphism, $Y = \text{Spec } B$ and $X = \text{Spec } A$, that corresponds to the inclusion $A \subset B$.

(i) (*bounding the fibres*) Let y_1, \dots, y_r be the points of Y in the fibre over a point x of X . For each i , the maximal ideal \mathfrak{m}_x of A is the contraction of the maximal ideal \mathfrak{m}_{y_i} of B . To bound the number r , we use the Chinese Remainder Theorem to show that B cannot be spanned as A -module by fewer than r elements.

Let k_i and k denote the residue fields B/\mathfrak{m}_{y_i} , and A/\mathfrak{m}_x , respectively, all of these fields being isomorphic to \mathbb{C} . Let $\bar{B} = k_1 \times \dots \times k_r$. We form a diagram of algebra homomorphisms

$$\begin{array}{ccc} B & \xrightarrow{\varphi} & \bar{B} \\ \uparrow & & \uparrow \\ A & \longrightarrow & k \end{array}$$

which we interpret as a diagram of A -modules. The minimal number of generators of the A -module \bar{B} is equal to its dimension as k -module, which is r . The Chinese Remainder Theorem asserts that φ is surjective, so B cannot be spanned by fewer than r elements.

(ii) (*the image of a closed set is closed*) The image of an irreducible set via a continuous map is irreducible. This is easy to see. So it suffices to show that the image of a closed subvariety is closed. Let D be the closed subvariety of Y that corresponds to a prime ideal Q of B , and let $P = Q \cap A$ be its contraction, which is a prime ideal of A . Let C be the variety of zeros of P in X . The coordinate algebras of the affine varieties D and C are $\bar{B} = B/Q$ and $\bar{A} = A/P$, respectively, and because B is an integral extension of A , \bar{B} is an integral extension of \bar{A} . By (4.4.1) (i), the map $D \rightarrow C$ is surjective. Therefore C is the image of D .

(iii) (*subvarieties that lie over a closed subvariety*) The inverse image $Z = u^{-1}C$ of a closed subvariety C is closed in Y . It is the union of finitely many irreducible closed subsets, say $Z = D'_1 \cup \dots \cup D'_k$. Part (i) tells us that the image C'_i of D'_i is a closed subvariety of X . Since u is surjective, $C = \bigcup C'_i$, and since C is irreducible, it is equal to at least one C'_i . \square

(4.4.3) finite group actions

grpai

Let G be a finite group of automorphisms of a normal, finite-type domain B , let A be the algebra B^G of invariant elements of B , and let $Y = \text{Spec } B$ and $X = \text{Spec } A$. According to Theorem 2.8.5, A is a finite-type domain, B is a finite A -module, and points of X correspond to G -orbits of points of Y .

invariant-
denom

4.4.4. Lemma. Let G be a finite group of automorphisms of a normal, finite-type domain B and let A be the subalgebra of invariant elements. Let L and K be the fraction fields of B and A , respectively.

- (i) The algebra A is normal, an B is an integral extension of A .
- (ii) Every element of L can be written as a fraction b/s , with b in B , and s in A .
- (iii) L is a Galois extension of K , with Galois group G . The ring of G -invariants L^G is K . □

We go back briefly to an integral morphism. The next theorem concerns inclusions among closed subvarieties. It refers to the diagram below:

$$\begin{array}{ccc} D' \subset D & & Y \\ C' \subset C & & X \end{array}$$

integral-
properties

4.4.5. Theorem. Let $Y \xrightarrow{u} X$ be an integral morphism of affine varieties, and let $C' \subset C$ be closed subvarieties of X .

- (i) Every closed subvariety D of Y that lies over C contains a closed subvariety D' that lies over C' .
- (ii) Suppose that X normal. Every closed subvariety D' of Y that lies over C' is contained in a closed subvariety D that lies over C .

As is indicated by the fact that X is assumed normal in (ii), that property is more subtle than (i). We omit the proof of the theorem, which we won't use. But study the next example, which shows that the hypothesis of normality cannot be dropped from (ii). It is good for ones understanding.

downfalse

4.4.6. Example. In the affine plane $Y = \text{Spec } \mathbb{C}[u, v]$, let L_1 and L_2 be the lines $v = 1$ and $v = -1$, respectively, let D be the diagonal line $u = v$, and let D' be the point $(-1, 1)$. We form an affine variety X by gluing L_1 to L_2 , identifying the points $(u, 1)$ and $(u, -1)$. You can work out its coordinate algebra. Let $Y \xrightarrow{\pi} X$ be the gluing map. The real loci of Y and X are depicted below. In the figure, C is the image of D , and C' is the image of D' . Here C' is contained in C , but because D is the only subvariety of Y that lies over C , there is no variety that lies over C which contains D' . □

gluing-
plane

4.4.7.

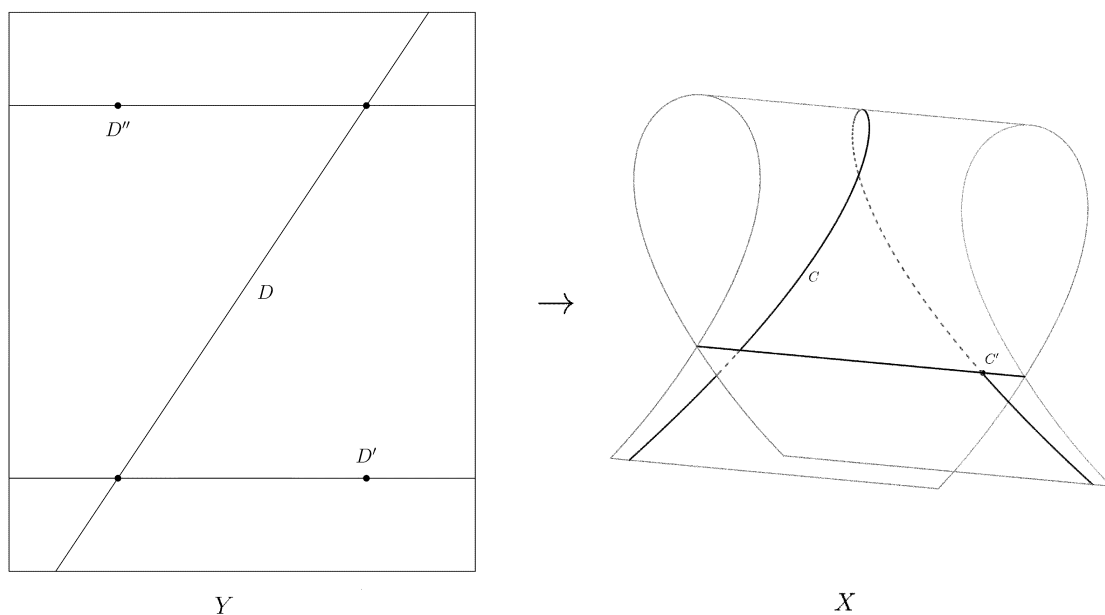

Gluing of a Plane Along Two Lines (real locus)

Section 4.5 Dimension

Every variety has a dimension, and, as with the dimension of a vector space, the dimension of a variety is important, though it is a very coarse measure. dim

There are two equivalent definitions of dimension of a variety X , though the proof that they are equal requires work. One definition is as the transcendence degree of the function field of X . For now, we'll refer to it as the *t-dimension* of X .

The alternative definition of dimension might be called its *combinatorial dimension*. It is defined as follows: A *chain* of closed subvarieties of a variety X is a strictly decreasing sequence of closed subvarieties (of irreducible closed subsets)

$$(4.5.1) \quad C_0 > C_1 > C_2 > \cdots > C_k$$
chntwo

The *length* of this chain is defined to be k . The chain is *maximal* if it cannot be lengthened by inserting another closed subvariety, which means that $C_0 = X$, that there is no closed subvariety \tilde{C} with $C_i > \tilde{C} > C_{i+1}$ for $i < k$, and that C_k is a point.

Theorem 4.5.6 below shows that all maximal chains of closed subvarieties have the same length. The combinatorial dimension of X is the length of a maximal chain. For now, we'll denote the combinatorial dimension of a variety by its *c-dimension*. Theorem 4.5.6 also shows that the t-dimension and the c-dimension of a variety are equal. When we have proved the theorem, we will refer to the t-dimension and to the c-dimension simply as the *dimension*, and we will use the two definitions interchangeably. In the meantime, we will denote the t-dimension of a variety X by $\dim X$, and we will continue to use this notation for the dimension when Theorem 4.5.6 has been proved.

Recall that the transcendence degree of a domain A is equal to the transcendence degree of its fraction field (1.5.1). So the t-dimension of an affine variety $X = \text{Spec } A$ is also equal to the transcendence degree of its coordinate algebra A .

In an affine variety $\text{Spec } A$, the decreasing chain (4.5.1) corresponds to an increasing chain

$$(4.5.2) \quad P_0 < P_1 < P_2 < \cdots < P_k,$$
chn

of prime ideals of A of length k , a *prime chain*. This prime chain is *maximal* if it cannot be lengthened by inserting another prime ideal, which means that P_0 is the zero ideal, that there is no prime ideal \tilde{P} with $P_i < \tilde{P} < P_{i+1}$ for $i < k$, and that P_k is a maximal ideal. The *c-dimension* $\dim A$ of a finite-type domain A is the length k of a maximal chain (4.5.2) of prime ideals. If $X = \text{Spec } A$, then the c-dimensions of X and of A are equal.

The next theorem is the basic tool for studying dimension, Its statement is intuitively plausible, though the proof isn't easy

4.5.3. Krull's Principal Ideal Theorem. Let X be an affine variety of t-dimension d , and let α be a nonzero element of its coordinate algebra A . Every irreducible component C of the zero locus $V_X(\alpha)$ of α in X has t-dimension $d - 1$. krullthm

4.5.4. Corollary. Let X be an affine variety of t-dimension d , and let C be a component of the zero locus of a nonzero element α of its coordinate algebra A . Then C is a maximal proper closed subvariety. There is no closed subvariety D such that $C < D < X$. compmax

proof. Let D be a proper closed subvariety of X . Some nonzero element β of A will vanish on D . Then D will be a subvariety of the zero locus of β , and by Krull's Theorem, its t-dimension will be at most $d - 1$.

Suppose that C is a proper closed subvariety of D . Then, when we replace X and D by D and C and reason as above, we find that the t-dimension of C will be at most $d - 2$. □

proof of Krull's Theorem.

Step 1. The case of an affine space, $X = \text{Spec } \mathbb{C}[x_1, \dots, x_d]$.

The irreducible components of the zero locus of α are the zero sets of the irreducible factors of α . We replace α by the irreducible factor that vanishes on C . Then $V_X(\alpha) = C$, and the coordinate algebra of C is $\bar{A} = A/A\alpha$. Next, we choose a transcendence basis $\alpha_1, \dots, \alpha_d$ of A , with $\alpha_d = \alpha$ (1.5.1). Let $\bar{\alpha}_i$ be the

residue of α_i in \bar{A} , for $i = 1, \dots, d - 1$. To show that the t-dimension of C is $d - 1$, we show that $\bar{\alpha}_1, \dots, \bar{\alpha}_{d-1}$ is a transcendence basis of \bar{A} .

We first show that every element of \bar{A} is algebraic over the ring $\bar{R} = \mathbb{C}[\bar{\alpha}_1, \dots, \bar{\alpha}_{d-1}]$. Let $\bar{\beta}$ be an element of \bar{A} that is represented by an element β of A . Then β is algebraic over the field of rational functions $\mathbb{C}(\alpha) = \mathbb{C}(\alpha_1, \dots, \alpha_d)$. Let $f(t) = \sum c_i t^i$ be a polynomial with coefficients c_i in $\mathbb{C}(\alpha)$ that has β as root. We may clear denominators, so we may assume that c_i are in the ring $R = \mathbb{C}[\alpha_1, \dots, \alpha_d]$, and that c_i aren't all divisible by α_d . Then the residues \bar{c}_i of c_i in \bar{A} aren't all zero, so the residue \bar{f} of f isn't the zero polynomial. But $\bar{\beta} = \bar{f}(\bar{\alpha}_1, \dots, \bar{\alpha}_{d-1}) = 0$. So $\bar{\beta}$ is algebraic over \bar{R} .

Next, let $g(z_1, \dots, z_{d-1})$ be a nonzero polynomial with coefficients in \mathbb{C} such that $g(\bar{\alpha}_1, \dots, \bar{\alpha}_{d-1}) = 0$. Then $g(\alpha_1, \dots, \alpha_{d-1}) \equiv 0$, modulo α_d . There is a polynomial $h(z_1, \dots, z_d)$ with coefficients in \mathbb{C} such that $g(\alpha_1, \dots, \alpha_{d-1}) = \alpha_d h(\alpha_1, \dots, \alpha_d)$. The polynomial $g(z_1, \dots, z_{d-1}) - z_d h(z_1, \dots, z_d)$ isn't zero, but it evaluates to zero when α is substituted for z . This contradicts the fact that $\alpha_1, \dots, \alpha_d$ are algebraically independent.

Step 2. Reduction to the case that A is normal.

We go back to the case of an affine variety $X = \text{Spec } A$ of t-dimension d and an irreducible component C of the zero locus of a nonzero element α of A . We are to show that the t-dimension of C is $d - 1$.

Let B be the normalization of A and let $Y = \text{Spec } B$. The t-dimension of Y is d . The integral morphism $Y \rightarrow X$ is surjective, and it sends closed sets to closed sets (4.4.2). The zero locus $V_Y(\alpha)$ of α in Y is the inverse image of $V_X(\alpha)$, so the map $V_Y(\alpha) \rightarrow V_X(\alpha)$ is surjective.

Let D_1, \dots, D_k be the irreducible components of $V_Y(\alpha)$, and let C_i be the image of D_i in X . The closed sets C_i are irreducible ((4.4.2) (ii)), and $V_X(\alpha)$ is their union. So at least one C_i is equal to C . Let D be a component of $V_Y(\alpha)$ whose image is C . The map $D \rightarrow C$ is also an integral morphism, so the t-dimension of D is the same as that of C . We may therefore replace X and C by Y and D , respectively. Hence we may assume that A is normal.

Step 3. Reduction to the case that the zero locus of α is irreducible.

We do this by localizing. Suppose that the zero locus of α is $C \cup V$, where C is our irreducible component, and that V is the union of the other irreducible components. We choose an element s of A that is identically zero on V but not identically zero on C . Inverting s eliminates the points of V , but $X_s \cap C = C_s$ will be nonempty. If X is normal, so is X_s . Since localization doesn't change the t-dimension, we may replace X and C by X_s and C_s , respectively.

Step 4. Completion of the proof.

Now X is normal, and the irreducible closed set C is the zero locus of α in X . We apply the Noether Normalization Theorem. Let $X \rightarrow S$ be an integral morphism to an affine space $S = \text{Spec } R$ of dimension d , where R is the polynomial ring $\mathbb{C}[x_1, \dots, x_d]$. Let K and F be the function fields of X and S , respectively, and let L be a Galois extension of F that contains K . Also, let B be the integral closure of A in L , and let $Y = \text{Spec } B$. Then Y is an integral extension of S and of X . The Galois group G of L/F operates on B and on Y . and R is the algebra B^G of invariants. We have a diagram of morphisms

$$\begin{array}{ccc} Y & \xrightarrow{u} & X \\ v \downarrow & & \downarrow w \\ S & \xlongequal{\quad} & S \end{array}$$

with $v = wu$.

Let $\alpha_1, \dots, \alpha_r$ be the orbit of α , with $\alpha = \alpha_1$, and let $f(x) = (x - \alpha_1) \cdots (x - \alpha_r)$. Its coefficients are invariant. They are elements of R , and the constant term is the product $\beta = \prod_i \alpha_i$. In A , $x - \alpha$ divides $f(x)$, and therefore α divides β .

The element β defines functions on Y , X , and Z . If β denotes the function on S , the functions on Y and X are the compositions βv and βw , respectively. But let's denote all of those functions by β . Similarly, α defines functions on X and Y that we denote by α .

image of C

4.5.5. Lemma. *With notation as above, the zero locus Z of β in the affine space S is the image wC of C .*

proof. Let x be a point of C , so $\alpha(x) = 0$. Since α divides β , $\beta(x) = 0$. If $s = wx$ is the image of x in S , then $\beta(s) = \beta(x)$. So $\beta(s) = 0$, which shows that s is a point of Z . So Z contains the image of C .

For the other inclusion, let s be a point of Z . So $\beta(s) = 0$. Let y be a point of Y that lies over s : $vy = s$. The fibre of Y over s is the G -orbit of y (2.8.5), and β vanishes at every point of this orbit. Since $\beta = \prod \alpha_i$, $\alpha_i(y) = 0$ for some i . Say that $\alpha_i = \sigma\alpha$. Then since $[\sigma\alpha](y) = \alpha(y\sigma)$ (2.8.8), $\alpha(y\sigma) = 0$. We replace y by $y\sigma$. Then $\alpha(y) = 0$, and it is still true that $vy = s$.

Let x be the image of y in X : $x = uy$. Since $v = wu$, the image of x in S is s . Since α is an element of A , its zero set in Y is the inverse image of its zero set in X . So, since $\alpha(y) = 0$, we also have $\alpha(x) = 0$. This shows that x is a point of C that maps to s . Therefore the map $C \rightarrow Z$ is surjective. \square

Going back to the proof of Step 4 of Krull's Theorem, the image Z of the surjective map $C \rightarrow Z$ is irreducible because C is irreducible, so it is a variety. Since $X \rightarrow S$ is an integral morphism, so is the map $C \rightarrow Z$. Therefore C and Z have the same t-dimension. Moreover, Z is the zero set of the function β . Step 1 tells us that the t-dimension of Z is $d - 1$. So C has t-dimension $d - 1$. This completes the proof. \square

4.5.6. Theorem. *Let X be a variety of t-dimension d . All chains of closed subvarieties of X have length at most d , and all maximal chains have length d . Therefore the c-dimension and the t-dimension of X are equal.*

dimtheorem

proof. We treat the case of an affine variety first.

Induction allows us to assume that the theorem is true for a variety whose t-dimension is less than d . Let $X = \text{Spec } A$ be an affine variety of t-dimension d . $C_0 > C_1 > \dots > C_k$ be a chain of closed subvarieties of X . We must show that $k \leq d$ and that, if the chain is maximal, then $k = d$. We may insert closed subvarieties into the chain where possible, so we may assume that $C_0 = X$. Next, C_1 , being a proper closed subset of X , is contained in the zero locus Z of a nonzero element α of A , and it will be contained in some irreducible component \tilde{C} of Z . If $\tilde{C} > C_1$, we insert \tilde{C} into the chain, to reduce ourselves to the case that C_1 is a component of the zero locus of α . By Krull's Theorem, C_1 has t-dimension $d - 1$. By Corollary 4.5.4 it is a maximal proper closed subvariety, and induction applies to the chain $C_1 > \dots > C_k$ of closed subvarieties of C_1 . It shows that the length of that chain, which is $k - 1$ is less than $d - 1$, and it is equal to $d - 1$ if the chain is maximal. Therefore the chain $\{P_i\}$ has length at most n , and it has length n if it is a maximal chain.

Theorem 4.5.6 in the general case follows from the next lemma. \square

4.5.7. Lemma. *Let X' be an open subvariety of a variety X . There is a bijective correspondence between chains $C_0 > \dots > C_k$ of closed subvarieties of a variety X such that $C_k \cap X' \neq \emptyset$ and chains $C'_0 > \dots > C'_k$ of closed subvarieties of X' , defined by $C'_i = C_i \cap X'$. Given a chain C'_i in X' , the corresponding chain in X consists of the closures C_i in X of the varieties C'_i .*

re-strictchain

proof. Suppose given a chain C_i and that $C_k \cap X' \neq \emptyset$. Then the intersection $C'_i = C_i \cap X'$ is a dense open subset of the irreducible closed set C_i (2.2.14). So the closure of C'_i is C_i , and since $C_i > C_{i+1}$, it is also true that $C'_i > C'_{i+1}$. Therefore $C'_0 > \dots > C'_k$ is a chain of closed subsets of X' . Conversely, if $C'_0 > \dots > C'_k$ is a chain in X' , the closures in X form a chain in X . \square

For example, the transcendence degree of the polynomial algebra $\mathbb{C}[x_0, \dots, x_n]$ in $n+1$ variables is $n+1$. The polynomial algebra has dimension $n+1$. The chain of prime ideals

$$(4.5.8) \quad 0 < (x_0) < (x_0, x_1) < \dots < (x_0, \dots, x_n)$$

is a maximal prime chain. When the irrelevant ideal (x_0, \dots, x_n) is removed from this chain, it corresponds to a maximal chain

primechain

$$\mathbb{P}^n > \mathbb{P}^{n-1} > \dots > \mathbb{P}^0$$

of closed subvarieties of projective space \mathbb{P}^n , which has c-dimension n .

The maximal chains of closed subvarieties of \mathbb{P}^2 have the form $\mathbb{P}^2 > C > p$, where C is a plane curve and p is a point.

If (4.5.1) is a maximal chain in X , then $C_0 = X$, and

$$(4.5.9) \quad C_1 > C_2 > \dots > C_k$$

chaini

will be a maximal chain in the variety C_1 . So when X has dimension k , the dimension of C_1 is $k-1$. Similarly, let (4.5.2) be a maximal chain of prime ideals in a finite-type domain A , let $\bar{A} = A/P_1$ and let \bar{P}_j denote the image P_j/P_1 of P_j in \bar{A} , for $j \geq 1$. Then

$$\bar{0} = \bar{P}_1 < \bar{P}_2 < \dots < \bar{P}_k$$

will be a maximal prime chain in \overline{A} , and therefore the dimension of the domain \overline{A} is $k-1$. There is a bijective correspondence between maximal prime chains in \overline{A} and maximal prime chains in A whose first term is P_0 .

One more term: A closed subvariety C of a variety X has *codimension 1* if $C < X$ and if there is no closed set \tilde{C} with $C < \tilde{C} < X$. A prime ideal P of a noetherian domain has *codimension 1* if it is not the zero ideal, and if there is no prime ideal \tilde{P} with $(0) < \tilde{P} < P$. In the polynomial algebra $\mathbb{C}[x_1, \dots, x_n]$, the prime ideals of codimension 1 are the principal ideals generated by irreducible polynomials.

inte-
graldime-
qual

4.5.10. Corollary. *Let X be a variety.*

(i) *If X' is an open subvariety of a X , then $\dim X' = \dim X$.*

(ii) *If Y is a proper closed subvariety of X , then $\dim Y < \dim X$.*

(iii) *If $Y \rightarrow X$ is an integral morphism of varieties, then $\dim Y = \dim X$.* □

Section 4.6 Chevalley's Finiteness Theorem

finmorph
prodagain

(4.6.1) finite morphisms

The concepts of a finite morphism and an integral morphism of affine varieties were defined in Section 4.2. A morphism $Y \xrightarrow{u} X$ of affine varieties $X = \text{Spec } A$ and $Y = \text{Spec } B$ is a finite morphism if the homomorphism $A \xrightarrow{\varphi} B$ that corresponds to u makes B into a finite A -module. As was noted before, the difference between a finite morphism and an integral morphism of affine varieties is that for a finite morphism, the homomorphism φ needn't be injective. If φ is injective, B will be an integral extension of A , and u will be an integral morphism.

We extend these definitions to varieties that aren't necessarily affine here. By the *restriction* of a morphism $Y \xrightarrow{u} X$ to an open subset X' of X , we mean the induced morphism $Y' \rightarrow X'$, where Y' is the inverse image of X' .

deffin-
morph

4.6.2. Definition. A morphism of varieties $Y \xrightarrow{u} X$ is a *finite morphism* if X can be covered by affine open subsets X^i such that the restriction of u to each X^i is a finite morphism of affine varieties, as defined in (4.2.4). A morphism u is an *integral morphism* if X can be covered by affine open sets to which the restriction of u is an integral morphism of affine varieties.

finiteex-
amp

4.6.3. Corollary. *An integral morphism is a finite morphism. The composition of finite morphisms is a finite morphism. The inclusion of a closed subvariety into a variety is a finite morphism.* □

When X is affine, Definition 4.2.4 and Definition 4.6.2 both apply. The next proposition shows that the two definitions are equivalent.

onecov-
erfinite

4.6.4. Proposition. *Let $Y \xrightarrow{u} X$ be a finite or an integral morphism, as defined in (4.6.2), and let X' be an affine open subset of X . The restriction of u to X' is a finite or an integral morphism of affine varieties, as was defined in (4.2.4).*

restfin-
morph

4.6.5. Lemma. (i) *Let $A \xrightarrow{\varphi} B$ be a homomorphism of finite-type domains that makes B into a finite A -module, and let s be a nonzero element of A . Then B_s is a finite A_s -module.*

(ii) *The restriction of a finite (or an integral) morphism $Y \xrightarrow{u} X$ to an open subset of X is a finite (or an integral) morphism.*

proof. (i) In the statement, B_s denotes the localization of B as A -module. This localization can also be obtained by localizing the algebra B with respect to the image $s' = \varphi(s)$, provided that it isn't zero. If s' is zero, then s annihilates B , so $B_s = 0$. In either case, a set of elements that spans B as A -module will span B_s as A_s -module, so B_s is a finite A_s -module.

(ii) Say that X is covered by affine open sets to which the restriction of u is a finite morphism. The localizations of these open sets form a basis for the Zariski topology on X . So X' can be covered by such localizations. Part (i) shows that the restriction of u to X' is a finite morphism. □

proof of Proposition 4.6.4. We'll do the case of a finite morphism. The proof isn't difficult, but there are several things to check, and this makes the proof longer than one would like.

Step 1. Preliminaries.

We are given a morphism $Y \xrightarrow{u} X$, X is covered by affine open sets X^i , and the restrictions of u to these open sets are finite morphisms of affine varieties. We are to show that the restriction to any affine open set X' is a finite morphism of affine varieties.

The affine open set X' is covered by the affine open sets $X'^i = X' \cap X^i$, and the restrictions to X'^i are finite morphisms ((4.6.5) (ii)). So we may replace X by X' . Since the localizations of an affine variety form a basis for its Zariski topology, we see that what is to be proved is this:

A morphism $Y \xrightarrow{u} X$ is given in which $X = \text{Spec } A$ is affine. There are elements s_1, \dots, s_k that generate the unit ideal of A , such that for every i , the inverse image Y^i of $X^i = X_{s_i}$ if nonempty, is affine, and its coordinate algebra B_i is a finite module over the localized algebra $A_i = A_{s_i}$. We must show that Y is affine, and that its coordinate algebra B is a finite A -module.

Step 2. The algebra B of regular functions on Y .

We assume that X is affine. If Y is affine, its coordinate algebra B will be a finite-type domain, and Y will be its spectrum. Since Y isn't assumed to be affine, we don't know very much about the algebra B other than that it is a subalgebra of the function field of Y . By hypothesis, the inverse image Y^i of X^i , if nonempty, is affine, the spectrum of a finite A_i -algebra B_i . Since the localizations X^i cover X , the affine varieties the Y^i cover Y . We throw out the indices i such that Y^i is empty. Then a function is regular on Y if and only if it is regular on each Y^i , and

$$B = \bigcap B_i$$

the intersection being in the function field of Y .

Let's denote the images in B of the elements s_i of A by the same symbols.

Step 3. For any index j , B_j is the localization $B[s_j^{-1}]$ of B .

The intersection $Y^j \cap Y^i$ is an affine variety. It is the set of points of the affine variety $Y^j = \text{Spec } B_j$ at which s_i isn't zero. So its coordinate algebra is the localization $B_j[s_i^{-1}]$. Then

$$B[s_j^{-1}] \stackrel{(1)}{=} \bigcap_i (B_i[s_j^{-1}]) \stackrel{(2)}{=} \bigcap_i B_j[s_i^{-1}] \stackrel{(3)}{=} B_j[s_j^{-1}] \stackrel{(3)}{=} B_j$$

where the explanation of the numbered equalities is as follows:

- (1) A rational function β is in $B_i[s_j^{-1}]$ if $s_j^n \beta$ is in B_i for large n , and we can use the same exponent n for all $i = 1, \dots, r$. Then β is in $\bigcap_i (B_i[s_j^{-1}])$ if and only if $s_j^n \beta$ is in $\bigcap_i B_i = B$, i.e., if and only if β is in $B[s_j^{-1}]$.
- (2) $B_i[s_j^{-1}] = B_j[s_i^{-1}]$ because $Y^j \cap Y^i = Y^i \cap Y^j$.
- (3) For all i , $B_j \subset B_j[s_i^{-1}]$. Moreover, s_j doesn't vanish on Y^j . It is a unit in B_j , and therefore $B_j[s_i^{-1}] = B_j$. Then $B_j \subset \bigcap_i B_j[s_i^{-1}] \subset B_j[s_j^{-1}] = B_j$.

Step 4. B is a finite A -module.

We choose a finite set (b_1, \dots, b_n) of elements of B that generates the A_i -module B_i for every i . We can do this because we can span the finite A_i -module $B_i = B[s_i^{-1}]$ by finitely many elements of B , and there are finitely many algebras B_i . We show that the set (b_1, \dots, b_n) generates the A -module B .

Let x be an element of B . Since x is in B_i , it is a combination of the elements (b_1, \dots, b_n) with coefficients in A_i . Then for large k , $s_i^k x$ will be a combination of those elements with coefficients in A , say

$$s_i^k x = \sum_{\nu} a_{i,\nu} b_{\nu}$$

with $a_{i,\nu}$ in A . We can use the same exponent k for all i . Then with $\sum r_i s_i^k = 1$,

$$x = \sum_i r_i s_i^k x = \sum_i r_i \sum_{\nu} a_{i,\nu} b_{\nu}$$

The right side is a combination of b_1, \dots, b_n with coefficients in A .

Step 5. Y is affine.

The algebra B of regular functions on Y is a finite-type domain because it is a finite module over the finite-type domain A . Let $\tilde{Y} = \text{Spec } B$. The fact that B is the algebra of regular functions on Y gives us a morphism $Y \xrightarrow{\epsilon} \tilde{Y}$ (Corollary 3.6.2). Restricting to the open subset X^j of X gives us a morphism $Y^j \xrightarrow{\epsilon^j} \tilde{Y}^j$ in which Y^j and \tilde{Y}^j are both equal to $\text{Spec } B_j$. Therefore ϵ^j is an isomorphism. Corollary 3.5.14 (ii) shows that ϵ is an isomorphism. So Y is affine and by Step 4, its coordinate algebra B is a finite A -module. \square

We come to Chevalley's theorem now. Let \mathbb{P} denote the projective space \mathbb{P}^n with coordinates y_0, \dots, y_n .

chevfin

4.6.6. Chevalley's Finiteness Theorem. *Let X be a variety, let Y be a closed subvariety of the product $\mathbb{P} \times X$, and let π denote the projection $Y \rightarrow X$. If all fibres of π are finite sets, then π is a finite morphism.*

$$\begin{array}{ccc} Y & \xrightarrow{\subset} & \mathbb{P} \times X \\ \pi \downarrow & & \downarrow \\ X & \xlongequal{\quad} & X \end{array}$$

projchevfin

4.6.7. Corollary. *Let $\pi: Y \rightarrow X$ be a morphism of varieties whose fibres are finite sets, and suppose that Y is a projective variety. Then π is a finite morphism. In particular, if Y is a projective curve, any nonconstant morphism $Y \xrightarrow{u} X$ is a finite morphism.*

This corollary follows from the theorem when one replaces Y by the graph of π in $Y \times X$, which is isomorphic to Y . If Y is embedded as a closed subvariety of \mathbb{P} , the graph will be a closed subvariety of $\mathbb{P} \times X$ (Proposition 3.5.23). \square

In the next lemma, A denotes a finite-type domain, B denotes a quotient of the algebra $A[u]$ of polynomials in n variables u_1, \dots, u_n with coefficients in A , and $A \xrightarrow{\varphi} B$ denotes the canonical homomorphism. We'll use capital letters for nonhomogeneous polynomials here. If $G(u)$ is a polynomial in $A[u]$, we denote its image in B by $G(u)$ too.

powersofyenuf

4.6.8. Lemma. *Let k be a positive integer. Suppose that, for each $i = 1, \dots, n$, there is a polynomial $G_i(u_1, \dots, u_n)$ of degree at most $k-1$ in n variables, with coefficients in A , such that, in B , $u_i^k = G_i(u)$. Then B is a finite A -module.*

proof. Any monomial in u_1, \dots, u_n of degree $d \geq nk$ will be divisible by u_i^k for at least one i . So if m is a monomial of degree $d \geq nk$, the relations $u_i^k = G_i(u)$ show that, in B , m is equal to a polynomial in u_1, \dots, u_n of degree less than d , with coefficients in A . It follows by induction that the monomials in u_1, \dots, u_n of degree at most $nk-1$ span B . \square

Let y_0, \dots, y_n be coordinates in \mathbb{P}^n , and let $A[y_0, \dots, y_n]$ be the algebra of polynomials in y with coefficients in A . A *homogeneous element* of $A[y]$ is an element that is a homogeneous polynomial in y with coefficients in A . An ideal that can be generated by homogeneous polynomials is a *homogeneous ideal*.

hompolycoeffA

4.6.9. Lemma. *Let Y be a closed subset of $\mathbb{P} \times X$, where $X = \text{Spec } A$ is affine,*

- (i) *The ideal \mathcal{I} of elements of $A[y]$ that vanish at every point of Y is a homogeneous ideal of $A[y]$.*
- (ii) *If the zero locus of a homogeneous ideal \mathcal{I} of $A[y]$ is empty, then \mathcal{I} contains a power of the irrelevant ideal $\mathcal{M} = (y_0, \dots, y_n)$ of $A[y]$.*

proof. (i) Let's write a point of $\mathbb{P} \times X$ as $q = (y_0, \dots, y_n, x)$, using x to represent a point of X . So $(y, x) = (\lambda y, x)$. Then the proof for the case $A = \mathbb{C}$ that is given in (1.3.2) carries over.

(ii) Let V be the complement of the origin in the affine $n+1$ -space with coordinates y . Then $V \times X$ maps to $\mathbb{P} \times X$ (see 3.2.5). If the locus of zeros of \mathcal{I} in $\mathbb{P} \times X$ is empty, its locus of zeros in $V \times X$ will be contained in $o \times X$, o being the origin in \mathbb{P} . Then the radical of \mathcal{I} will contain the ideal of $o \times X$, which is the irrelevant ideal \mathcal{M} . \square

proof of Chevalley's Finiteness Theorem. This is Schelter's proof.

By induction on n , we may assume that the theorem is true when \mathbb{P} is a projective space of dimension $n-1$. We abbreviate the notation for a product of a variety Z with X , denoting $Z \times X$ by \tilde{Z} .

We are given a closed subvariety Y of $\tilde{\mathbb{P}} = \mathbb{P} \times X$, and the fibres over X are finite sets. We are to prove that the projection $Y \rightarrow X$ is a finite morphism (4.2.4). We may assume that X is affine, say $X = \text{Spec } A$.

Case 1. There is a hyperplane H in \mathbb{P} such that, in $\tilde{\mathbb{P}} = \mathbb{P} \times X$, Y is disjoint from $\tilde{H} = H \times X$.

This is the main case. We adjust coordinates y_0, \dots, y_n in \mathbb{P} so that H is the hyperplane at infinity $\{y_0 = 0\}$. Because Y is a closed subvariety of $\tilde{\mathbb{P}}$ disjoint from \tilde{H} , Y is also a closed subvariety of $\tilde{\mathbb{U}}^0 = \mathbb{U}^0 \times X$, \mathbb{U}^0 being the standard affine $\{y_0 \neq 0\}$. So Y is affine.

Let \mathcal{P} be the (homogeneous) prime ideal in $A[y]$ that defines Y , let \mathcal{Q} be the prime ideal that defines \tilde{H} , which is the principal ideal of $A[y]$ generated by y_0 , and let $\mathcal{I} = \mathcal{P} + \mathcal{Q}$. A homogeneous element of \mathcal{I} of degree k has the form $f(y) + y_0g(y)$, where f is a homogeneous polynomial of degree k , and g is a homogeneous polynomial of degree $k-1$.

The closed subsets Y and \tilde{H} are disjoint. Since $Y \cap \tilde{H}$ is empty, the sum $\mathcal{I} = \mathcal{P} + \mathcal{Q}$ contains a power of the irrelevant ideal $\mathcal{M} = (y_0, \dots, y_n)$. Say that $\mathcal{M}^k \subset \mathcal{I}$. Then y_i^k is in \mathcal{I} for $i = 0, \dots, n$. So we may write

$$(4.6.10) \quad y_i^k = f_i(y) + y_0g_i(y) \tag{fplusg}$$

with f_i in \mathcal{P} of degree k and g_i in $A[y]$ of degree $k-1$. For the index $i = 0$, we can set $f_0 = 0$ and $g_0 = x_0^{d-1}$. We can omit this trivial case.

We dehomogenize these equations with respect to the variables y , substituting $u_i = y_i/y_0$ for y_i , with $i = 0, \dots, n$, and $u_0 = 1$. Writing dehomogenizations with capital letters, the dehomogenized equations that correspond to the equations $y_i^k = f_i(y) + y_0g_i(y)$ have the form

$$(4.6.11) \quad u_i^k = F_i(u) + G_i(u) \tag{FplusG}$$

The important point is that the degree of G_i is at most $k-1$.

Recall that Y is also a closed subset of \mathbb{U}^0 . Its (nonhomogenous) ideal P in $A[u]$ contains the polynomials F_1, \dots, F_n , and its coordinate algebra is $B = A[u]/P$. In the quotient algebra B , the terms F_i of (4.6.11) drop out, leaving us with equations $u_i^k = G_i(u)$, which are true in B . Since G_i has degree at most $k-1$, Lemma 4.6.8 tells us that B is a finite A -algebra, as was to be shown.

This completes the proof of Case 1.

Case 2. the general case.

We have taken care of the case in which there exists a hyperplane H such that Y is disjoint from \tilde{H} . The next lemma shows that we can cover the given variety X by open subsets to which this special case applies. Then Lemma 4.6.4 and Proposition 4.6.4 will complete the proof.

4.6.12. Lemma. *Let Y be a closed subvariety of $\tilde{\mathbb{P}} = \mathbb{P}^n \times X$, and suppose that the projection $Y \xrightarrow{\pi} X$ has finite fibres. Suppose also that Chevalley's Theorem has been proved for closed subvarieties of $\mathbb{P}^{n-1} \times X$. For every point p of X , there is an open neighborhood X' of p in X , and there is a hyperplane H in \mathbb{P} , such that the inverse image $Y' = \pi^{-1}X'$ is disjoint from \tilde{H} .* avoid-plane

proof. Let p be a point of X , and let $\tilde{q} = (\tilde{q}_1, \dots, \tilde{q}_r)$ be the finite set of points of Y making up the fibre over p . We project \tilde{q} from $\mathbb{P} \times X$ to \mathbb{P} , obtaining a finite set $q = (q_1, \dots, q_r)$ of points of \mathbb{P} , and we choose a hyperplane H in \mathbb{P} that avoids this finite set. Then \tilde{H} avoids the fibre \tilde{q} . Let W denote the closed set $Y \cap \tilde{H}$. Because the fibres of Y over X are finite, so are the fibres of W over X . By hypothesis, Chevalley's Theorem is true for subvarieties of $\mathbb{P}^{n-1} \times X$, and \tilde{H} is isomorphic to $\mathbb{P}^{n-1} \times X$. It follows that, for every component W' of W , the morphism $W' \rightarrow X$ is a finite morphism, and therefore its image is closed in X (Theorem 4.4.2). Thus the image Z of W is a closed subset of X , and it doesn't contain p . Then $X' = X - Z$ is the required neighborhood of p . □

figure: ??I'm not sure

Section 4.7 Double Planes

(4.7.1) affine double planes

dplane
affdplanes

Let A be the polynomial algebra $\mathbb{C}[x, y]$, and let X be the affine plane $\text{Spec } A$. An *affine double plane* is a locus of the form $w^2 = f(x, y)$ in affine 3-space with coordinates w, x, y , where f is a square-free polynomial in x, y . (see Example 4.3.9). Let $B = \mathbb{C}[w, x, y]/(w^2 - f)$. So the affine double plane is $Y = \text{Spec } B$. The inclusion $A \subset B$ gives us an integral morphism $Y \rightarrow X$.

We'll denote by w, x, y both the variables and their residues in B . As in Example 4.3.9, B is a normal domain of dimension two, and a free A -module with basis $(1, w)$. It has an automorphism σ of order 2, defined by $\sigma(a + bw) = a - bw$.

The fibres of Y over X are the σ -orbits in Y . If $f(x_0, y_0) \neq 0$, the fibre consists of two points, and if $f(x_0, y_0) = 0$, it consists of one point. The reason that Y is called a *double plane* is that most points of the plane X are covered by two points of Y . The *branch locus* of the covering, which will be denoted by Δ , is the (possibly reducible) curve $\{f = 0\}$ in X . The fibres over the *branch points*, the points of Δ , are single points.

We study the closed subvarieties D of Y that lie over a curve C in X . These subvarieties of Y will have dimension one, and we call them curves too. If D lies over C , and if $D = D\sigma$, then D is the only curve lying over C . Otherwise, there will be two curves that lie over C , namely D and $D\sigma$. In that case we say that C *splits* in Y . (Recall that since we are writing the operation of σ on B on the left, it operates on the right on Y and therefore on the right on subsets of Y (2.8).)

A curve C in X will be the zero set of a principal prime ideal P of the polynomial algebra A , and if D lies over C , it will be the zero set of a prime ideal Q of B that lies over P (4.4.1). However, the prime ideal Q needn't be a principal ideal.

circleex-
ample

4.7.2. Example. Let $f(x, y) = x^2 + y^2 - 1$. The double plane $Y = \{w^2 = x^2 + y^2 - 1\}$ is an *affine quadric* in \mathbb{A}^3 . In the affine plane, its branch locus Δ is the curve $\{x^2 + y^2 = 1\}$.

The line $C_1 : \{y = 0\}$ in X meets the branch locus Δ transversally at the points $(x, y) = (\pm 1, 0)$, and when we set $y = 0$ in the equation for Y , we obtain the irreducible polynomial $w^2 - x^2 + 1$. So y generates a prime ideal of B . On the other hand, the line $C_2 : \{y = 1\}$ is tangent to Δ at the point $(0, 1)$, and it splits. When we set $y = 1$ in the equation for Y , we obtain $w^2 = x^2$. The locus $\{w^2 = x^2\}$ is the union of the two lines $\{w = x\}$ and $\{w = -x\}$ that lie over C_1 . The prime ideals of B that correspond to these lines aren't principal ideals.

circlelines

4.7.3.

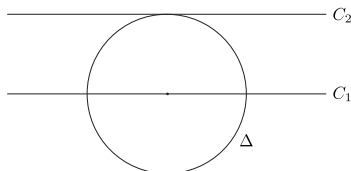

□

This example illustrates a general principle: If a curve intersects the branch locus transversally, it doesn't split. We explain this now.

localanal

(4.7.4) local analysis

Suppose that a plane curve $C : \{g = 0\}$ and the branch locus $\Delta : \{f = 0\}$ of a double plane $w^2 = f$ meet at a point p . We adjust coordinates so that p becomes the origin $(0, 0)$, and we write

$$f(x, y) = \sum a_{ij} x^i y^j = a_{10}x + a_{01}y + a_{20}x^2 + \dots$$

Since p is a point of Δ , the constant coefficient of f is zero. If the two linear coefficients aren't both zero, p will be a smooth point of Δ , and the tangent line to Δ at p will be the line $\{a_{10}x + a_{01}y = 0\}$. Similarly, writing $g(x, y) = \sum b_{ij} x^i y^j$, the tangent line to C , if defined, is the line $\{b_{10}x + b_{01}y = 0\}$.

Let's suppose that the two tangent lines are defined and distinct, i.e., that Δ and C intersect transversally at p . We change coordinates once more, to make the tangent lines the coordinate axes. After adjusting by scalar factors, the polynomials f and g will have the form

$$f(x, y) = x + u(x, y) \quad \text{and} \quad g(x, y) = y + v(x, y),$$

where u and v are polynomials all of whose terms have degree at least 2.

Let $X_1 = \text{Spec } \mathbb{C}[x_1, y_1]$ be another affine plane. We consider the map $X_1 \rightarrow X$ defined by the substitution $x_1 = x + u(x, y)$, $y_1 = y + v(x, y)$. In the classical topology, this map is invertible analytically (near the origin), because the Jacobian matrix

$$(4.7.5) \quad \left(\frac{\partial(x_1, y_1)}{\partial(x, y)} \right)_{(0,0)}$$

Jacob

at the origin p is the identity matrix. When we make this substitution, Δ becomes the locus $\{x_1 = 0\}$ and C becomes the locus $\{y_1 = 0\}$. In this local analytic coordinate system, the equation $w^2 = f$ that defines the double plane becomes $w^2 = x_1$. When we restrict it to C by setting $y_1 = 0$, x_1 becomes a local coordinate function on C . The restriction of the equation remains $w^2 = x_1$. So the inverse image Z of C can't be split analytically. Therefore it doesn't split algebraically either.

4.7.6. Corollary. *A curve that meets the branch locus transversally at some point doesn't split.* □

splitnot-transversal

This isn't a complete analysis. When C and Δ are tangent at every point of intersection, C may split or not, and which possibility occurs cannot be decided locally in most cases. However, one case in which a local analysis suffices to decide splitting is that C is a line. Let t be a coordinate in a line C , so that $C \approx \text{Spec } \mathbb{C}[t]$. Let's assume that C doesn't intersect Δ at $t = \infty$. The restriction of the polynomial f to C will give us a polynomial $\bar{f}(t)$ in t . A root of \bar{f} corresponds to an intersection of C with Δ , and a multiple root corresponds to an intersection at which C and Δ are tangent, or at which Δ is singular. The line C will split if and only if the polynomial $w^2 - f$ factors, i.e., if and only if \bar{f} is a square in $\mathbb{C}[t]$. This will be true if and only if every root of \bar{f} has even multiplicity. This happens when the intersection multiplicity of C and Δ at every intersection point is even.

A *rational curve* is a curve whose function field is a rational function field $\mathbb{C}(t)$ in one variable. One can make a similar analysis for any rational plane curve, a conic for example, but one needs to inspect its points at infinity and its singular points as well as its smooth points at finite distance.

(4.7.7) projective double planes

projdplane

Let X be the projective plane \mathbb{P}^2 , with coordinates x_0, x_1, x_2 . A *projective double plane* is a locus of the form

$$(4.7.8) \quad y^2 = f(x_0, x_1, x_2)$$

wtdplane

where f is a square-free, homogeneous polynomial of *even degree* $2d$. To regard this as a homogeneous equation, we must assign weight d to the variable y (see 1.7.7). Then, since we have weighted variables, we must work in a *weighted projective space* \mathbb{WP} with coordinates x_0, x_1, x_2, y , where x_i have weight 1 and y has weight d . A point of this weighted space \mathbb{WP} is represented by a nonzero vector (x_0, x_1, x_2, y) with the equivalence relation that, for all $\lambda \neq 0$, $(x_0, x_1, x_2, y) \sim (\lambda x_0, \lambda x_1, \lambda x_2, \lambda^d y)$. The points of the projective double plane Y are the points of \mathbb{WP} that solve the equation (4.7.8).

The projection $\mathbb{WP} \rightarrow X$ that sends (x, y) to x is defined at all points except at $(0, 0, 0, 1)$. If (x, y) solves (4.7.8) and if $x = 0$, then $y = 0$ too. So $(0, 0, 0, 1)$ can't be a point of Y . The projection is defined at all points of Y . The fibre of the morphism $Y \rightarrow X$ over a point x consists of points (x, y) and $(x, -y)$, which will be equal if and only if x lies on the *branch locus* of the double plane, the (possibly reducible) plane curve $\Delta : \{f = 0\}$ in X . The map $\sigma : (x, y) \rightsquigarrow (x, -y)$ is an automorphism of Y , and points of X correspond bijectively to σ -orbits in Y .

Since the double plane Y is embedded into a weighted projective space, it isn't presented to us as a projective variety in the usual sense. However, it can be embedded into a projective space in the following way: The projective plane X can be embedded by a Veronese embedding of higher order, using as coordinates the monomials $m = (m_1, m_2, \dots)$ of degree d in the variables x . This embeds X into a projective space \mathbb{P}^N where $N = \binom{d+2}{2} - 1$. When we add a coordinate y of weight d , we obtain an embedding of the weighted projective space \mathbb{WP} into \mathbb{P}^{N+1} that sends the point (x, y) to (m, y) . The double plane can be realized as a projective variety by this embedding.

When $Y \rightarrow X$ is a projective double plane, then, as happens with affine double planes, a curve C in X may split in Y or not. If C has a transversal intersection with the branch locus Δ , it will not split. On the other

hand, if C is a line, and if C intersects the branch locus Δ with multiplicity 2 at every intersection point, it will split.

bitansplit

4.7.9. Corollary. *Let Y be a double plane whose branch locus Δ is a generic quartic curve. The lines that split in Y are bitangent lines to Δ .* \square

(See Section 1.11.)

homogdplane

(4.7.10) homogenizing an affine double plane

To construct a projective double plane from an affine double plane, we write the affine double plane as

$$(4.7.11) \quad w^2 = F(u_1, u_2)$$

rela-
belaffd-
plane

for some nonhomogeneous polynomial F . We suppose that F has even degree $2d$, and we homogenize F , setting $u_i = x_i/x_0$. We multiply both sides of this equation by x_0^{2d} and set $y = x_0^d w$. This produces an equation of the form (4.7.8), where f is the homogenization of F .

If F has odd degree $2d - 1$, one needs to multiply F by x_0 in order to make the substitution $y = x_0^d w$ permissible. When we do this, the line at infinity $\{x_0 = 0\}$ becomes a part of the branch locus.

cubicisd-
plane

(4.7.12) cubic surfaces and quartic double planes

We use coordinates x_0, x_1, x_2, z for an (unweighted) projective 3-space \mathbb{P}^3 here, and X will denote the projective plane \mathbb{P}^2 with coordinates x_0, x_1, x_2 . Let $\mathbb{P}^3 \xrightarrow{\pi} X$ denote the projection that sends (x, z) to x . It is defined at all points except at the center of projection $q = (0, 0, 0, 1)$, and its fibres are the lines through q , with q omitted.

Let S be a cubic surface in \mathbb{P}^3 , the locus of zeros of an irreducible homogeneous cubic polynomial $g(x, z)$. We'll denote the restriction of π to S by the same symbol π .

Let's suppose that q is a point of S . Then the coefficient of z^3 in g will be zero. Therefore g will be quadratic in z : $g(x, z) = az^2 + bz + c$, where the coefficients a, b, c are homogeneous polynomials in x , of degrees 1, 2, 3, respectively. The equation for S becomes

projequa-
tion

$$(4.7.13) \quad az^2 + bz + c = 0$$

The discriminant $f = b^2 - 4ac$ of g is a homogeneous polynomial of degree 4 in x .

Let Y be the projective double plane

quarticd-
plane

$$(4.7.14) \quad y^2 = b^2 - 4ac$$

We denote by V the affine space whose coordinates are the coefficients of the polynomials a, b, c of degrees 1, 2, 3 in x , and by W the affine space whose coordinates are the coefficients of homogeneous quartic polynomials in x . Sending a polynomial g (4.7.13) to its discriminant f defines a morphism $V \xrightarrow{u} W$ (4.7.13).

quarticis-
generic

4.7.15. Lemma. *The image of the morphism u contains all quartic polynomials f such that the divisor $D : f = 0$ has at least one bitangent line. Therefore the image of u is dense in W .*

proof. Given such a quartic polynomial f , let a be a linear polynomial such that the line $\ell_1 : \{a = 0\}$ is a bitangent to $D : \{f = 0\}$. Then ℓ_1 splits in the double plane $y^2 = f$. So f is congruent to a square, modulo a . Let b be a quadratic polynomial such that $f \equiv b^2$, modulo a . When we take such a polynomial as b , we will have $f = b^2 - 4ac$ for some cubic polynomial c .

Conversely, if $g(x, z) = az^2 + bz + c$, the line $\ell_1 : \{a = 0\}$ will be a bitangent to D provided that the locus $b = 0$ meets ℓ_1 in two distinct points, which will be true when g is generic. \square

It follows from Lemma 4.7.15, which tells us that, when $g(x, z) = az^2 + bz + c$ is a polynomial in which a, b, c are generic homogeneous polynomials in x , of degrees 1, 2, 3, respectively, the discriminant $b^2 - 4ac$ will be a generic homogeneous quartic polynomial in x .

We suppose given a generic cubic surface $S : az^2 + bz + c = 0$. Let Y be the generic double plane $y^2 = b^2 - 4ac$.

4.7.16. Theorem. *A generic cubic surface S in \mathbb{P}^3 contains precisely 27 lines.*

twenty-seven

This theorem follows from next lemma, which relates the 27 lines in S to the 28 bitangents of the generic quartic curve $\Delta : \{b^2 - 4ac = 0\}$ (1.11.2).

4.7.17. Lemma. *Let S be a generic cubic surface $az^2 + bz + c = 0$, projected to the projective plane X from a generic point q of S , let $\Delta : \{b^2 - 4ac = 0\}$ be the discriminant curve, and let Y be the double plane $y^2 = b^2 - 4ac$.*

linesplits

(i) *The image ℓ in X of a line L in S is a line ℓ in X , and that line is a bitangent to the quartic curve Δ . Distinct lines in S have distinct images in X .*

(ii) *The line $\ell_1 : \{a = 0\}$ is a bitangent to Δ , but it isn't the image of a line in S .*

(iii) *Every bitangent ℓ to Δ that is distinct from ℓ_1 is the image of a line in S .*

proof. (i) The projection $\mathbb{P}^3 \rightarrow X$ maps a line L bijectively to a line ℓ unless L contains the center of projection q , in which case its image will be a point. Because our cubic surface S is generic, it contains finitely many lines (3.7). The generic point q of S won't lie on any of those lines. So the image of a line L in S will be a line ℓ in X .

A line ℓ in X is defined by a homogeneous linear equation in the variables x . The same linear equation defines a plane H in \mathbb{P}^3 that contains q , and the intersection $C = S \cap H$ will be a cubic curve in H . This curve is essentially the inverse image of ℓ via the projection $S \rightarrow X$, though the projection is undefined at q . Let's call it the inverse image anyway.

At least one of the irreducible components of C contains q , and because S doesn't contain lines through q , that component isn't a line. So if C is reducible, the component containing q will be a conic Q , and C will be a union $Q \cup L$ and L is a line in S . Thus lines L in S correspond bijectively to lines in X such that the corresponding cubic C is reducible.

(ii) The inverse image C in S of the line ℓ_1 is the locus $a = 0$ and $az^2 + bz + c = 0$, or equivalently, $a = 0$ and $bz + c = 0$.

Let's adjust coordinates so that a becomes the polynomial x_0 . The locus $\{x_0 = 0\}$ in \mathbb{P}^3 is the projective plane P with coordinates x_1, x_2, z , and in P , C is the locus $\bar{g} = 0$, where $\bar{g} = \bar{b}z + \bar{c}$, \bar{b} and \bar{c} being the polynomials obtained from b and c by substituting $x_0 = 0$. In P , the point q becomes $(0, 0, 1)$, and C becomes the cubic curve $\bar{g} = 0$. This cubic curve is singular at q because \bar{g} has no term of degree > 1 in z . As we have noted, C doesn't contain a line through q . Since its degree is three, C must be an irreducible cubic curve. So ℓ_1 doesn't split.

(iii) Referring to (4.7.13) and (4.7.14), the quadratic formula solves for z in terms of a and y , whenever $a \neq 0$:

$$(4.7.18) \quad z = \frac{-b + y}{2a} \quad \text{or} \quad y = 2az + b$$

quadrformula

These equations define a bijection $S' \longleftrightarrow Y'$ between the open subsets S' and Y' of points of S and Y at which $a \neq 0$. A point of Y at which $a \neq 0$ is one that isn't on the line ℓ_1 .

If a line ℓ in X is distinct from the line ℓ_1 , the intersection $\ell \cap \ell_1$ will be a single point p . The bijection $S' \longleftrightarrow Y'$ will be defined at all points that lie over ℓ except at the finite set of points over p . If ℓ is a bitangent line, it splits in Y , and therefore it splits in S too. The cubic curve $C = S \cap H$ will be reducible. It will be the union of a line L and a conic. So every bitangent line distinct from ℓ_1 is the image of a unique line in S . \square

Summing up: The 27 bitangents distinct from the bitangent $\ell_1 : \{a = 0\}$ are images of lines in S , but ℓ_1 is not the image of a line in S .

Section 4.8 Exercises

chap-
fourexerc

counting constants

xdcc

4.8.1. A ring A is said to have the *descending chain condition* (dcc) if every strictly decreasing chain of ideals $I_1 > I_2 > \cdots$ is finite. Let A be a finite type \mathbb{C} -algebra. Prove

(a) A has dcc if and only if it is a finite dimensional complex vector space.

(b) If A has dcc, then it has finitely many maximal ideals, and every prime ideal is maximal.

(c) If a finite-type algebra A has finitely many maximal ideals, then A has dcc.

(d) (*strong Nakayama*) Suppose that A has dcc, let M be an arbitrary A -module, and let I denote the intersection of the maximal ideals of A . If $IM = M$, then $M = 0$. (The usual Nakayama lemma requires that M be finitely generated.)

4.8.2. A module M over a ring B is *faithful* if, for every nonzero element b of B , scalar multiplication by b isn't the zero operation on M . Let A be a domain, let z be an element of its field of fractions, and let B be the ring generated by z over A . Suppose there is a faithful B -module M that is finitely generated as an A -module. Prove that z is integral over A .

xfinmod-
fld

4.8.3. Let $A \subset B$ be noetherian domains and suppose that B is a finite A -module. Prove that A is a field if and only if B is a field.

xaltnull

4.8.4. Use Noether Normalization to prove this alternate form of the Nullstellensatz: Let k be a field, and let B be a domain that is a finitely generated k -algebra. If B is a field, then $[B : k] < \infty$.

xinversint

4.8.5. Let A be a domain with fraction field K , and let α and β be elements of K such that $\alpha\beta = 1$. Prove that if α is integral over $A[\beta]$, then it is an element of $A[\beta]$, and it is integral over A .

4.8.6. Let X and Y be varieties with the same functions field K . Show that there are open subsets Y' and X' of Y and X , respectively, that are isomorphic.

chainmax-
imalx
xpchain-
max
dimdim

4.8.7. Verify directly that the prime chain **4.5.8** is maximal.

4.8.8. Prove that $\mathbb{P}^n > \mathbb{P}^{n-1} > \cdots > \mathbb{P}^0$ is a maximal chain of closed subsets of \mathbb{P}^n .

4.8.9. Let $Y \xrightarrow{u} X$ be a surjective morphism, and let K and L be the function fields of X and Y , respectively. Show that if $\dim Y = \dim X$, there is a nonempty open subset X' of X such that all fibres over points of X' have the same order n , and that $n = [L : K]$.

4.8.10. Let $Y \rightarrow X$ be an affine double plane, and let D be a curve in Y whose image in X is a plane curve C . Say that C has degree d . Define $\deg D$ to be d if C splits and $2d$ if C remains prime or ramifies. Most curves C in X will intersect the branch locus transversally. Therefore they won't wplit. On the other hand, most curves D in Y will not be symmetric with respect to the automorphism σ of Y over X . Then there will be two curves $D, D\sigma$ lying over C , so C will split. Try to explain this curious point, with reference to the degrees of C and D .

4.8.11. With reference to Example 4.4.6, determine generators for the prime ideal P of A such that $V_X(P) = C$.

4.8.12. $A \subset B$ be an extension of finite-type algebras such that B is a finite A -module, and let P be a prime ideal of A . Prove that the number of prime ideals of B that lie over P is at most equal to the degree $[L : K]$ of the field extension.

4.8.13. Work out the proof of Chevalley's Theorem in the case that Y is a closed subset of $\tilde{X} = X \times \mathbb{P}^1$ that doesn't meet the locus at infinity \tilde{H} . (In \mathbb{P}^1 , H will be the point at infinity, and $\tilde{H} = X \times H$.) Do this in the following way: Say that $X = \text{Spec } A$. Let $B_0 = A[u]$, $B_1 = A[v]$, and $B_{01} = A[u, v]$, where $u = y_1/y_0$ and $v = u^{-1} = y_0/y_1$. Then $X \times U^0 = \tilde{U}^0 = \text{Spec } B_0$, $\tilde{U}^1 = \text{Spec } B_1$, and $tU^{01} = \text{Spec } B_{01}$. Let P_1 be the ideal of B_1 that defines $Y \cap \tilde{U}^1$, and let P_0 be the analogous ideal of B_0 . In B_1 , the ideal of \tilde{H} is the principal ideal vB_1 . Since $Y \cap \tilde{H} = \emptyset$, $P_1 + vB_1$ is the unit ideal of B_1 . Write out what this means. Then go over to the open set \tilde{U}^0 , and show that the residue of u in the coordinate algebra B_0/P_0 of Y is the root of a monic polynomial.

4.8.14. With reference to Example 4.7.2, show that the prime ideal that corresponds to the line $w = x$ is not a principal ideal.

4.8.15. Prove that a nonconstant morphism from a curve Y to \mathbb{P}^1 is a finite morphism without appealing to Chevalley's Theorem.

4.8.16. Let $Y = \text{Spec } B$ be an affine variety, let D_1, \dots, D_n be distinct closed subvarieties of Y and let V be a closed subset of Y . Assume that V doesn't contain any of the sets D_j . There is an element β of B that vanishes on V , but isn't identically zero on any D_j .

4.8.17. Prove every nonconstant morphism $\mathbb{P}^2 \rightarrow \mathbb{P}^2$ is a finite morphism.

4.8.18. Let $A \subset B$ be finite type domains with fraction fields $K \subset L$, and let $Y \rightarrow X$ be the corresponding morphism of affine varieties. Prove the following:

- (a) There is a nonzero element $s \in A$ such that A_s is integrally closed.
- (b) There is a nonzero element $s \in A$ such that B_s is a finite module over a polynomial ring $A_s[y_1, \dots, y_d]$.
- (c) Suppose that L is a finite extension of K of degree d . There is a nonzero element $s \in A$ such that all fibres of the morphism $Y \rightarrow X$ consist of d points.

4.8.19. A module M over a ring B is *faithful* if, for every nonzero element b of B , scalar multiplication by b isn't the zero operation on M . Let A be a domain, let z be an element of its field of fractions, and let B be the ring generated by z over A . Suppose there is a faithful B -module M that is finitely generated as an A -module. Prove that z is integral over A .

4.8.20. Let A be a finite type domain, $R = \mathbb{C}[t]$, $X = \text{Spec } A$, and $Y = \text{Spec } R$. Let $\varphi : A \rightarrow R$ be a homomorphism whose image is not \mathbb{C} , and let $\pi : Y \rightarrow X$ be the corresponding morphism.

- (a) Show that R is a finite A -module.
- (b) Show that the image of π is a closed subset of X .

4.8.21. Let G be a finite group of automorphisms of a normal, finite-type domain B , let A be the algebra of invariant elements of B , and let $Y \xrightarrow{u} X$ be the integral morphism of varieties corresponding to the inclusion $A \subset B$. Prove that there is a bijective correspondence between G -orbits of closed subvarieties of Y and closed subvarieties of X .

4.8.22. Let Y be a closed subvariety of projective space \mathbb{P}^n with coordinates y_0, \dots, y_n , let d be a positive integer, and let w_0, \dots, w_k be homogeneous polynomials in y of degree d that have no common zeros on Y . Prove that sending a point q of Y to $(w_0(q), \dots, w_k(q))$ defines a finite morphism $Y \xrightarrow{u} \mathbb{P}^k$. Consider the case that $w = u_1, \dots, u_k$ first.

4.8.23. Let $Y \xrightarrow{u} X$ be a finite morphism of curves, and let K and L be the function fields of X and Y , respectively, and suppose $[L : K] = n$. Prove that all fibres have order at most n , and all but finitely many fibres of Y over X have order equal to n .

xmapcurvefin

xPtwoPt-
wofinite
xAsint-
closed

xfait-
fulint

ximclosed

xorbits

xmapYtoP

countfib

Chapter 5 STRUCTURE OF VARIETIES IN THE ZARISKI TOPOLOGY

- 5.1 Modules – a review
- 5.2 Valuations
- 5.3 Smooth Curves
- 5.4 Constructible sets
- 5.5 Closed Sets
- 5.6 Fibred Products
- 5.7 Projective Varieties are Proper
- 5.8 Fibre Dimension

The main goal of this chapter is to show how algebraic curves control the geometry of higher dimensional varieties. We do this, beginning in Section 5.5.

Section 5.1 Modules – a review

moduleloc We start with a brief review of modules, omitting proofs.

exactseq **(5.1.1) exact sequences**

Let R be a ring. A sequence

$$\dots \rightarrow V^{n-1} \xrightarrow{d^{n-1}} V^n \xrightarrow{d^n} V^{n+1} \xrightarrow{d^{n+1}} \dots$$

of homomorphisms of R -modules is *exact* if the image of d^{k-1} is equal to the kernel of d^k . For example, a sequence $0 \rightarrow V \xrightarrow{d} V'$ is exact if the map d is injective, and a sequence $V \xrightarrow{d} V' \rightarrow 0$ is exact, if d is surjective. Any homomorphism $V \xrightarrow{d} V'$ can be embedded into an exact sequence

$$0 \rightarrow K \rightarrow V \xrightarrow{d} V' \rightarrow C \rightarrow 0,$$

where K and C are the kernel and cokernel of d , respectively.

A *short exact sequence* is an exact sequence of the form

$$0 \rightarrow V \xrightarrow{a} V' \xrightarrow{b} V'' \rightarrow 0.$$

To say that this sequence is exact means that the map a is injective, and that V'' is isomorphic to the quotient module V'/aV .

snake **5.1.2. Proposition.** (*functorial property of the kernel and cokernel*) Suppose given a (commutative) diagram of R -modules

$$\begin{array}{ccccccc} V & \xrightarrow{u} & V' & \longrightarrow & V'' & \longrightarrow & 0 \\ f \downarrow & & f' \downarrow & & f'' \downarrow & & \\ 0 & \longrightarrow & W & \longrightarrow & W' & \xrightarrow{v} & W'' \end{array}$$

whose rows are exact sequences. Let K, K', K'' and C, C', C'' denote the kernels and cokernels of $f, f',$ and f'' , respectively.

(i) **(kernel is left exact)** The kernels form an exact sequence $K \rightarrow K' \rightarrow K''$. If u is injective, the sequence $0 \rightarrow K \rightarrow K' \rightarrow K''$ is exact.

(ii) **(cokernel is right exact)** The cokernels form an exact sequence $C \rightarrow C' \rightarrow C''$. If v is surjective, the sequence $C \rightarrow C' \rightarrow C'' \rightarrow 0$ is exact.

(iii) **(Snake Lemma)** There is a canonical homomorphism $K'' \xrightarrow{d} C$ that combines with the above sequences to form an exact sequence

$$K \rightarrow K' \rightarrow K'' \xrightarrow{d} C \rightarrow C' \rightarrow C''.$$

If u is injective and/or v is surjective, the sequence remains exact with zeros at the appropriate ends. □

(5.1.3) tensor products

tensprod

Let U and V be modules over a ring R . The *tensor product* $U \otimes_R V$ is an R -module that is generated by elements $u \otimes v$ called *tensors*, one for each u in U and v in V . Its elements are combinations of tensors with coefficients in R .

The defining relations among the tensors are the *bilinear relations*:

$$(5.1.4) \quad (u_1 + u_2) \otimes v = u_1 \otimes v + u_2 \otimes v, \quad u \otimes (v_1 + v_2) = u \otimes v_1 + u \otimes v_2$$

bilinrels

and

$$r(u \otimes v) = (ru) \otimes v = u \otimes (rv)$$

for all u in U , v in V , and r in R . The symbol \otimes is used as a reminder that the tensors are to be manipulated using these relations.

One can absorb a coefficient from R into either one of the factors of a tensor, so every element of $U \otimes_R V$ can be written as a finite sum $\sum u_i \otimes v_i$ with u_i in U and v_i in V .

5.1.5. Example. If U and V are free R -modules with bases $\{u_i\}$ and $\{v_j\}$, respectively, then $U \otimes_R V$ is a free R -module with basis $\{u_i \otimes v_j\}$. If U is the space of m dimensional (complex) column vectors, and V is the space of n -dimensional row vectors. Then $U \otimes_{\mathbb{C}} V$ identifies naturally with the space of $m \times n$ -matrices.

colxrow

The product *module* $U \times V$ and the tensor product module $U \otimes_R V$ are very different. For instance, when U and V are free modules of ranks r and s , $U \times V$ is free of rank $r+s$, while $U \otimes_R V$ is free of rank rs . (The *rank* of a free module M is the number of elements in a basis – the integer r such that $M \approx R^r$.)

There is an obvious map of sets

$$(5.1.6) \quad U \times V \xrightarrow{\beta} U \otimes_R V$$

bilin

from the product *set* to the tensor product, that sends a pair (u, v) to the tensor $u \otimes v$. This map isn't a homomorphism. The defining relations (5.1.4) show that it is *R-bilinear*, not *R-linear*. It is a universal bilinear map.

5.1.7. Corollary. Let $U, V,$ and W be R -modules. Homomorphisms of R -modules $U \otimes_R V \rightarrow W$ correspond bijectively to R -bilinear maps $U \times V \rightarrow W$.

tensorbilin

This follows from the defining relations. □

Thus, any R -bilinear map $U \times V \xrightarrow{f} W$ to a module W can be obtained from a module homomorphism $U \otimes_R V \xrightarrow{\tilde{f}} W$ by composition with the bilinear map β defined above: $U \times V \xrightarrow{\beta} U \otimes_R V \xrightarrow{\tilde{f}} W$.

5.1.8. Proposition. There are canonical isomorphisms

canonisom

- $U \otimes_R R \approx U$, defined by $u \otimes r \rightsquigarrow ur$
- $(U \oplus U') \otimes_R V \approx (U \otimes_R V) \oplus (U' \otimes_R V)$, defined by $(u_1 + u_2) \otimes v \rightsquigarrow u_1 \otimes v + u_2 \otimes v$
- $U \otimes_R V \approx V \otimes_R U$, defined by $u \otimes v \rightsquigarrow v \otimes u$
- $(U \otimes_R V) \otimes_R W \approx U \otimes_R (V \otimes_R W)$, defined by $(u \otimes v) \otimes w \rightsquigarrow u \otimes (v \otimes w)$ □

rextens-
sor

5.1.9. Proposition. Tensor product is right exact Let $U \xrightarrow{f} U' \xrightarrow{g} U'' \rightarrow 0$ be an exact sequence of R -modules. For any R -module V , the sequence

$$U \otimes_R V \xrightarrow{f \otimes 1} U' \otimes_R V \xrightarrow{g \otimes 1} U'' \otimes_R V \rightarrow 0$$

is exact. □

Tensor product isn't left exact. For example, if $R = \mathbb{C}[x]$, then $R/xR \approx \mathbb{C}$, so there is an exact sequence $0 \rightarrow R \xrightarrow{x} R \rightarrow \mathbb{C} \rightarrow 0$. When we tensor with \mathbb{C} we get a sequence $0 \rightarrow \mathbb{C} \rightarrow \mathbb{C} \rightarrow \mathbb{C} \rightarrow 0$, in which the first map $\mathbb{C} \rightarrow \mathbb{C}$ is the zero map. The sequence isn't exact on the left.

proof of Proposition 5.1.9. We are given an exact sequence of R -modules $U \xrightarrow{f} U' \xrightarrow{g} U'' \rightarrow 0$ and another R -module V . We are to prove that the sequence $U \otimes_R V \xrightarrow{f \otimes 1} U' \otimes_R V \xrightarrow{g \otimes 1} U'' \otimes_R V \rightarrow 0$ is exact. It is evident that the composition $(g \otimes 1)(f \otimes 1)$ is zero, and that $g \otimes 1$ is surjective. We must prove that $U'' \otimes_R V$ is isomorphic to the cokernel of $f \otimes 1$. Let C denote that cokernel. There is a canonical map $C \xrightarrow{\varphi} U'' \otimes_R V$ that we want to show is an isomorphism. To do this, we construct its inverse. We choose an element v of V , and form a diagram

$$\begin{array}{ccccccc} U \times v & \longrightarrow & U' \times v & \longrightarrow & U'' \times v & \longrightarrow & 0 \\ \beta_v \downarrow & & \beta'_v \downarrow & & \downarrow \gamma_v & & \\ U \otimes_R V & \xrightarrow{f \otimes 1} & U' \otimes_R V & \longrightarrow & C & \longrightarrow & 0 \end{array}$$

The rows are exact sequences and the vertical arrows β_v and β'_v are restrictions of the canonical bilinear maps (5.1.6). Then γ_v is determined by the functorial property of the cokernel. Putting the maps γ_v for all v in V together gives us a bilinear map $U \times V \rightarrow C$, that induces a linear map $U \otimes_R V \rightarrow C$ (5.1.7). That map is the inverse of φ . □

locisten-
sor

5.1.10. Corollary. Let U and V be modules over a domain R and let s be a nonzero element of R . Let R_s, U_s, V_s be the localizations of R, U, V , respectively.

(i) There is a canonical isomorphism $U \otimes_R (R_s) \approx U_s$.

(ii) Tensor product is compatible with localization: $U_s \otimes_{R_s} V_s \approx (U \otimes_R V)_s$.

proof. (ii) The composition of the canonical maps $U \times V \rightarrow U_s \times V_s \rightarrow U_s \otimes_{R_s} V_s$ is an R -bilinear map. It defines an R -linear map $U \otimes_R V \rightarrow U_s \otimes_{R_s} V_s$. Since s is invertible in $U_s \otimes_{R_s} V_s$, this map extends to an R_s -linear map $(U \otimes_R V)_s \rightarrow U_s \otimes_{R_s} V_s$. To invert this map, we define an R_s -bilinear map $U_s \times V_s \rightarrow (U \otimes_R V)_s$ by mapping a pair (us^{-m}, vs^{-n}) to $(u \otimes v)s^{-m+n}$. This bilinear map induces the required map $U_s \otimes_{R_s} V_s \rightarrow (U \otimes_R V)_s$. □

extend-
scalars

(5.1.11) extension of scalars in a module

Let $A \xrightarrow{\rho} B$ be a ring homomorphism. Extension of scalars is an operation that constructs an B -module from an A -module.

Let's write scalar multiplication on the right. So M will be a right A -module. Then $M \otimes_A B$ becomes a right B -module, multiplication by $s \in B$ being $(m \otimes a)s = m \otimes (as)$. This gives the functor

$$A\text{-modules} \xrightarrow{\otimes B} B\text{-modules}$$

called the *extension of scalars* from A to B .

resscal

(5.1.12) restriction of scalars

If $A \xrightarrow{\rho} B$ is a ring homomorphism, a B -module N can be made into an A -module by *restriction of scalars*, scalar multiplication by an element a of A being defined by the formula

restrscal

$$(5.1.13) \quad an = \rho(a)n$$

It is customary to denote a module and the one obtained by restriction of scalars by the same symbol. But if it seems necessary in order to avoid confusion, we may denote a B -module N and the A -module obtained from it by restriction of scalars by ${}_B N$ and ${}_A N$, respectively.

5.1.14. Lemma. *extension and restriction of scalars are adjoint operators*

extscal-
tens

Let $A \xrightarrow{\rho} B$ be a ring homomorphism, let M be an A -module, and let M' be an B -module. Homomorphisms $M \xrightarrow{\varphi} {}_A N$ of A -modules correspond bijectively to homomorphisms of B -modules $M \otimes_A B \xrightarrow{\psi} N$. \square

(5.1.15) local rings

localrings

A *local ring* is a noetherian ring that contains just one maximal ideal. We make a few general comments about local rings here though we will be interested mainly in some special ones, the discrete valuation rings that are discussed below.

Let R be a local ring with maximal ideal M . The quotient $R/M = k$ is a field that is called the *residue field* of R . For us, the residue field k will usually be the field of complex numbers.

An element of R that isn't in M isn't in any maximal ideal, so it is a unit.

The Nakayama Lemma 4.1.3 has a useful version for local rings:

5.1.16. Local Nakayama Lemma. *Let R be a local ring with maximal ideal M and residue field k . Let V be a finite R -module, and let \bar{V} be the quotient V/MV , which can also be written as the tensor product $V \otimes_A k$. If $\bar{V} = 0$, then $V = 0$.*

local-
nakayama

proof. If $\bar{V} = 0$, then $V = MV$. The usual Nakayama Lemma tells us that M contains an element z such that $1 - z$ annihilates V . Then $1 - z$ isn't in M , so it is a unit. A unit annihilates V , and therefore $V = 0$. \square

Section 5.2 Valuations

A local domain R with maximal ideal M has *dimension one* if (0) and M are the only prime ideals of R , and if they are distinct. We describe the *normal* local domains of dimension one in this section. They are the discrete valuation rings that are defined below.

dvr

Let K be a field. A *discrete valuation* v on K is a surjective homomorphism

$$(5.2.1) \quad K^\times \xrightarrow{v} \mathbb{Z}^+$$

dval

from the multiplicative group of nonzero elements of K to the additive group of integers, such that, if a, b are elements of K and if a, b and $a+b$ aren't zero, then

- $v(a+b) \geq \min\{v(a), v(b)\}$.

The word "discrete" refers to the fact that \mathbb{Z}^+ has the discrete topology. Other valuations exist. They are interesting, but less important, and we won't use them. To simplify terminology, we refer to a discrete valuation simply as a *valuation*.

Let k be a positive integer. If v is a valuation and if $v(a) = k$, then k is called the *order of zero of a* , and if $v(a) = -k$, then k is called the *order of pole of a* , with respect to the valuation.

5.2.2. Lemma. *Let v be a valuation on a field K that contains the complex numbers. Every nonzero complex number has value zero.*

valczero

proof. This is true because \mathbb{C} contains n th roots. If γ is an n th root of a nonzero complex number c , then because v is a homomorphism $v(c) = n v(\gamma)$, so $v(c)$ is divisible by n . The only integer that is divisible by every positive integer is zero. \square

The *valuation ring* R associated to a valuation v on a field K is the subring of elements of K with non-negative values, together with zero:

valnring (5.2.3)
$$R = \{a \in K^\times \mid v(a) \geq 0\} \cup \{0\}.$$

Valuation rings are usually called “discrete valuation rings”, but we have dropped the adjective discrete from the valuation, so we drop it from the valuation ring too.

valsinCt **5.2.4. Proposition.** *Valuations of the field $\mathbb{C}(t)$ of rational functions in one variable correspond bijectively to points of the projective line \mathbb{P}_t^1 . The valuation ring that corresponds to a point $p \neq \infty$ is the local ring of the polynomial ring $\mathbb{C}[t]$ at p .*

beginning of the proof. Let K denote the field $\mathbb{C}(t)$, and let a be a complex number. To define the valuation v that corresponds to the point $p : t = a$ of \mathbb{P}^1 , we write a nonzero polynomial f as $(t - a)^k h$, where $t - a$ doesn't divide h , and we define, $v(f) = k$. Then we define $v(f/g) = v(f) - v(g)$. You will be able to check that with this definition, v becomes a valuation whose valuation ring is the algebra of regular functions at p (2.7.1). This algebra is called the *local ring at p* (see (5.2.8) below). The valuation that corresponds to the point at infinity of \mathbb{P}^1 is obtained by working with t^{-1} in place of t .

The proof that these are all of the valuations of $\mathbb{C}(t)$ will be given at the end of the section.

idealsin-valnring **5.2.5. Proposition.** *Let v be a valuation on a field K , let R be its valuation ring, and let x be a nonzero element of K with value $v(x) = 1$.*

(i) *The ring R is a normal local domain of dimension one. Its maximal ideal M is the principal ideal xR . The elements of M are the elements of K with positive value, together with zero:*

$$M = \{a \in K^\times \mid v(a) > 0\} \cup \{0\}$$

(ii) *The units of R are the elements of K^\times with value zero. Every nonzero element z of K has the form $z = x^k u$, where u is a unit and $k = v(z)$ can be any integer.*

(iii) *The proper R -submodules of K are the sets $x^k R$, where k is a positive or negative integer. The set $x^k R$ consists of zero and the elements of K^\times with value $\geq k$. The nonzero ideals of R are the principal ideals $x^k R$ with $k \geq 0$. They are the powers of the maximal ideal.*

(iv) *There is no ring properly between R and K : If R' is a ring and if $R \subset R' \subset K$, then either $R = R'$ or $R' = K$.*

proof. We prove (i) last.

(ii) Since v is a homomorphism, $v(u^{-1}) = -v(u)$. Then u is a unit of R , i.e., u and u^{-1} are both in R , if and only if $v(u) = 0$. If z is a nonzero element of K with $v(z) = k$, then $u = x^{-k} z$ has value zero, so it is a unit, and $z = x^k u$.

(iii) The R -module $x^k R$ consists of the elements of K of value at least k . Suppose that a nonzero R -submodule N of K contains an element z with value k . Then $z = x^k u$, where u is a unit, and therefore N contains x^k , and $x^k R \subset N$. If k is the smallest integer such that N contains an element z with value k , then $N = x^k R$. If there is no minimum value of the elements of N , then N contains $x^k R$ for every k , and $N = K$.

(iv) This follows from (iii). The ring R' will be a nonzero R -submodule of K . Since $R' \neq K$, $R' = x^k R$ for some k . If R' contains R , then $k \leq 0$. If $k < 0$ then $x^k R$ isn't closed under multiplication. So $k = 0$ and $R' = R$.

(i) First, R is noetherian because (iii) tells us that it is a principal ideal domain, and it follows from (ii) that the only prime ideals of R are $\{0\}$ and $M = xR$, where x is an element of R with value 1. So R is a local ring of dimension 1. If the normalization of R were larger than R , then according to (iv), it would be equal to K . Then x^{-1} would be integral over R . It would satisfy a polynomial relation $x^{-r} + a_1 x^{-(r-1)} + \dots + a_r = 0$ with a_i in R . When one multiplies this relation by x^r , one sees that 1 would be a multiple of x . Then x would be a unit, which it is not. \square

characterizedvr **5.2.6. Theorem.**

(i) *A local domain whose maximal ideal is a nonzero principal ideal is a valuation ring.*

(ii) *Every normal local domain of dimension 1 is a valuation ring.*

proof. (i) Let R be a local domain whose maximal ideal M is a nonzero principal ideal, say $M = xR$, with $x \neq 0$, and let y be a nonzero element of R . The integers k such that x^k divides y are bounded (4.1.6). Let x^k be the largest power that divides y . Then $y = ux^k$, where $k \geq 0$ and u is in R but not in M . It is a unit. Then any nonzero element z of the fraction field K of R will have the form $z = ux^r$ where u is a unit and r is an integer, possibly negative. This is shown by writing the numerator and denominator of a fraction in such a form and dividing.

The valuation whose valuation ring is R is defined by $v(z) = r$ when $z = ux^r$ as above. If $z_i = u_i x^{r_i}$ for $i = 1, 2$, where u_i are units and $r_1 \leq r_2$, then $z_1 + z_2 = \alpha x^{r_1}$, where $\alpha = u_1 + u_2 x^{r_2 - r_1}$ is an element of R . Therefore $v(z_1 + z_2) \geq r_1 = \min\{v(z_1), v(z_2)\}$. We also have $v(z_1 z_2) = v(z_1) + v(z_2)$. Thus v is a surjective homomorphism. The requirements for a valuation are satisfied.

(ii) The fact that a valuation ring is a normal, one-dimensional local ring is Proposition 5.2.5 (i). We show that a normal local domain R of dimension 1 is a valuation ring by showing that its maximal ideal is a principal ideal. The proof is tricky.

Let z be a nonzero element of M . Because R is a local ring of dimension 1, M is the only prime ideal that contains z , so M is the radical of the principal ideal zR , and $M^r \subset zR$ if r is large. Let r be the smallest integer such that $M^r \subset zR$. Then there is an element y in M^{r-1} that isn't in zR , but such that $yM \subset zR$. We restate this by saying that $w = y/z \notin R$, but $wM \subset R$. Since M is an ideal, multiplication by an element of R carries wM to wM . So wM is an ideal of R . Since M is the maximal ideal of the local ring R , either $wM \subset M$, or $wM = R$. If $wM \subset M$, the lemma below shows that w is integral over R . This can't happen because R is normal and w isn't in R . Therefore $wM = R$ and $M = w^{-1}R$. This implies that w^{-1} is in R and that M is a principal ideal. \square

5.2.7. Lemma. *Let I be a nonzero ideal of a noetherian domain A , and let B be a domain that contains A . An element w of B such that $wI \subset I$ is integral over A .*

betainte-graltwo

proof. This is the Nakayama Lemma once more. Because A is noetherian, I is finitely generated. Let $v = (v_1, \dots, v_n)^t$ be a vector whose entries generate I . The hypothesis $wI \subset I$ allows us to write $wv_i = \sum p_{ij}v_j$ with p_{ij} in A , or in matrix notation, $wv = Pv$. So w is an eigenvalue of P . If $p(t)$ denotes the characteristic polynomial of P , $p(w)v = 0$. Since $I \neq 0$, at least one v_i is nonzero. Since A is a domain, $p(w)v_i = 0$ implies that $p(w) = 0$. The characteristic polynomial is a monic polynomial with coefficients in A , so w is integral over A . \square

(5.2.8) the local ring at a point

local-ringatp

Let \mathfrak{m} be the maximal ideal at a point p of an affine variety $X = \text{Spec } A$, and let S be the complement of \mathfrak{m} in A . This is a multiplicative system, and the prime ideals P of the localization AS^{-1} are extensions of the prime ideals Q of A that are contained in \mathfrak{m} : $P = QS^{-1}$ (2.6.8). Thus AS^{-1} is a local ring whose maximal ideal is $\mathfrak{m}S^{-1}$. This ring is called the *local ring of A at p* , and is often denoted by A_p .

Any finite set $\alpha_1, \dots, \alpha_k$ of elements of the local ring A_p at p will be contained in a simple localization A_s , for some s in S .

For example, let $X = \text{Spec } A$ be the affine line, $A = \mathbb{C}[t]$, and let p be the point $t = 0$. The local ring A_p is the ring whose elements are fractions $f(t)/g(t)$ with $g(0) \neq 0$.

The local ring of a variety, not necessarily affine, at a point p is the the local ring at p of an affine open neighborhood of p .

5.2.9. Lemma. *A rational function α on a variety X is regular on X if it is in the local ring of X at every point p of X .*

ineverylocalring

5.2.10. Corollary. *Let $X = \text{Spec } A$ be an affine variety.*

intloc

(i) *The coordinate algebra A is the intersection of the local rings A_p at the points of X .*

$$A = \bigcap_{p \in X} A_p$$

intersect-codimoneagain

(ii) *The coordinate algebra A is normal if and only if all of its local rings A_p are normal.*

See Lemma 4.3.4 for (ii). □

5.2.11. Note. (about the overused word local) A property is true *locally* on a topological space X if every point p of X has an open neighborhood U such that the property is true on U .

In these notes, the words *localize* and *localization* usually refer to the process of adjoining inverses. The localizations X_s of an affine variety $X = \text{Spec } A$ form a basis for the topology on X . So if some property is true locally on X , one can cover X by localizations on which the property is true. There will be elements s_1, \dots, s_k of A that generate the unit ideal, such that the property is true on each of the localizations X_{s_i} .

An A -module M is *locally free* if there are elements s_1, \dots, s_k that generate the unit ideal of A , such that M_{s_i} is a free A_{s_i} -module for each i . The free modules M_{s_i} will have the same rank. That rank is the *rank* of the locally free A -module M .

An ideal I of A is *locally principal* if there are elements s_i that generate the unit ideal, such that, for every i , I_{s_i} is a principal ideal of A_{s_i} . A locally principal ideal is a locally free module of rank one. □

5.2.12. Corollary. Let M be a finite module over a finite-type domain A . If for some point p of $X = \text{Spec } A$ the localized module M_p (5.1) is a free A_p -module, then there is an element s not in \mathfrak{m}_p such that M_s is a free A_s -module.

proof. This is an example of the general principle (2.6.10). □

We finish the proof of Proposition 5.2.4 now, by showing that every valuation v of the function field $K = \mathbb{C}(t)$ of \mathbb{P}^1 corresponds to a point of \mathbb{P}^1 .

Let R be the valuation ring of v . If $v(t) < 0$, we replace t by t^{-1} . So we may assume that $v(t) \geq 0$. Then t is an element of R , and therefore $\mathbb{C}[t] \subset R$. The maximal ideal M of R isn't zero. It contains a nonzero element of K , a fraction f/g of polynomials in t . The denominator g is in R , so M also contains the nonzero polynomial f . Since M is a prime ideal, it contains a monic irreducible factor of f , which will have the form $t - a$ for some complex number a . When $c \neq a$, the scalar $c - a$ isn't in M , so $t - c$ won't be in M . Since R is a local ring, $t - c$ must be a unit of R for all $c \neq a$. The localization R_0 of $\mathbb{C}[t]$ at the point $t = a$ is a valuation ring that is contained in the valuation ring R (5.2.4). There is no ring properly containing R_0 except K , so $R_0 = R$. □

Section 5.3 Smooth Curves

A *curve* is a variety of dimension 1. The proper closed subsets of a curve are the nonempty finite subsets.

5.3.1. Definition. A point p of a curve X is a *smooth point* if the local ring at p is a valuation ring. Otherwise, p is a *singular point*. A curve X is *smooth* if all of its points are smooth.

Let p be a smooth point of a curve X , and let v_p be the corresponding valuation. As with any valuation, we say that a rational function α on X has a *zero of order* $k > 0$ at p if $v_p(\alpha) = k$, and that it has a *pole of order* k at p if $v_p(\alpha) = -k$.

5.3.2. Lemma. (i) An affine curve X is smooth if and only if its coordinate algebra is a normal domain.
(ii) A curve has finitely many singular points.
(iii) The normalization $X^\#$ of a curve X is a smooth curve, and the finite morphism $X^\# \rightarrow X$ becomes an isomorphism when singular points of X and their inverse images are deleted.

proof. (i) This follows from Theorem 5.2.6 and Proposition 4.3.4.

(ii) The statement that a morphism is an isomorphism is verified locally, so we may replace X by an affine open subset, say $\text{Spec } A$. Then there is a nonzero element s in A such that $sA^\# \subset A$ (Corollary 4.3.2). Then $A_s = A_s^\#$. So $\text{Spec } A_s$, which is the complement of a finite set in $\text{Spec } A$, is smooth.

We omit the verification of (iii). □

5.3.3. Proposition. Let X be a smooth curve with function field K . Every point of \mathbb{P}^n with values in K defines a morphism $X \rightarrow \mathbb{P}^n$.

proof. Let v_p denote the valuation that corresponds to a point p of X . A point $(\alpha_0, \dots, \alpha_n)$ of \mathbb{P}^n with values in K determines a morphism $X \rightarrow \mathbb{P}^n$ if and only if, for every point p of X , there is an index j such that the functions α_i/α_j are regular at p for all $i = 0, \dots, n$ (3.5.6). This will be true when j is chosen so that the order of zero $v_p(\alpha_j)$ of α_j at p is the minimal integer among the orders of zero of α_i , for those indices i such that $\alpha_i \neq 0$. \square

As the next example shows, this proposition cannot be extended to varieties X of dimension greater than one.

5.3.4. Example. Let Y be the complement of the origin in the affine plane $X = \text{Spec } \mathbb{C}[x, y]$, and let $K = \mathbb{C}(x, y)$ be the function field of X . The vector (x, y) defines a point of $\mathbb{P}^1_{x,y}$ with values in K . This point can be written as $(1, y/x)$ and also as $(x/y, 1)$. So (x, y) defines a morphism to \mathbb{P}^1 wherever at least one of the functions x/y or y/x is regular, which is true at all points of Y . To extend the morphism to X , one would need an element λ in K such that λx and λy are both regular at $(0, 0)$ and not both zero there. There is no such element, so the morphism doesn't extend to X . \square

5.3.5. Proposition. *Let $X = \text{Spec } A$ be a smooth affine curve with function field K . The local rings of X are the valuation rings of K that contain A . Therefore the maximal ideals of A are locally principal.*

proof. Since A is a normal domain of dimension one, its local rings are valuation rings that contain A (see Theorem 5.2.6) and (5.2.10)). Let R be a valuation ring of K that contains A , let v be the associated valuation, and let M be the maximal ideal of R . The intersection $M \cap A$ is a prime ideal of A (2.1.2). Since A has dimension 1, the zero ideal is the only prime ideal of A that isn't a maximal ideal. We can clear the denominator of an element of M , multiplying by an element of R , to obtain an element of A while staying in M . So $M \cap A$ isn't the zero ideal. It is the maximal ideal \mathfrak{m}_p of A at a point p of X . The elements of A that aren't in \mathfrak{m}_p aren't in M either, so they are invertible in R . So the local ring A_p at p , which is a valuation ring, is contained in R , and therefore it is equal to R ((5.2.5) (iii)). \square

5.3.6. Proposition. *Let X' and X be smooth curves with the same function field K .*

- (i) *A morphism $X' \xrightarrow{f} X$ that is the identity on the function field K maps X' isomorphically to an open subvariety of X .*
- (ii) *If X is projective, X' is isomorphic to an open subvariety of X .*
- (iii) *If X' and X are both projective, they are isomorphic.*
- (iv) *If X is projective, every valuation ring of K is the local ring at a point of X .*

proof. (i) Let p be the image in X of a point q of X' , let U be an affine open neighborhood of p , and let V be an affine open neighborhood of q that is contained in the inverse image of U . Say $U = \text{Spec } A$ and $V = \text{Spec } B$. The morphism f gives us a homomorphism $A \rightarrow B$, and since q maps to p , this homomorphism extends to an inclusion of local rings $A_p \subset B_q$. They are valuation rings with the same field of fractions, so they are equal. Since B is a finite-type algebra, there is an element s in A , with $s(q) \neq 0$, such that $A_s = B_s$. Then the open subsets $\text{Spec } A_s$ of X and $\text{Spec } B_s$ of X' are the same. Since the point q is arbitrary, X' is covered by open subvarieties of X . So X' is an open subvariety of X .

(ii) The projective embedding $X \subset \mathbb{P}^n$ is defined by a point $(\alpha_0, \dots, \alpha_n)$ with values in K , and that same point defines a morphism $X' \rightarrow \mathbb{P}^n$. If $f(x_0, \dots, x_n) = 0$ is a set of defining equations of X in \mathbb{P}^n , then $f(\alpha) = 0$ in K , and therefore f vanishes on X' too. So the image of X' is contained in the zero locus of f , which is X . Then (i), applied to the morphism $\phi : X' \rightarrow \mathbb{P}^n$, shows that X' is an open subvariety of X .

(iii) This follows from (ii).

(iv) The local rings of X are normal and of dimension one, so they are valuation rings of K . We prove the converse. Let $\beta = (\beta_0, \dots, \beta_n)$ be the point with values in K that defines the projective embedding of X , let R be a valuation ring of K , and let v be the corresponding valuation. We order the coordinates so that $v(\beta_0)$ is minimal. Then the ratios $\gamma_j = \beta_j/\beta_0$ will be in R . The coordinate algebra A_0 of the affine variety $X^0 = X \cap \mathbb{U}^0$ is generated by the coordinate functions γ_j , so $A_0 \subset R$. Proposition 5.3.5 tells us that R is the local ring of X^0 at some point. \square

5.3.7. Proposition. *Let $X = \text{Spec } A$ be an affine curve, let \mathfrak{m} and v be the maximal ideal and valuation, respectively, at a smooth point p of X , and let t be an element of A with value 1. The valuation ring R of v is the local ring of A at p .*

(i) The power \mathfrak{m}^k consists of the elements of A whose values are at least k . If I is an ideal of A whose radical is \mathfrak{m} , then $I = \mathfrak{m}^k$ for some $k > 0$.

(ii) The algebras A/\mathfrak{m}^n and R/M^n are isomorphic to the truncated polynomial ring $\mathbb{C}[t]/(t^n)$.

(iii) If X is a smooth affine curve, every nonzero ideal I of A is a product $\mathfrak{m}_1^{e_1} \cdots \mathfrak{m}_k^{e_k}$ of powers of maximal ideals.

proof. (i) We refer to Proposition 5.2.5. The nonzero ideals of R are powers of its maximal ideal M , and the power M^k is the set of elements of R with value $\geq k$.

Let I be an ideal of A whose radical is \mathfrak{m} , and let k be the minimal value $v(x)$ of the nonzero elements x of I . We will show that I is the set of all elements of A with value $\geq k$, i.e., that $I = M^k \cap A$. Since we can apply the same reasoning to \mathfrak{m}^k , it will follow that $I = \mathfrak{m}^k$.

We must show that if an element y of A has value $v(y) \geq k$, then it is in I . We choose an element x of I with value k . Then x divides y in R , say $y/x = u$, with u in R . The element u will be a fraction a/s with s and a in A , s not in \mathfrak{m} , and $sy = ax$. The element s will vanish at a finite set of points q_1, \dots, q_r , but not at p . We choose an element z of A that vanishes at p but not at any of the points q_1, \dots, q_r . Then z is in \mathfrak{m} , and since the radical of I is \mathfrak{m} , some power of z is in I . We replace z by that power, so that z is in I . By our choice, z and s have no common zeros in X . They generate the unit ideal of A , say $1 = cs + dz$ with c and d in A . Then $y = csy + dzy = cax + dzy$. Since x and z are in I , so is y .

(ii) Since p is a smooth point, the local ring of A at p is the valuation ring R . Let t be an element of R with value 1, and let P be the subring $\mathbb{C}[t]$ of A , and let $\overline{P}_k = P/t^k P$, $\overline{A}_k = A/\mathfrak{m}^k$, and $\overline{R}_k = R/M^k$. Since \mathfrak{m} isn't the zero ideal, $\mathfrak{m}^{k-1} < \mathfrak{m}^k$ (Corollary 4.1.6). It follows from (i) that $t\mathfrak{m}^{k-1} = \mathfrak{m}^k$. Therefore $\mathfrak{m}^{k-1}/\mathfrak{m}^k$ is a one-dimensional vector space. The map labelled g_{k-1} in the diagram below is bijective.

$$\begin{array}{ccccccc} 0 & \longrightarrow & t^{k-1}P/t^k P & \longrightarrow & \overline{P}_k & \longrightarrow & \overline{P}_{k-1} \longrightarrow 0 \\ & & g_{k-1} \downarrow & & f_k \downarrow & & f_{k-1} \downarrow \\ 0 & \longrightarrow & \mathfrak{m}^{k-1}/\mathfrak{m}^k & \longrightarrow & \overline{A}_k & \longrightarrow & \overline{A}_{k-1} \longrightarrow 0 \end{array}$$

By induction on k , we may assume that the map f_{k-1} is bijective, and then f_k is bijective too. The same argument shows that \overline{P}_k and \overline{R}_k are isomorphic

(iii) Let I be a nonzero ideal of A . Because X has dimension one, the locus of zeros of I is a finite set $\{p_1, \dots, p_k\}$. Therefore the radical of I is the intersection $\mathfrak{m}_1 \cap \cdots \cap \mathfrak{m}_k$ of the maximal ideals \mathfrak{m}_j at p_j , which, by the Chinese Remainder Theorem, is the product ideal $\mathfrak{m}_1 \cdots \mathfrak{m}_k$. Moreover, I contains a power of that product, say $I \supset \mathfrak{m}_1^N \cdots \mathfrak{m}_k^N$. Let $J = \mathfrak{m}_1^N \cdots \mathfrak{m}_k^N$. The quotient algebra A/J is the product $B_1 \times \cdots \times B_k$, with $B_j = A/\mathfrak{m}_j^N$, and A/I is a quotient of A/J . Proposition 2.1.8 tells us that A/I is a product $\overline{A}_1 \times \cdots \times \overline{A}_k$, where \overline{B}_j is a quotient of B_j . By part (ii), each B_j is a truncated polynomial ring. So the quotients \overline{A}_j are also truncated polynomial rings, and the kernel of the map $A \rightarrow A_j$ is a power of \mathfrak{m}_j . Then the kernel I of the map $A \rightarrow \overline{A}_1 \times \cdots \times \overline{A}_k$ is a product of powers of the maximal ideals \mathfrak{m}_j . \square

jacobtwo

(5.3.8) isolated points

noisolat-
edpt

5.3.9. Proposition. *In the classical topology, a curve, smooth or not, contains no isolated point.*

This was proved before for plane curves (Proposition 1.3.18).

isolptofy

5.3.10. Lemma.

(i) Let Y' be an open subvariety of a variety Y . A point q of Y' is an isolated point of Y if and only if it is an isolated point of Y' .

(ii) Let $Y' \xrightarrow{u'} Y$ be a nonconstant morphism of curves, let q' be a point of Y' , and let q be its image in Y . If q is an isolated point of Y , then q' is an isolated point of Y' .

proof. (i) A point q of Y is isolated if the set $\{q\}$ is open in Y . If $\{q\}$ is open in Y' and Y' is open in Y , then $\{q\}$ is open in Y , and if $\{q\}$ is open in Y , it is open in Y' .

(ii) Because Y' has dimension one, the fibre over q will be a finite set, say $\{q'\} \cup F$, where F is the finite set of points of the fibre distinct from q . Let Y'' denote the (open) complement $Y' - F$ of F in Y' , and let u'' be the restriction of u' to Y'' . The fibre of Y'' over q is the point q' . If $\{q\}$ is open in Y , then because u'' is continuous, $\{q'\}$ will be open in Y'' , and by **9i**), it is open in Y' . \square

proof of Proposition 5.3.9. Let q be a point of a curve Y . Part **(i)** of Lemma 5.3.10 allows us to replace Y by an affine neighborhood of q . Let Y' be the normalization of Y . Part **(ii)** of that lemma allows us to replace Y by Y' . So we may assume that Y is a smooth affine curve, say $Y = \text{Spec } B$. We can still replace Y by an open neighborhood of q , so we may assume that the maximal ideal \mathfrak{m}_q at q is a principal ideal (5.3.5).

Say that $B = \mathbb{C}[x_1, \dots, x_n]/(f_1, \dots, f_k)$, that q is the origin $(0, \dots, 0)$ in \mathbb{A}_x^n , and that \mathfrak{m}_q is generated by the residue of a polynomial f_0 in B . Then f_0, \dots, f_k generate the maximal ideal $M = (x_1, \dots, x_n)$ of $\mathbb{C}[x]$ at the origin. Let's write $f_i = \sum_1^n c_{ij}x_j + O(2)$, where $O(2)$ denotes an undetermined polynomial all of whose terms have degree ≥ 2 in x . The coefficient c_{ij} is the partial derivative $\frac{\partial f_i}{\partial x_j}$, evaluated at q . So if J denotes the $(k+1) \times n$ Jacobian matrix $(\frac{\partial f_i}{\partial x_j})$, then $(f_0, \dots, f_k)^t = Jx^t + O(2)$, $x = (x_1, \dots, x_n)$. Since f_0, \dots, f_k generate M , there is a matrix P with polynomial entries such that $Pf^t = x^t$. Then $x^t = PJx^t + O(2)$. If P_0 and J_0 are the constant terms of P and J , P_0J_0 will be the identity matrix. So J_0 has rank n .

Let J'_0 be the matrix obtained by deleting the column with index 0 from J_0 . This matrix has rank at least $n - 1$, and we may arrange indices so that the submatrix with indices $1 \leq i, j \leq n - 1$ is invertible. The Implicit Function Theorem says that the equations f_1, \dots, f_{n-1} can be solved for the variables x_1, \dots, x_{n-1} as analytic functions of x_n , for small x_n . The locus Z of zeros of f_1, \dots, f_{n-1} is locally homeomorphic to the affine x_n -line (1.4.18), and it contains Y . Since Y has dimension 1, the component of Z that contains q must be equal to Y . So Y is locally homeomorphic to \mathbb{A}^1 , which has no isolated point. Therefore q isn't an isolated point of Y . \square

Section 5.4 Constructible Sets

In this section, X will denote a noetherian topological space, so every closed subset of X is a finite union of irreducible closed sets (2.2.15). A *constructible set* is a set that is the union of finitely many locally closed sets.

construct

The intersection $L = C \cap U$ of a closed set C and an open set U is called a *locally closed set*. For example, open sets and closed sets are locally closed.

5.4.1. Lemma. *The following conditions on a subset L of A are equivalent.*

lclosed-cond

- L is locally closed.
- L is a closed subset of an open subset U of X .
- L is an open subset of a closed subset C of X . \square

5.4.2. Examples.

constrin-curve

(i) A subset S of a curve X is constructible if and only if it is either a finite set or the complement of a finite set. Thus S is constructible if and only if it is either closed or open.

(ii) Let C be the line $\{y = 0\}$ in the affine plane $X = \text{Spec } \mathbb{C}[x, y]$, let $U = X - C$ be its open complement, and let $p = (0, 0)$. The union $U \cup \{p\}$ is constructible, but not locally closed. \square

We will use the following notation: C will denote a closed set, L will denote a locally closed set, and U will denote an open set.

5.4.3. Theorem. *The set \mathbb{S} of constructible subsets of a noetherian topological space X is the smallest family of subsets that contains the open sets and is closed under the three operations of finite union, finite intersection, and complementation.*

defloc-closed

proof. Let \mathbb{S}_1 denote the family of subsets obtained from the open sets by the three operations mentioned in the statement. Open sets are constructible, and using those three operations, one can make any constructible set from the open sets. So $\mathbb{S} \subset \mathbb{S}_1$. To show that $\mathbb{S} = \mathbb{S}_1$, we show that the family of constructible sets is closed under the three operations.

It is obvious that a finite union of constructible sets is constructible. The intersection of two locally closed sets $L_1 = C_1 \cap U_1$ and $L_2 = C_2 \cap U_2$ is locally closed because $L_1 \cap L_2 = (C_1 \cap C_2) \cap (U_1 \cap U_2)$. If

$S = L_1 \cup \cdots \cup L_k$ and $S' = L'_1 \cup \cdots \cup L'_r$ are constructible sets, the intersection $S \cap S'$ is the union of the locally closed intersections $(L_i \cap L'_j)$, so it is constructible.

Let S be the constructible set $L_1 \cup \cdots \cup L_k$. Its complement S^c is the intersection of the complements L_i^c of L_i : $S^c = L_1^c \cap \cdots \cap L_k^c$. We have shown that intersections of constructible sets are constructible. So to show that the complement S^c is constructible, it suffices to show that the complement of a locally closed set is constructible. Let L be the locally closed set $C \cap U$, and let C^c and U^c be the complements of C and U , respectively. Then C^c is open and U^c is closed. The complement L^c of L is the union $C^c \cup U^c$ of constructible sets, so it is constructible. \square

contain-
sopen

5.4.4. Proposition. *In a noetherian topological space X , every constructible subset is a union $L_1 \cup \cdots \cup L_k$ of locally closed sets: $L_i = C_i \cap U_i$, in which the closed sets C_i are irreducible and distinct.*

proof. Let $L = C \cap U$ be a locally closed set, and let $C = C_1 \cup \cdots \cup C_r$ be the decomposition of C into irreducible components. Then $L = (C_1 \cap U) \cup \cdots \cup (C_r \cap U)$, which is constructible. So every constructible set S is a union of locally closed sets $L_i = C_i \cap U_i$ in which the C_i are irreducible. Next, suppose that two of the irreducible closed sets are equal, say $C_1 = C_2$. Then $L_1 \cup L_2 = (C_1 \cap U_1) \cup (C_1 \cap U_2) = C_1 \cap (U_1 \cup U_2)$ is locally closed. So we can find an expression in which the closed sets are also distinct. \square

sinx

5.4.5. Lemma.

(i) *Let X_1 be a closed subset of a variety X , and let X_2 be its open complement. A subset S of X is constructible if and only if $S \cap X_1$ and $S \cap X_2$ are constructible.*

(ii) *Let X' be an open or a closed subvariety of a variety X .*

a) *If S is a constructible subset of X , then $S' = S \cap X'$ is a constructible subset of X' .*

b) *A subset S' of X' is a constructible subset of X' if and only if it is a constructible subset of X .*

proof. (i) This follows from Theorem 5.4.3.

(iia) It suffices to prove that the intersection $L' = L \cap X'$ of a locally closed subset L of X is a locally closed subset of X' . If $L = C \cap U$, then $C' = C \cap X'$ is closed in X' , and $U' = U \cap X'$ is open in X' . So $L' = C' \cap U'$ is locally closed.

(iib) It follows from (iia) that if a subset S' of X' is constructible in X , then it is constructible in X' . To show that a constructible subset of X' is constructible in X , it suffices to show that a locally closed subset $L' = C' \cap U'$ of X' is locally closed in X . If X' is closed in X , then C' is closed in X , and $U' = X \cap U$ for some open subset U of X . Since $C' \subset X'$, $L' = C' \cap U' = C' \cap X' \cap U = C' \cap U$, which is locally closed in X . If X' is open in X , then U' is open in X . Let C be the closure of C' in X . Then $L' = C \cap U' = C \cap X' \cap U' = C' \cap U'$. Again, L' is locally closed in X . \square

The next theorem illustrates a general fact, that sets arising in algebraic geometry are often constructible.

imagecon-
str

5.4.6. Theorem. *Let $Y \xrightarrow{f} X$ be a morphism of varieties. The inverse image of a constructible subset of X is a constructible subset of Y . The image of a constructible subset of Y is a constructible subset of X .*

proof. The fact that a morphism is continuous implies that the inverse image of a constructible set is constructible. To prove that the image of a constructible set is constructible, one keeps reducing the problem until there is nothing left to do.

Let S be a constructible subset of Y . Lemma 5.4.5 and Noetherian induction allow us to assume that the theorem is true when S is contained in a proper closed subvariety of Y , and also when its image $f(S)$ is contained in a proper closed subvariety of X .

Suppose that X is the union of a proper closed subvariety X_1 and its open complement X_2 . The inverse image $Y_1 = f^{-1}(X_1)$ will be closed in Y , and its open complement will be the inverse image $Y_2 = f^{-1}(X_2)$. A constructible subset S of Y is the union of the constructible sets $S_1 = S \cap Y_1$ and $S_2 = S \cap Y_2$, and $f(S) = f(S_1) \cup f(S_2)$. It suffices to show that $f(S_1)$ and $f(S_2)$ are constructible, and to show this, it suffices to show that $f(S_i)$ is a constructible subset of X_i for $i = 1, 2$ (5.4.5) (iib). Moreover, noetherian induction applies to X_1 . So we need only show that $f(S_2)$ is a constructible subset of X_2 . This means that we can replace X by X_2 , which is an arbitrary nonempty open subset, and Y by its inverse image, which is open.

Next, suppose that Y is the union of a proper closed subvariety Y_1 and its open complement Y_2 , and let $S_i = S \cap Y_i$. It suffices to show that $f(S_i)$ is constructible, for $i = 1, 2$, and induction applies to S_1 . So we may replace Y by any nonempty open subvariety.

Summing up, we can replace X by any nonempty open subset X' , and Y by any nonempty open subset Y' that is contained in the inverse image of X' . We can do this finitely often.

Since S is a finite union of locally closed sets, it suffices to treat the case that S is locally closed. Moreover, we may suppose that $S = C \cap U$, where C is irreducible. Then Y is the union of the closed subset $C = Y_1$ and its complement Y_2 , and $S \subset Y$. Then $S \cap Y_2 = \emptyset$, and we may replace Y by Y_1 . By rearranging rows, we may assume that $S = Y \cap U = U$, and we may replace Y by U . We are thus reduced to the case that $S = Y$.

We may still replace X and Y by nonempty open subsets, so we may assume that they are affine, say $Y = \text{Spec } B$ and $X = \text{Spec } A$. Then the morphism $Y \rightarrow X$ corresponds to an algebra homomorphism $A \xrightarrow{\varphi} B$. If the kernel I of φ were nonzero, the image of Y would be contained in the proper closed subset $\text{Spec } A/I$ of X , to which induction would apply. So we may assume that φ is injective.

Corollary 4.2.10 tells us that, for suitable nonzero s in A , B_s will be a finite module over a polynomial subring $A_s[y_1, \dots, y_k]$. Then with $Y_s = \text{Spec } B_s$ and $X_s = \text{Spec } A_s$, the maps $Y_s \rightarrow \text{Spec } A_s[y]$ and $\text{Spec } A_s[y] \rightarrow X_s$ are both surjective, so Y_s maps surjectively to X_s . When we replace X and Y by X_s and Y_s , the map $Y \rightarrow X$ becomes surjective, and we are done. \square

Section 5.5 Closed Sets

Limits of sequences are often used to analyze subsets of a topological space. In the classical topology, a subset Y of \mathbb{C}^n is closed if, whenever a sequence of points in Y has a limit in \mathbb{C}^n , the limit is in Y . In algebraic geometry, curves can be used as substitutes for sequences.

We use the following notation:

(5.5.1)

C denotes a smooth affine curve, q is a point of C , and C' denotes the complement of q in C .

The closure of C' will be C , and we think of q as a limit point. Theorem 5.5.3, which is below, asserts that a constructible subset of a variety is closed if it contains all such limit points.

The next theorem tells us that there are enough curves to do the job.

5.5.2. Theorem. (enough curves) *Let Y be a constructible subset of a variety X , and let p be a point of its closure \overline{Y} . There exists a morphism $C \xrightarrow{f} X$ from a smooth affine curve to X , and a point q of C with $f(q) = p$, such that the image of $C' = C - \{q\}$ is contained in Y .*

proof. If $X = p$, then $Y = p$ too. In this case, we may take for f the constant morphism from any curve C to p . So we may assume that X has dimension at least one. Next, we may replace X by an affine open subset X' that contains p , and Y by $Y' = Y \cap X'$. This is because the closure $\overline{Y'}$ of Y' in X' will be the intersection $\overline{Y} \cap X'$, and it will contain p . So we may assume that X is affine, say $X = \text{Spec } A$.

Since Y is constructible, it is a union $L_1 \cup \dots \cup L_k$ of locally closed sets, say $L_i = Z_i \cap U_i$ where Z_i are irreducible closed sets and U_i are open sets. (We use Z_i in place of C_i here, to avoid confusion with a curve.) The closure of Y is the union $Z_1 \cup \dots \cup Z_k$, and p will be in at least one of those closed sets, say $p \in Z_i$. We replace X by Z_i and Y by L_i . This reduces us to the case that Y is a nonempty open subset of X .

We use Krull's Theorem to slice X down to dimension 1. Suppose that the dimension n of X is at least two. Let $D = X - Y$ be the (closed) complement of the open set Y . The components of D have dimension at most $n - 1$. We choose an element α of the coordinate algebra A of X that is zero at p and isn't identically zero on any component of D , except at p itself, if p happens to be a component. (If $\alpha_1, \dots, \alpha_k$ are generators for the maximal ideal of A at p , a linear combination $\alpha = c_1\alpha_1 + \dots + c_k\alpha_k$ with c_1, \dots, c_k generic scalars will have this property.) Krull's Theorem tells us that every component of the zero locus of α has dimension $n - 1$, and at least one of those components, call it V , contains p . If V were contained in D , it would be a component of D because $\dim V = n - 1$ and $\dim D \leq n - 1$. By our choice of α , this isn't the case. So $V \not\subset D$, and therefore $V \cap Y \neq \emptyset$. Because V is irreducible and Y is open, $W = V \cap Y$ is a dense open subset of V , and p is a point of its closure V . We replace X by V and Y by W . The dimension of X is thereby reduced to $n - 1$.

Thus it suffices to treat the case that X has dimension one. In this case, X will be a curve that contains p and Y will be a nonempty open subset of X . The normalization of X will be a smooth curve X_1 that comes with an integral, and therefore surjective, morphism to X . Finitely many points of X_1 will map to p . We choose for C an affine open subvariety of X_1 that contains just one of those points, and we call that point q . \square

us-
ingcurves

Cwith-
point

enoughcurves

closed-crittwo

5.5.3. Theorem (curve criterion for a closed set) Let Y be a constructible subset of a variety X . The following conditions are equivalent:

(a) Y is closed.

(b) For every morphism $C \xrightarrow{f} X$ from a smooth affine curve to X , the inverse image $f^{-1}Y$ is closed in C .

(c) Let q be a point of a smooth affine curve C , let $C' = C - \{q\}$, and let $C \xrightarrow{f} X$ be a morphism. If $f(C') \subset Y$, then $f(C) \subset Y$.

The hypothesis that Y be constructible is necessary. For example, in the affine line X , the set Z of points with integer coordinates isn't constructible, but it satisfies the curve criterion (b). Any morphism $C' \rightarrow X$ whose image is in Z will map C' to a single point, and therefore it will extend to C .

proof. The implications (a) \Rightarrow (b) \Rightarrow (c) are obvious. We prove the contrapositive of the implication (c) \Rightarrow (a). Suppose that Y isn't closed. We choose a point p of the closure \bar{Y} that isn't in Y , and we apply Theorem 5.5.2. There exists a morphism $C \xrightarrow{f} X$ from a smooth curve to X and a point q of C such that $f(q) = p$ and $f(C') \subset Y$. Since $q \notin Y$, this morphism shows that (c) doesn't hold either. \square

class-closed

5.5.4. Theorem. A constructible subset Y of a variety X is closed in the Zariski topology if and only if it is closed in the classical topology.

proof. A Zariski closed set is closed in the classical topology because the classical topology is finer than the Zariski topology.

Suppose that Y is closed in the classical topology. Let z be a point of the Zariski closure \bar{z} of Y , and let $C \xrightarrow{f} X$ be a morphism from a smooth affine curve to X that maps the complement C' of z to Y . Let $Y_1 = f^{-1}Y$. Then Y_1 contains C' , so Y_1 is either C' or C . A morphism is a continuous map in the classical topology. Since Y is closed in the classical topology, Y_1 is closed in C . If Y_1 were equal to C' , then $\{z\}$ would be open as well as closed. It would be an isolated point of C . Since a curve contains no isolated point, the closure is C . Therefore the curve criterion (5.5.3) is satisfied, and Y is closed in the Zariski topology. \square

Section 5.6 Fibred Products

fibprod
mapprop-
prod

(5.6.1) the mapping property of a product

The product $X \times Y$ of two sets X and Y has a mapping property that is easy to verify: Maps from a set T to the product set $X \times Y$, correspond bijectively to pairs of maps $T \xrightarrow{f} X$ and $T \xrightarrow{g} Y$. The map $T \xrightarrow{(f,g)} X \times Y$ defined by the pair of maps f, g sends a point t to the point pair $(f(t), g(t))$.

Let $X \times Y \xrightarrow{\pi_1} X$ and $X \times Y \xrightarrow{\pi_2} Y$ denote the projection maps. If $T \xrightarrow{h} X \times Y$ is a map to the product, the corresponding maps to X and Y are the compositions with the projections: $T \xrightarrow{\pi_1 h} X$ and $T \xrightarrow{\pi_2 h} Y$:

The analogous statements are true for morphisms of varieties.

mapprop-
var

5.6.2. Proposition. Let X and Y be varieties, and let $X \times Y$ be the product variety.

(i) The projections $X \times Y \xrightarrow{\pi_1} X$ and $X \times Y \xrightarrow{\pi_2} Y$ are morphisms.

(ii) Morphisms from a variety T to the product variety $X \times Y$ correspond bijectively to pairs of morphisms $T \rightarrow X$ and $T \rightarrow Y$, the correspondence being the same as for maps of sets.

(iii) If $X \xrightarrow{f} Z$ and $Y \xrightarrow{g} W$ are morphisms of varieties, the product map $X \times Y \xrightarrow{f \times g} Z \times W$, which is defined by $[f \times g](x, y) = (f(x), g(y))$, is a morphism. \square

fibprod-
sets

(5.6.3) fibred products of sets

If $X \xrightarrow{f} Z$ and $Y \xrightarrow{g} Z$ are maps of sets, the *fibred product* $X \times_Z Y$ is the subset of the product $X \times Y$ consisting of pairs of points x, y such that $f(x) = g(y)$. It fits into a diagram

fprod-diagr

$$(5.6.4) \quad \begin{array}{ccc} X \times_Z Y & \xrightarrow{\pi_2} & Y \\ \pi_1 \downarrow & & g \downarrow \\ X & \xrightarrow{f} & Z \end{array}$$

in which π_1 and π_2 are the projections. Many important subsets of a product can be described as fibred products. Foreexample, if a map $Y \rightarrow Z$ is given, and if $p \rightarrow Z$ is the inclusion of a point into Z , then $p \times_Z Y$ is the fibre of Y over p . The diagonal in $X \times X$ is the fibred product $X \times_X X$. And, given a map $Y \xrightarrow{f} X$ fits into a diagram

$$\begin{array}{ccc} \Gamma_f & \longrightarrow & Y \\ id \downarrow & & f \downarrow \\ X & \xlongequal{\quad} & X \end{array}$$

which identifies the graph Γ_f as a fibred product.

The reason for the term “fibred product” is that $X \times_Z Y$ is the union of the products $X_z \times Y_z$ of the fibres X_z and Y_z over points z of Z : $X \times_Z Y = \bigcup_z X_z \times Y_z$.

(5.6.5) fibred products of varieties

fibprodvar

Since we are working with varieties, not schemes, we have a small problem: A fibred product of varieties will be a scheme, but it needn't be a variety.

5.6.6. Example. Let $X = \text{Spec } \mathbb{C}[x]$, $Y = \text{Spec } \mathbb{C}[y]$ and $Z = \text{Spec } \mathbb{C}[z]$ be affine lines, let $X \xrightarrow{f} Z$ and $Y \xrightarrow{g} Z$ be the maps defined by $z = x^2$ and $z = y^2$, respectively. The fibred product $X \times_Z Y$ is the closed subset of the affine x, y -plane consisting of points (x, y) such that $x^2 = y^2$. It is the union of the two lines $x = y$ and $x = -y$. \square

examplefi-
bredprod-
uct

The next proposition will be enough for our purposes.

5.6.7. Proposition. Let $X \xrightarrow{f} Z$ and $Y \xrightarrow{g} Z$ be morphisms of varieties. The fibred product $X \times_Z Y$ is a closed subset of the product variety $X \times Y$.

fibprod-
closed

5.6.8. Lemma. Let u and v be two morphisms of varieties $X \rightarrow Z$. The subset W of points x of X such that $u(x) = v(x)$ is closed in X .

equalizer

proof. In $X \times Z$, let W' be the intersection of the graphs of u and v : $W' = \Gamma_u \cap \Gamma_v$. A point (x, z) is in W' if $ux = z$ and $vx = z$. It is an intersection of closed sets, so it is closed in Γ_u (and in Γ_v). The projection $\Gamma_u \rightarrow X$, which is an isomorphism (3.5.23), carries W' to W , so W is closed in X .

poof of Proposition 5.6.7. The graph Γ_f of a morphism $X \xrightarrow{f} Z$ of varieties is a closed subvariety of $X \times Z$ isomorphic to X (Proposition 3.5.23). With reference to Diagram 5.6.4, $X \times_Z Y$ is the subset of the product $X \times Y$ of points at which the maps $f\pi_X$ and $g\pi_Y$ to Z are equal. The lemma shows that it is closed in $X \times Y$. \square

Section 5.7 Projective Varieties are Proper

proper

As has been noted before, an important property of projective space is that, in the classical topology, it is a compact space. A variety isn't compact in the Zariski topology unless it is a single point. However, in the Zariski topology, projective varieties have a property closely related to compactness: They are *proper*.

Before defining the concept of a proper variety, we explain an analogous property of compact spaces.

5.7.1. Corollary. Let X be a compact space, let Z be a Hausdorff space, and let V be a closed subset of $Z \times X$. The image of V via projection to Z is a closed subset of Z .

proper-
compact

proof. Let W be the image of V in Z . We show that if a sequence of points z_i of W has a limit \underline{z} in Z , then \underline{z} is in W . For each i , we choose a point p_i of V that lies over z_i . So p_i is a pair (z_i, x_i) , x_i being a point of X . Since X is compact, there is a subsequence of the sequence x_i that has a limit \underline{x} in X . Passing to a subsequence of $\{p_i\}$, we may suppose that x_i has limit \underline{x} . Then p_i will have the limit $\underline{p} = (\underline{z}, \underline{x})$. Since V is closed, \underline{p} is in V , and therefore \underline{z} is in its image W . \square

defproper **5.7.2. Definition.** A variety X is *proper* if it has the following property: Let $Z \times X$ be the product of another variety Z with X , let π_Z denote the projection $Z \times X \rightarrow Z$, and let V be a closed subvariety of $Z \times X$. The image $W = \pi_Z(V)$ of V in Z is a closed subvariety of Z .

imclos (5.7.3)

$$\begin{array}{ccc} V & \xrightarrow{\subset} & Z \times X \\ \downarrow & & \downarrow \pi_Z \\ W & \xrightarrow{\subset} & Z \end{array}$$

If X is proper, then because every closed set is a finite union of closed subvarieties, the image of any closed subset of $Z \times X$ will be a closed subset of Z ,

propim-closed **5.7.4. Proposition.** Let X be a proper variety, let V be a closed subvariety of X , and let $X \xrightarrow{f} Y$ be a morphism. The image $f(V)$ of V is a closed subvariety of Y .

proof. In $X \times Y$, the graph Γ_f of f is a closed subset isomorphic to X , and via this isomorphism, V corresponds to a subset V' of Γ_f that is closed in Γ_f and in $X \times Y$. The points of V' are pairs (x, y) such that $x \in V$ and $y = f(x)$. Since X is proper, the image of V' via projection to Y , which is $f(V)$, is closed. \square

pnproper **5.7.5. Theorem.** Projective varieties are proper.

This is the most important application of the use of curves to characterize closed sets.

proof. Let X be a projective variety. With notation as in Definition 5.7.2, suppose we are given a closed subvariety V of the product $Z \times X$. We must show that its image W is a closed subvariety of Z . If the image is a closed set, it will be irreducible. So it suffices to show that W is closed, and to do this, it suffices to show that W is closed in the classical topology (Theorem 5.5.4). Theorem 5.4.6 tells us that W is a constructible set, and since X is closed in projective space, it is compact in the classical topology. Proposition 5.7.1 tells us that W is closed in the classical topology. \square

needcover **5.7.6. Note.** Of course, since this is an algebraic theorem, one would prefer an algebraic proof. To make an algebraic proof, one could attempt to use the curve criterion, proceeding as follows: Given a closed subset V of $Z \times X$ with image W and a point p in the closure of W , one chooses a map $C \xrightarrow{f} Z$ from an affine curve C to Z such that $f(q) = p$ and $f(C') \subset W$, C' being the complement of p in C . Then one tries to lift this map, defining a morphism $C \xrightarrow{g} Z \times X$ such that $g(C') \subset V$ and $f = \pi \circ g$. Since V is closed, it would contain $g(q)$, and therefore $f(q) = \pi g(q)$ would be in $\pi(V) = W$. Unfortunately, to find g , it may be necessary to replace C by a curve that covers C . It isn't difficult to make this method work, but it takes longer. That is why we resorted to the classical topology. \square

The next examples show how Theorem 5.7.5 can be used.

properex **5.7.7. Example.** (*singular curves*) We parametrize the plane curves of a given degree d . The number of monomials $x_0^i x_1^j x_2^k$ of degree $d = i + j + k$ is the binomial coefficient $\binom{d+2}{2}$. We order those monomials arbitrarily, and label them as m_0, \dots, m_r , with $r = \binom{d+2}{2} - 1$. A homogeneous polynomial of degree d will be a combination $\sum z_i m_i$ of monomials with complex coefficients z_i , so the homogeneous polynomials f of degree d in x , taken up to scalar factors, are parametrized by the projective space of dimension r with coordinates z . Let's denote that projective space by Z . Points of Z correspond bijectively to divisors of degree d in the projective plane (1.3.12).

The product variety $Z \times \mathbb{P}^2$ represents pairs (D, p) , where D is a divisor of degree d and p is a point of \mathbb{P}^2 . A variable homogeneous polynomial of degree d in x will be a bihomogeneous polynomial $f(z, x)$ of degree 1 in z and degree d in x . For example, in degree 2, f will be

$$z_0 x_0^2 + z_1 x_1^2 + z_2 x_2^2 + z_3 x_0 x_1 + z_4 x_0 x_2 + z_5 x_1 x_2$$

So the locus $\Gamma: \{f(z, x) = 0\}$ in $Z \times \mathbb{P}^2$ is a closed set. Its points are pairs (D, p) such that D is the divisor of f and p is a point of D .

Let Σ be the set of pairs (D, p) such that p is a singular point of D . This is also a closed set. It is defined by the system of equations $f_0(z, x) = f_1(z, x) = f_2(z, x) = 0$, where f_i are the partial derivatives $\frac{\partial f}{\partial x_i}$. (Euler's Formula shows then that $f(x, z) = 0$.) The partial derivatives f_i are bihomogeneous, of degree 1 in z and degree $d-1$ in x . \square

The next proposition isn't especially easy to prove directly, but the proof becomes easy when one uses the fact that projective space is proper.

5.7.8. Proposition *The singular divisors of degree d , the divisors containing at least one singular point, form a closed subset S of the projective space Z of all divisors of degree d .*

singclosed

proof. The points of S are the images of points of the set Σ via projection to Z . Theorem 5.7.5 tells us that the image of Σ is closed. \square

5.7.9. Example. (*surfaces that contain a line*) We go back to the discussion of lines in a surface, as in (3.7). Let \mathbb{S} denote the projective space that parametrizes surfaces of degree d in \mathbb{P}^3 , as before.

surface-line

5.7.10. Proposition *In \mathbb{P}^3 , the surfaces of degree d that contain a line form a closed subset of the space \mathbb{S} .*

surfaceswith-line

The Grassmanian $\mathbb{G} = G(2, 4)$ of lines in \mathbb{P}^3 is a projective variety (Corollary 3.7.13). Let Ξ be the subset of $\mathbb{G} \times \mathbb{S}$ of pairs of pairs $[\ell], [S]$ such that $\ell \subset S$. Lemma 3.7.17 tells us that Ξ is a closed subset of $\mathbb{G} \times \mathbb{S}$. Therefore its image in \mathbb{S} is closed. \square

Section 5.8 Fibre Dimension

semicont

A function $Y \xrightarrow{\delta} \mathbb{Z}$ from a variety to the integers is *constructible* if, for every integer n , the set of points of Y such that $\delta(p) = n$ is constructible, and δ is *upper semicontinuous* if for every n , the set of points such that $\delta(p) \geq n$ is closed. For brevity, we refer to an upper semicontinuous function as *semicontinuous*, though the term is ambiguous. A function can also be lower semicontinuous.

A function δ on a curve C is semicontinuous if and only if there exists an integer n and a nonempty open subset C' of C such that $\delta(p) = n$ for all points $p \in C'$ and $\delta(p) \geq n$ for all $p \in C$.

The next curve criterion for semicontinuous functions follows from the criterion for closed sets.

5.8.1. Proposition. (*curve criterion for semicontinuity*) *Let Y be a variety. A function $Y \xrightarrow{\delta} \mathbb{Z}$ is semicontinuous if and only if it is a constructible function, and for every morphism $C \xrightarrow{f} Y$ from a smooth curve C to Y , the composition $\delta \circ f$ is a semicontinuous function on C .* \square

uppercrit

Let $Y \xrightarrow{f} X$ be a morphism of varieties, let q be a point of Y , and let Y_p be the fibre of f over $p = f(q)$. The *fibre dimension* $\delta(q)$ of f at q is the maximum among the dimensions of the components of the fibre that contain q .

Note. One could also define the fibre dimension of a point p of X to be the dimension of the fibre over p . This seems to be simpler. However, it is possible that a fibre contains components whose dimensions are distinct, and if so, the fibre dimension defined here is more precise.

5.8.2. Theorem. (*semicontinuity of fibre dimension*) *Let $Y \xrightarrow{u} X$ be a morphism of varieties, and let $\delta(q)$ denote the fibre dimension at a point q of Y .*

uppersemi

(i) *Suppose that X is a smooth curve, that Y has dimension n , and that u does not map Y to a single point. Then δ is constant – the fibres have constant dimension: $\delta(q) = n - 1$ for all $q \in Y$.*

(ii) *Suppose that the image of Y contains a nonempty open subset of X , and let the dimensions of X and Y be m and n , respectively. There is a nonempty open subset X' of X such that $\delta(q) = n - m$ for every point q in the inverse image of X' .*

(iii) *δ is a semicontinuous function on Y .*

The proof of this theorem is left as a long exercise. When you have done it, you will have understood the chapter.

Section 5.9 Exercises

chapfiveex

5.9.1. Prove that the ring $k[[x, y]]$ of formal power series with coefficients in a field k is a local ring and a unique factorization domain.

5.9.2. Prove that if A, B are finite-type domains, then $A \otimes B$ is a finite-type domain.

5.9.3. Let A be a normal finite-type domain. Prove that the localization A_P of A at a prime ideal P of codimension 1 is a valuation ring.

5.9.4. Let A be the polynomial ring $\mathbb{C}[x_1, \dots, x_n]$, and let P be the principal ideal generated by an irreducible polynomial $f(x_1, \dots, x_n)$. The local ring A_P consists of fractions g/h of polynomials in which g is arbitrary, and h can be any polynomial that isn't divisible by f . Describe valuation v associated to this local ring.

5.9.5. In the four dimensional space Z of 2×2 matrices, let X be the locus of idempotent matrices: $A^2 = A$. The general linear group GL_2 operates on X by conjugation.

(a) Decompose X into orbits for the operation of GL_2 , and prove that the orbits are closed subsets of Z .

(b) Show that the orbits are smooth by verifying the Jacobian criterion at a suitable point of each orbit.

xcount-cover

5.9.6. Prove that, if a variety X is covered by countably many constructible sets, a finite number of those sets will cover X .

xmiss-point

5.9.7. Let X be the subset obtained by deleting the origin from \mathbb{A}^2 . Prove that there is no injective morphism from an affine variety Y to \mathbb{A}^2 whose image is X .

xfconst

5.9.8. Show that if $f(x, y)$ is polynomial and if d divides f_x and f_y , then f is constant on the locus $d = 0$.

xsimple-loc

5.9.9. Let S be a multiplicative system in a finite-type domain R , and let A and B be finite-type domains that contain R as subring. Let R', A', B' be the rings of S -fractions of R, A, B , respectively. Prove:

(i) If a set of elements $\alpha_1, \dots, \alpha_k$ generates A as R -algebra, it also generates A' as R' -algebra.

(ii) Let $A' \xrightarrow{\varphi'} B'$ be a homomorphism. For suitable s in S , there is a homomorphism $A_s \xrightarrow{\varphi_s} B_s$ whose localization is φ' . If φ' is injective, so is φ_s . If φ' is surjective or bijective, there will be an s such that φ_s is surjective or bijective.

(iii) If A' is contained in B' and if B' is a finite A' -module, then for suitable s in S , A_s is contained in B_s , and B_s is a finite A_s -module.

singular-closed exupper

5.9.10. Prove Theorem 5.7.8 directly, without appealing to Theorem 5.7.5.

5.9.11. Is the constructibility hypothesis in 5.8.1 necessary?

5.9.12. Let S be a multiplicative system in a finite-type domain R , and let A and B be finite-type domains that contain R as subring. Let R', A', B' be the rings of S -fractions of R, A, B , respectively.

(i) If some elements $\alpha_1, \dots, \alpha_k$ of A generate A as R -algebra, they also generate A' as R' -algebra.

(ii) Let $A' \xrightarrow{\varphi'} B'$ be a homomorphism. For suitable s in S , there is a homomorphism $A_s \xrightarrow{\varphi_s} B_s$ whose localization is φ' . If φ' is injective, so is φ_s . If φ' is surjective or bijective, there will be an s such that φ_s is surjective or bijective.

(iii) If A' is contained in B' and if B' is a finite A' -module, then for suitable s in S , A_s is contained in B_s , and B_s is a finite A_s -module.

5.9.13. twisted cubic specializes to plane nodal cubic

5.9.14. With reference to Note 5.7.6, let $X = \mathbb{P}^1$ and $Z = \mathbb{A}^1 = \text{Spec } \mathbb{C}[t]$. Find a closed subset V of $Z \times X$ whose image is Z , such that the identity map $Z \rightarrow Z$ can't be lifted to a map $Z \rightarrow V$.

xsemicont

5.9.15. Prove that fibre dimension is a semicontinuous function. I recommend this outline, but you may use any method you like.

(a) We may assume that Y and X are affine, $Y = \text{Spec } B$ and $X = \text{Spec } A$.

(b) The theorem is true when $A \subset B$ and B is an integral extension of a polynomial subring $A[y_1, \dots, y_d]$.

(c) The fibre dimension is a constructible function.

(d) The theorem is true when X is a smooth curve.

(e) The theorem is true for all X .

Chapter 6 MODULES

- 6.1 The Structure Sheaf
- 6.2 \mathcal{O} -Modules
- 6.3 The Sheaf Property
- 6.4 Some \mathcal{O} -Modules
- 6.5 Direct Image
- 6.6 Support
- 6.7 Twisting
- 6.8 Proof of Theorem 6.3.2

This chapter explains how modules on a variety are defined. Before starting, we review a few facts about localization. Recall that, if s is a nonzero element of a domain A , the symbol A_s stands for the localization $A[s^{-1}]$, and if $X = \text{Spec } A$, then $X_s = \text{Spec } A_s$.

- Let s be a nonzero element of a domain A and let M be an A -module, the localized module M_s is the A_s -module whose elements are the equivalence classes of fractions ms^{-k} , $m \in M$. The localized module M_s becomes an A -module by restriction of scalars (5.1.12). A homomorphism $N \rightarrow M_s$ of A -modules extends in a natural way to a homomorphism of A_s -modules $N_s \rightarrow M_s$.
- Let $X = \text{Spec } A$ be an affine variety. The intersection of two localizations $X_s = \text{Spec } A_s$ and $X_t = \text{Spec } A_t$ is the localization $X_{st} = \text{Spec } A_{st}$.
- Let $W \subset V \subset U$ be affine open subsets of a variety X . If V is a localization of U and W is a localization of V , then W is a localization of U .
- The affine open subsets of a variety X form a basis for the topology on a variety X . The localizations of an affine variety form a basis for its topology.
- If U and V are affine open subsets of X , the open sets W that are localizations of U and localizations of V , form a basis for the topology on $U \cap V$.

See (2.6.2) for these assertions. We will use them without further comment.

Starting in this chapter, we also need to use the concepts of *category* and *functor*. If you aren't familiar with these concepts, please read about them. We won't need to know much. Learn the definitions and study a few examples.

Section 6.1 The Structure Sheaf.

strsh

We associate two categories to a variety X . The first is the category (*opens*). Its objects are the open subsets of X , and its morphisms are inclusions: If U and V are open sets and if $V \subset U$, there is a unique morphism $V \rightarrow U$ in (*opens*), and if $V \not\subset U$ there is no morphism $V \rightarrow U$.

We also introduce a subcategory (*affines*) of the category (*opens*). Its objects are the affine open subsets of X , and its morphisms are localizations. A morphism $V \rightarrow U$ in (*opens*) is a morphism in (*affines*) if U is affine and V is a localization of U , i.e., if V is an affine open subset of the form U_s , where s is a nonzero element of the coordinate algebra of U .

The *structure sheaf* \mathcal{O}_X on a variety X is the functor

strshdef (6.1.1) $(\text{affines})^\circ \xrightarrow{\mathcal{O}_X} (\text{algebras})$

n from affine open sets to algebras, that sends an affine open set $U = \text{Spec } A$ to its coordinate algebra A . When speaking of the structure sheaf, the coordinate algebra of U is denoted by $\mathcal{O}_X(U)$. Thus \mathcal{O}_X may be viewed as the inverse of the functor Spec .

If it is clear which variety is being studied, we may write \mathcal{O} for \mathcal{O}_X .

As has been noted before, inclusions $V \rightarrow U$ of affine open subsets needn't be localizations. We focus attention on localizations because the relation between the coordinate algebras of an affine variety and a localization is easy to understand. However, the structure sheaf extends with little difficulty to the category (*opens*), (See Corollary 6.1.2 below.)

A brief review about regular functions: The *function field* of a variety X is the field of fractions of the coordinate algebra of any one of its affine open subsets, and a *rational function* on X is an element of the function field. A rational function f is *regular* on an affine open set $U = \text{Spec } A$ if it is an element of A , and f is *regular* on a nonempty open set U if U can be covered by affine open sets on which it is regular. Thus the function field of a variety X contains the regular functions on every nonempty open subset, and the regular functions are governed by the regular functions on the affine open subsets.

Though an affine variety is determined by its regular functions, the regular functions don't suffice to determine a variety when it isn't affine. For instance, the only rational functions that are regular everywhere on the projective line \mathbb{P}^1 are the constant functions, which are useless. We will be interested in regular functions on non-affine open sets, especially in functions that are regular on the whole variety, but one should always work with the affine open sets, where the definition of a regular function is clear.

Let U and V be open subsets of a variety X , with $V \subset U$. If a rational function is regular on U , it is also regular on V . Thus if $V \subset U$ is an inclusion of affine open subsets, say $U = \text{Spec } A$ and $V = \text{Spec } B$, then $A \subset B$. However, it won't be clear how to construct B from A unless B is a localization. If $V = U_s$, then $B = A[s^{-1}]$. When B isn't a localization of A , the exact relationship between A and B remains obscure.

We extend the notation introduced for affine open sets to all open sets, denoting the algebra of regular functions on any open set U by $\mathcal{O}_X(U)$.

6.1.2. Corollary. *Let X be a variety. By defining $\mathcal{O}_X(U)$ to be the algebra of regular functions on an open subset U , the structure sheaf \mathcal{O}_X on X extends to a functor*

extendO

$$(\text{opens})^\circ \xrightarrow{\mathcal{O}_X} (\text{algebras}) \quad \square$$

The regular functions on U , the elements of $\mathcal{O}_X(U)$, are called *sections* of the structure sheaf \mathcal{O}_X on U , and the elements of $\mathcal{O}_X(X)$, the rational functions that are regular everywhere, are called *global sections*.

When $V \rightarrow U$ is a morphism in (*opens*), $\mathcal{O}_X(U)$ is contained in $\mathcal{O}_X(V)$. This gives us the homomorphism, an inclusion,

$$\mathcal{O}_X(U) \rightarrow \mathcal{O}_X(V)$$

that makes \mathcal{O}_X into a functor. Note that arrows are reversed by \mathcal{O}_X . If $V \rightarrow U$, then $\mathcal{O}_X(U) \rightarrow \mathcal{O}_X(V)$. A functor that reverses arrows is a *contravariant* functor. The superscript \circ in (6.1.1) and (6.1.2) is a customary notation to indicate that a functor is contravariant.

6.1.3. Proposition *The (extended) structure sheaf has the following sheaf property:*

extendO

- *Let Y be an open subset of X , and let $U^i = \text{Spec } A_i$ be affine open subsets that cover Y . Then*

$$\mathcal{O}_X(Y) = \bigcap \mathcal{O}_X(U^i) \quad (= \bigcap A_i)$$

This sheaf property is especially simple because regular functions are elements of the function field. It is more complicated for \mathcal{O} -modules, which will be defined in the next section.

By definition, if f is a regular function on X , there is a covering by affine open sets U^i such that f is regular on each of them, i.e., that f is in $\bigcap \mathcal{O}_X(U^i)$. Therefore the next lemma proves the proposition.

6.1.4. Lemma. *Let Y be an open subset of a variety X . The intersection $\bigcap \mathcal{O}_X(U^i)$ is the same for every affine open covering $\{U^i\}$ of Y .*

capsame

We prove the lemma first in the case of a covering of an affine open set by localizations.

sheaffor-
loc

6.1.5. Sublemma. *Let $U = \text{Spec } A$ be an affine variety, and let $\{U^i\}$ be a covering of U by localizations, say $U^i = \text{Spec } A_{s_i}$. Then $A = \bigcap A_{s_i}$, i.e., $\mathcal{O}(U) = \bigcap \mathcal{O}(U^i)$.*

proof. The fact that A is a subset of $\bigcap A_{s_i}$ is clear. We prove the opposite inclusion.

A finite subset of the set $\{U^i\}$ will cover U , so we may assume that the index set is finite. Let α be an element of $\bigcap A_{s_i}$. So $\alpha = s_i^{-r} a_i$, or $s_i^r \alpha = a_i$ for some a_i in A and some integer r , and we can use the same r for every i . Because $\{U^i\}$ covers U , the elements s_i generate the unit ideal in A , and so do their powers s_i^r . There are elements b_i in A such that $\sum b_i s_i^r = 1$. Then $\alpha = \sum b_i s_i^r \alpha = \sum b_i a_i$ is in A . \square

proof of Lemma 6.1.4. Say that Y is covered by affine open sets $\{U^i\}$ and also by affine open sets $\{V^j\}$. We cover the intersections $U^i \cap V^j$ by open sets $W^{ij\nu}$ that are localizations of U^i and also localizations of V^j . Fixing i and letting j and ν vary, the set $\{W^{ij\nu}\}_{j,\nu}$ will be a covering of U^i by localizations, and the sublemma shows that $\mathcal{O}(U^i) = \bigcap_{j,\nu} \mathcal{O}(W^{ij\nu})$. Then $\bigcap_i \mathcal{O}(U^i) = \bigcap_{i,j,\nu} \mathcal{O}(W^{ij\nu})$. Similarly, $\bigcap_j \mathcal{O}(V^j) = \bigcap_{i,j,\nu} \mathcal{O}(W^{ij\nu})$. \square

Section 6.2 O-Modules

module

An \mathcal{O}_X -module on a variety X associates a module to every affine open subset.

defO-
modtwo

6.2.1. Definition. An \mathcal{O} -module \mathcal{M} on a variety X is a (contravariant) functor

$$(\text{affines})^\circ \xrightarrow{\mathcal{M}} (\text{modules})$$

such that $\mathcal{M}(U)$ is an $\mathcal{O}(U)$ -module for every affine open set U , and such that, if s is a nonzero element of $\mathcal{O}(U)$, the module $\mathcal{M}(U_s)$ is the localization of $\mathcal{M}(U)$:

$$\mathcal{M}(U_s) = \mathcal{M}(U)_s$$

A *section* of an \mathcal{O} -module \mathcal{M} on an affine open set U is an element of $\mathcal{M}(U)$, and an element of $\mathcal{M}(X)$ is a *global section*. The $\mathcal{O}(U)$ -module $\mathcal{M}(U)$ is the *module of sections* of \mathcal{M} on U .

A *finite \mathcal{O} -module* \mathcal{M} is an \mathcal{O} -module such that $\mathcal{M}(U)$ is a finite $\mathcal{O}(U)$ -module for every affine open set U .

A *homomorphism* $\mathcal{M} \xrightarrow{\varphi} \mathcal{N}$ of \mathcal{O} -modules consists of homomorphisms of $\mathcal{O}(U)$ -modules

$$\mathcal{M}(U) \xrightarrow{\varphi(U)} \mathcal{N}(U)$$

for each affine open subset U of X such that, when s is a nonzero element of $\mathcal{O}(U)$, the homomorphism $\varphi(U_s)$ is the localization of $\varphi(U)$.

A sequence of homomorphisms

$$(6.2.2) \quad \mathcal{M} \rightarrow \mathcal{N} \rightarrow \mathcal{P}$$

exse-
qsheaves

of \mathcal{O} -modules on a variety X is *exact* if the sequence of sections $\mathcal{M}(U) \rightarrow \mathcal{N}(U) \rightarrow \mathcal{P}(U)$ is exact for every affine open subset U of X . \square

At first glance, this definition of an \mathcal{O} -module will seem too complicated for comfort. However, when a module has a natural definition, the data involved in the definition take care of themselves. This will become clear as we go along.

Note. When stating that $\mathcal{M}(U_s)$ is the localization of $\mathcal{M}(U)$, it would be more correct to say that $\mathcal{M}(U_s)$ and $\mathcal{M}(U)_s$ are canonically isomorphic. Let's not worry about this.

One example of an \mathcal{O} -module is the *free module* \mathcal{O}^k . The sections of the free module on an affine open set U are the elements of the free $\mathcal{O}(U)$ -module $\mathcal{O}(U)^k$. In particular, $\mathcal{O} = \mathcal{O}^1$ becomes an \mathcal{O} -module.

The *kernel*, *image*, and *cokernel* of a homomorphism $\mathcal{M} \xrightarrow{\varphi} \mathcal{N}$ are among the operations that can be made on \mathcal{O} -modules. The kernel \mathcal{K} of φ is the \mathcal{O} -module defined by $\mathcal{K}(U) = \ker(\mathcal{M}(U) \xrightarrow{\varphi(U)} \mathcal{N}(U))$ for every affine open set U , and the image and cokernel are defined analogously. The reason that we work with localizations is that many operations, including these, are compatible with localization.

Section 6.3 The Sheaf Property

In this section, we extend an \mathcal{O} -module \mathcal{M} on a variety X to a functor $(\text{opens})^\circ \xrightarrow{\widetilde{\mathcal{M}}} (\text{modules})$ on all open subsets of X , such that $\widetilde{\mathcal{M}}(Y)$ is an $\mathcal{O}(Y)$ -module for every open subset Y , and when U is an affine open set, $\widetilde{\mathcal{M}}(U) = \mathcal{M}(U)$.

nonaffine-
sections

The tilde $\widetilde{}$ is used for clarity here. When we have finished with the discussion, we will use the same notation for a functor on (affines) and for its extension to (opens) .

6.3.1. Terminology. Let $(\text{opens})^\circ \xrightarrow{\widetilde{\mathcal{M}}} (\text{modules})$ be a functor, and let U be an open subset, an element of $\widetilde{\mathcal{M}}(U)$ is a *section* of $\widetilde{\mathcal{M}}$ on U . If $V \xrightarrow{j} U$ is an inclusion of open subsets, the associated homomorphism $\widetilde{\mathcal{M}}(U) \rightarrow \widetilde{\mathcal{M}}(V)$ is the *restriction* from U to V . This restriction is defined because $\widetilde{\mathcal{M}}$ is a functor on (opens) , not only on (affines) .

restriction

The restriction to V of a section m may be denoted by $j^\circ m$. However, the operation of restriction occurs very often. Because of this, we usually abbreviate, using the same symbol m for a section and for its restriction. Also, if an open set V is contained in two open sets U and U' , and if m and m' are sections of $\widetilde{\mathcal{M}}$ on U and U' , respectively, we may say that m and m' are *equal on V* if their restrictions to V are equal. \square

6.3.2. Theorem. An \mathcal{O} -module \mathcal{M} extends uniquely to a functor

extend \mathcal{O} -
mod

$$(\text{opens})^\circ \xrightarrow{\widetilde{\mathcal{M}}} (\text{modules})$$

that has the sheaf property described below. Moreover, for every open set U , $\widetilde{\mathcal{M}}(U)$ is an $\mathcal{O}(U)$ -module, and for every inclusion $V \rightarrow U$ of nonempty open sets, the map $\widetilde{\mathcal{M}}(U) \rightarrow \widetilde{\mathcal{M}}(V)$ is compatible with scalar multiplication. By this we mean that, when $\widetilde{\mathcal{M}}(V)$ is made into an $\mathcal{O}(U)$ -module by restriction of scalars, it becomes a homomorphism of $\mathcal{O}(U)$ -modules (5.1.14).

Specifically, this means the following: Let m be a section of $\widetilde{\mathcal{M}}$ on U , let α be a regular function on U , an element of $\mathcal{O}(U)$, and let m' and α' denote the restrictions of m and α to V . The restriction of αm is $\alpha' m'$.

Though the proof of this theorem isn't especially difficult, it is lengthy because there are several things to check. In order not to break up the discussion, we have put the proof into Section 6.8 at the end of the chapter.

(6.3.3) the sheaf property

sheafprop

The sheaf property is the key requirement that determines the extension of an \mathcal{O} -module \mathcal{M} to a functor $\widetilde{\mathcal{M}}$ on (opens) .

Let Y be an open subset of X , and let $\{U^i\}$ be a covering of Y by affine open sets. The intersections $U^{ij} = U^i \cap U^j$ are also affine open sets, so $\mathcal{M}(U^i)$ and $\mathcal{M}(U^{ij})$ are defined. The sheaf property asserts that an element m of $\widetilde{\mathcal{M}}(Y)$ corresponds to a set of elements m_i in $\mathcal{M}(U^i)$ such that the restrictions of m_j and m_i to U^{ij} are equal.

If the affine open subsets U^i are indexed by $i = 1, \dots, n$, the sheaf property asserts that an element of $\widetilde{\mathcal{M}}(Y)$ is determined by a vector (m_1, \dots, m_n) with m_i in $\mathcal{M}(U^i)$, such that the restrictions of m_i and m_j to U^{ij} are equal. This means that $\widetilde{\mathcal{M}}(Y)$ is the kernel of the map

$$(6.3.4) \quad \prod_i \mathcal{M}(U^i) \xrightarrow{\beta} \prod_{i,j} \mathcal{M}(U^{ij})$$

sheafker

that sends the vector (m_1, \dots, m_n) to the $n \times n$ matrix (z_{ij}) , where z_{ij} is the difference $m_j - m_i$ of the restrictions of m_j and m_i to U^{ij} . The analogous description is true when the index set is infinite.

In short, the sheaf property tells us that sections of $\widetilde{\mathcal{M}}$ are determined locally: A section on an open set Y is determined by its restrictions to the open subsets U^i of any affine covering of Y .

Note. The morphisms $U^{ij} \rightarrow U^i$ needn't be localizations, and if not the restriction maps $\mathcal{M}(U^i) \rightarrow \mathcal{M}(U^{ij})$ aren't a part of the structure of an \mathcal{O} -module. We need a definition of the restriction map for an arbitrary

inclusion $V \rightarrow U$ of affine open subsets. This point will be taken care of by the proof of Theorem 6.3.2. (See Step 2 in Section 6.8.) We don't need to worry about it here. \square

We drop the tilde now, and denote by \mathcal{M} also the extension of an \mathcal{O} -module to all open sets. The sheaf property for \mathcal{M} is the statement that, when $\{U^i\}$ is an affine open covering of an open set U , the sequence

sheaf-
proptwo

$$(6.3.5) \quad 0 \rightarrow \mathcal{M}(U) \xrightarrow{\alpha} \prod_i \mathcal{M}(U^i) \xrightarrow{\beta} \prod_{i,j} \mathcal{M}(U^{ij})$$

is exact, where α is the product of the restriction maps, and β is the map described in (6.3.4). So $\mathcal{M}(U)$ is mapped isomorphically to the kernel of β . In particular, the composition $\beta\alpha$ is the zero map. Thus elements of $\mathcal{M}(U)$ correspond bijectively to vectors (m_1, \dots, m_n) , with m_i in $\mathcal{M}(U^i)$, such that the restrictions of m_i and m_j to $\mathcal{M}(U^{ij})$ are equal.

As with the structure sheaf, one should always work with the affine open sets. We may sometimes want to look at sections on other open sets, but most of the time, the non-affine open sets are just along for the ride.

The next corollary follows from Theorem 6.3.2.

injoncover

6.3.6. Corollary. *Let $\{U^i\}$ be an affine open covering of a variety X .*

(i) *An \mathcal{O} -module \mathcal{M} is zero if and only if $\mathcal{M}(U^i) = 0$ for every i .*

(ii) *A homomorphism $\mathcal{M} \xrightarrow{\varphi} \mathcal{N}$ of \mathcal{O} -modules is injective, surjective, or bijective if and only if the maps $\mathcal{M}(U^i) \xrightarrow{\varphi(U^i)} \mathcal{N}(U^i)$ are injective, surjective, or bijective, respectively, for every i .*

proof. (i) Let V be an open subset of X . We can cover the intersections $V \cap U^i$ by affine open sets $V^{i\nu}$ that are localizations of U^i , and these sets, taken together, cover V . If $\mathcal{M}(U^i) = 0$, then the localizations $\mathcal{M}(V^{i\nu})$ are zero too. The sheaf property shows that the map $\mathcal{M}(V) \rightarrow \prod \mathcal{M}(V^{i\nu})$ is injective, and therefore that $\mathcal{M}(V) = 0$.

(ii) This follows from (i) because a homomorphism φ is injective or surjective if and only if its kernel or its cokernel is zero. \square

omod

(6.3.7) families of open sets

It is convenient to have a more compact notation for the sheaf property. For this, one can use symbols to represent families of open sets. Say that \mathbb{U} and \mathbb{V} represent families of open sets $\{U^i\}$ and $\{V^\nu\}$, respectively. A *morphism* of families $\mathbb{V} \rightarrow \mathbb{U}$ consists of a morphism from each V^ν to one of the subsets U^i (an inclusion $V^\nu \rightarrow U^i$). Such a morphism will be given by a map $\nu \rightsquigarrow i_\nu$ of index sets, such that $V^\nu \subset U^{i_\nu}$.

There may be more than one morphism $\mathbb{V} \rightarrow \mathbb{U}$, because a subset V^ν may be contained in more than one of the subsets U^i . To define a morphism, one must make a choice among the subsets U^i that contain V^ν . For example, let $\mathbb{U} = \{U^i\}$ be a family of open sets, and let V be another open set. For each i such that $V \subset U^i$, there is a morphism $V \rightarrow \mathbb{U}$ that sends V to U^i . In the other direction, there is a unique morphism $\mathbb{U} \rightarrow V$ provided that $U^i \subset V$ for all i .

We extend a functor $(\text{opens})^\circ \xrightarrow{\mathcal{M}} (\text{modules})$ to families $\mathbb{U} = \{U^i\}$ by defining

section-
sonfamily

$$(6.3.8) \quad \mathcal{M}(\mathbb{U}) = \prod \mathcal{M}(U^i).$$

Then a morphism of families $\mathbb{V} \xrightarrow{f} \mathbb{U}$ defines a map $\mathcal{M}(\mathbb{V}) \xleftarrow{f^\circ} \mathcal{M}(\mathbb{U})$ in a way that is fairly obvious, though notation for it is clumsy. Say that f is given by a map $\nu \rightsquigarrow i_\nu$ of index sets, with $V^\nu \rightarrow U^{i_\nu}$. A section of \mathcal{M} on \mathbb{U} , an element of $\mathcal{M}(\mathbb{U})$, can be thought of as a vector (u_i) with $u_i \in \mathcal{M}(U^i)$, and a section of $\mathcal{M}(\mathbb{V})$ as a vector (v_ν) with $v_\nu \in \mathcal{M}(V^\nu)$. If v_ν denotes the restriction of u_{i_ν} to V^ν , the map f° sends $(u_{i_\nu}) \rightarrow (v_\nu)$.

We write the sheaf property in terms of families of open sets: Let $\mathbb{U}_0 = \{U^i\}$ be an affine open covering of an open set Y , and let \mathbb{U}_1 denote the family $\{U^{ij}\}$ of intersections: $U^{ij} = U^i \cap U^j$. The intersections are also affine, and there are two sets of inclusions

$$U^{ij} \subset U^i \quad \text{and} \quad U^{ij} \subset U^j$$

They define two morphisms of families $\mathbb{U}_1 \xrightarrow{d_0, d_1} \mathbb{U}_0$ of affine open sets: $U^{ij} \xrightarrow{d_0} U^j$ and $U^{ij} \xrightarrow{d_1} U^i$. We also have a morphism $\mathbb{U}_0 \rightarrow Y$, and the composed morphisms $\mathbb{U}_1 \xrightarrow{d_i} \mathbb{U}_0 \rightarrow Y$ are equal. These maps form what we call a *covering diagram*

$$(6.3.9) \quad Y \longleftarrow \mathbb{U}_0 \rightrightarrows \mathbb{U}_1 \quad \text{covdiagr}$$

When we apply a functor $(opens) \xrightarrow{\mathcal{M}} (modules)$ to this diagram, we obtain a sequence

$$(6.3.10) \quad 0 \rightarrow \mathcal{M}(Y) \xrightarrow{\alpha_{\mathbb{U}}} \mathcal{M}(\mathbb{U}_0) \xrightarrow{\beta_{\mathbb{U}}} \mathcal{M}(\mathbb{U}_1) \quad \text{defbeta}$$

where $\alpha_{\mathbb{U}}$ is the restriction map and $\beta_{\mathbb{U}}$ is the difference $\mathcal{M}(d_0) - \mathcal{M}(d_1)$ of the maps induced by the two morphisms $\mathbb{U}_1 \rightrightarrows \mathbb{U}_0$. The sheaf property for the covering \mathbb{U}_0 of Y (6.3.5) is the assertion that this sequence is exact, which means that $\alpha_{\mathbb{U}}$ is injective, and that its image is the kernel of $\beta_{\mathbb{U}}$.

6.3.11. Note. One can suppose that the open sets U^i that make a covering are distinct. However, the intersections won't be distinct, because $U^{ij} = U^{ji}$. Also, $U^{ii} = U^i$. These coincidences lead to redundancy in the statement (6.3.10) of the sheaf property. If the indices are $i = 1, \dots, k$, we only need to look at intersections U^{ij} with $i < j$. The product $\mathcal{M}(\mathbb{U}_1) = \prod_{i,j} \mathcal{M}(U^{ij})$ that appears in the sheaf property can be replaced by the product $\prod_{i < j} \mathcal{M}(U^{ij})$ with increasing pairs of indices. For instance, suppose that an open set Y is covered by two affine open sets U and V . The sheaf property is the exact sequence

$$0 \rightarrow \mathcal{M}(Y) \xrightarrow{\alpha} (\mathcal{M}(U) \times \mathcal{M}(V)) \xrightarrow{\beta} (\mathcal{M}(U \cap U) \times \mathcal{M}(U \cap V) \times \mathcal{M}(V \cap U) \times \mathcal{M}(V \cap V))$$

which is equivalent with the exact sequence

$$(6.3.12) \quad 0 \rightarrow \mathcal{M}(Y) \rightarrow (\mathcal{M}(U) \times \mathcal{M}(V)) \xrightarrow{+,-} \mathcal{M}(U \cap V) \quad \square \quad \text{twoopens}$$

6.3.13. Example.

Let A denote the polynomial ring $\mathbb{C}[x, y]$, and let V be the complement of a point p in affine space $X = \text{Spec } A$. We cover V by two localizations: $X_x = \text{Spec } A[x^{-1}]$ and $X_y = \text{Spec } A[y^{-1}]$. A regular function on V will be regular on X_x and on X_y , so it will be in the intersection of their coordinate algebras. The intersection $A[x^{-1}] \cap A[y^{-1}]$ is A . This tells us that the sections of the structure sheaf \mathcal{O}_X on V are the elements of A . They are the same as the sections on X . \square

We have been working with nonempty open sets. The next lemma takes care of the empty set.

6.3.14. Lemma. *The only section of an \mathcal{O} -module \mathcal{M} on the empty set is the zero section: $\mathcal{M}(\emptyset) = \{0\}$. In particular, $\mathcal{O}(\emptyset)$ is the zero ring.* emptyset

proof. This follows from the sheaf property. The empty set is covered by the empty covering, the covering indexed by the empty set. Therefore $\mathcal{M}(\emptyset)$ is contained in an empty product. We want both the empty product and $\mathcal{M}(\emptyset)$ to be modules, and we have no choice but to set them equal to $\{0\}$.

If you find this reasoning pedantic, you can take $\mathcal{M}(\emptyset) = \{0\}$ as an axiom. \square

(6.3.15) Interlude: a useful diagram

adiagram

We consider a (commutative) diagram of abelian groups of the form

$$\begin{array}{ccccccc} 0 & \longrightarrow & A & \xrightarrow{f} & B & \xrightarrow{g} & C \\ & & a \downarrow & & b \downarrow & & c \downarrow \\ 0 & \longrightarrow & A' & \xrightarrow{f'} & B' & \xrightarrow{g'} & C \end{array}$$

toprow

6.3.16. Lemma. (i) Suppose that the rows of the diagram are exact. If b and c are bijective, so is a .
(ii) Suppose that the bottom row of the diagram is exact. If a is bijective and b and c are injective, the top row is exact.

It is customary to leave the proofs of such statements to the reader. But since this sort of reasoning may be new, we'll give the proof of part **(ii)**. Here a, b, c and f' are injective, so f is injective and $gf = 0$. It remains to show that $\ker g = \text{im } f$. Let x be an element of $\ker g$, so that $gx = 0$, and let $x' = bx$. Then $g'x' = g'bx = c'gx = 0$. Since the bottom row is exact, $x' = f'y'$ for some unique element y' of A' . Since a is bijective, $y' = ay$ for some element y of A . Then $bfy = f'ay = f'y' = x' = bx$. Since b is injective, $fy = x$. \square

coherence

(6.3.17) the coherence property

In addition to the sheaf property, an \mathcal{O} -module on a variety X has a property called *coherence*.

cohprop

6.3.18. Proposition. (the coherence property) Let Y be an open subset of a variety X , let s be a nonzero regular function on Y , and let \mathcal{M} be an \mathcal{O}_X -module. Then $\mathcal{M}(Y_s)$ is the localization $\mathcal{M}(Y)_s$ of $\mathcal{M}(Y)$. In particular, $\mathcal{O}_X(U_s)$ is the localization $\mathcal{O}_X(U)_s$ of $\mathcal{O}(U)$.

Compatibility with localization is a requirement for an \mathcal{O} -module when Y is affine. The coherence property is the extension to all open subsets.

proof of Proposition 6.3.18. Let $\mathbb{U}_0 = \{U^i\}$ be a family of affine open sets that covers an open set Y . The intersections U^{ij} will be affine open sets too. We inspect the covering diagram $Y \leftarrow \mathbb{U}_0 \rightrightarrows \mathbb{U}_1$. If s is a nonzero regular function on Y , the localization of this diagram forms a covering diagram $Y_s \leftarrow \mathbb{U}_{0,s} \rightrightarrows \mathbb{U}_{1,s}$, in which $\mathbb{U}_{0,s} = \{U_s^i\}$ is an affine covering of Y_s . Therefore $\mathcal{M}(\mathbb{U}_0)_s \approx \mathcal{M}(\mathbb{U}_{0,s})$. The sheaf property for the two covering diagrams gives us exact sequences

$$0 \rightarrow \mathcal{M}(Y) \rightarrow \mathcal{M}(\mathbb{U}_0) \rightarrow \mathcal{M}(\mathbb{U}_1) \quad \text{and} \quad 0 \rightarrow \mathcal{M}(Y_s) \rightarrow \mathcal{M}(\mathbb{U}_{0,s}) \rightarrow \mathcal{M}(\mathbb{U}_{1,s})$$

The sequence on the left maps to the one on the right, and since s is invertible in sequence on the right, the localization of the left sequence maps to it:

$$\begin{array}{ccccccc} 0 & \longrightarrow & \mathcal{M}(Y)_s & \longrightarrow & \mathcal{M}(\mathbb{U}_0)_s & \longrightarrow & \mathcal{M}(\mathbb{U}_1)_s \\ & & a \downarrow & & b \downarrow & & c \downarrow \\ 0 & \longrightarrow & \mathcal{M}(Y_s) & \longrightarrow & \mathcal{M}(\mathbb{U}_{0,s}) & \longrightarrow & \mathcal{M}(\mathbb{U}_{1,s}) \end{array}$$

In this diagram, the bottom row is exact, and since localization is an exact operation, the top row is exact too. Since \mathbb{U}_0 and \mathbb{U}_1 are families of affine open sets, the vertical arrows b and c are bijections. Therefore a is a bijection (6.3.16)(i). This is the coherence property. \square

6.4 Some O-Modules

modules
examples

6.4.1. \mathcal{O} -modules on an affine variety

When $X = \text{Spec } A$ is an affine variety, \mathcal{O} -modules correspond bijectively to ordinary A -modules. This will be proved below, in Proposition 6.4.18.

sheafon-
point

6.4.2. modules on a point

Let's denote a point, the affine variety $\text{Spec } \mathbb{C}$, by p . The point has only one nonempty open set: the whole space p , and $\mathcal{O}_p(p) = \mathbb{C}$. Let \mathcal{M} be an \mathcal{O}_p -module. The space of global sections $\mathcal{M}(p)$ is an $\mathcal{O}_p(p)$ -module, a complex vector space. To define \mathcal{M} , that vector space can be assigned arbitrarily. One may say that a module on the point is a complex vector space.

refldmod

6.4.3. the residue field module κ_p .

Let p be a point of a variety X . A residue field module κ_p is defined as follows: If U is an affine open subset of X that contains p , then $\mathcal{O}(U)$ has a residue field $k(p)$ at p , and $\kappa_p(U) = k(p)$. If U doesn't contain p , then $\kappa_p(U) = 0$.

For example, if p is the point at infinity of $X = \mathbb{P}^1$, then $\kappa_p(\mathbb{U}^0) = 0$ and $\kappa_p(\mathbb{U}^1) = \mathbb{C}$.

6.4.4. torsion modules.

An \mathcal{O} -module \mathcal{M} is a *torsion module* if $\mathcal{M}(U)$ is a torsion $\mathcal{O}(U)$ -module for every affine open set U (see (2.6.5)).

6.4.5. ideals.

An ideal \mathcal{I} of the structure sheaf is an \mathcal{O} -submodule of \mathcal{O} .

If Y is a closed subvariety of a variety X , the *ideal of Y* is the ideal \mathcal{I} whose sections on an affine open subset U of X are the rational functions on X that are regular on U and that vanish on $Y \cap U$.

If \mathcal{I} is the ideal of a closed variety Y , then $V_X(\mathcal{I}) = Y$.

Let p be a point of a variety X . The *maximal ideal at p* , which we denote by \mathfrak{m}_p , is the ideal of the point. If an affine open subset U contains p , its coordinate algebra $\mathcal{O}(U)$ will have a maximal ideal consisting of the elements that vanish at p . That maximal ideal is the module of sections $\mathfrak{m}_p(U)$ on U . If U doesn't contain p , then $\mathfrak{m}_p(U) = \mathcal{O}(U)$.

We extend the notation $V_X(\mathcal{I})$ to ideals \mathcal{I} in the structure sheaf. A point p is in the subset $V_X(\mathcal{I})$ if, whenever U is an affine open subset of X that contains p , all elements of $\mathcal{I}(U)$ vanish at p . When \mathcal{I} is the ideal of a closed variety Y , $V_X(\mathcal{I}) = Y$.

6.4.6. examples of homomorphisms

(i) Let κ_p be the residue field module at a point p of X . There is a homomorphism of \mathcal{O} -modules $\mathcal{O} \rightarrow \kappa_p$ whose kernel is the maximal ideal \mathfrak{m}_p at p .

(ii) Homomorphisms $\mathcal{O}^n \rightarrow \mathcal{O}^m$ of free \mathcal{O} -modules correspond to $m \times n$ -matrices of global sections of \mathcal{O} .

(iii) If f is a global section of \mathcal{O} , scalar multiplication by f defines a homomorphism $\mathcal{M} \xrightarrow{f} \mathcal{M}$.

(iv) Let \mathcal{M} be an \mathcal{O} -module. The \mathcal{O} -module homomorphisms $\mathcal{O} \xrightarrow{\varphi} \mathcal{M}$ correspond bijectively to global sections of \mathcal{M} .

This is analogous to the fact that, when M is a module over a ring A , homomorphisms $A \rightarrow M$ correspond to elements of M . To be explicit: If m is a global section of \mathcal{M} , the homomorphism $\mathcal{O}(U) \xrightarrow{\varphi} \mathcal{M}(U)$ is multiplication by the restriction of m to U . It sends a regular function f on U to fm .

defker

6.4.7. kernel

As we have remarked, many operations that one makes on modules over a ring are compatible with localization, and therefore can be made on \mathcal{O} -modules. However, one always needs to use the sheaf property to determine sections on non-affine open sets. Most often, the operations don't determine the sections over non-affine open sets. One important operation that does extend to all open sets is the kernel of a homomorphism.

6.4.8. Proposition. *Let X be a variety, and let \mathcal{K} be the kernel of a homomorphism of \mathcal{O} -modules $\mathcal{M} \rightarrow \mathcal{N}$, so that there is an exact sequence $0 \rightarrow \mathcal{K} \rightarrow \mathcal{M} \rightarrow \mathcal{N}$. For every open subset Y of X , the sequence of sections*

$$(6.4.9) \quad 0 \rightarrow \mathcal{K}(Y) \rightarrow \mathcal{M}(Y) \rightarrow \mathcal{N}(Y)$$

is exact.

proof. We choose a covering diagram $Y \leftarrow \mathbb{U}_0 \rightrightarrows \mathbb{U}_1$, and inspect the diagram

$$\begin{array}{ccccccc} 0 & \longrightarrow & \mathcal{K}(\mathbb{U}_0) & \longrightarrow & \mathcal{M}(\mathbb{U}_0) & \longrightarrow & \mathcal{N}(\mathbb{U}_0) \\ & & \downarrow & & \downarrow & & \downarrow \\ 0 & \longrightarrow & \mathcal{K}(\mathbb{U}_1) & \longrightarrow & \mathcal{M}(\mathbb{U}_1) & \longrightarrow & \mathcal{N}(\mathbb{U}_1) \end{array}$$

where the vertical maps are the maps $\beta_{\mathbb{U}}$ described in (6.3.10). The rows are exact because \mathbb{U}_0 and \mathbb{U}_1 are families of affines, and the sheaf property asserts that the kernels of the vertical maps form the sequence (6.4.9). That sequence is exact because taking kernels is a left exact operation (5.1.2). \square

The section functor isn't right exact. When $\mathcal{M} \rightarrow \mathcal{N}$ is a surjective homomorphism of \mathcal{O} -modules and Y is a non-affine open set, the map $\mathcal{M}(Y) \rightarrow \mathcal{N}(Y)$ may fail to be surjective. There is an example below. Cohomology, which will be discussed in the next chapter, is a substitute for right exactness.

kerthm

leftexact-section

lexsect

coverpone

6.4.10. modules on the projective line

The projective line \mathbb{P}^1 is covered by the standard open sets \mathbb{U}^0 and \mathbb{U}^1 , and the intersection $\mathbb{U}^{01} = \mathbb{U}^0 \cap \mathbb{U}^1$ is a localization of \mathbb{U}^0 and of \mathbb{U}^1 . The coordinate algebras of these affine open sets are $\mathcal{O}(\mathbb{U}^0) = A_0 = \mathbb{C}[u]$, $\mathcal{O}(\mathbb{U}^1) = A_1 = \mathbb{C}[v]$, with $v = u^{-1}$, and $\mathcal{O}(\mathbb{U}^{01}) = A_{01} = \mathbb{C}[u, u^{-1}]$. The algebra A_{01} is the Laurent polynomial ring whose elements are (finite) combinations of powers of u , negative powers included. The form (6.3.12) of the sheaf property asserts that a global section of \mathcal{O} is determined by polynomials $f(u)$ in A_0 and $g(v)$ in A_1 such that $f(u) = g(u^{-1})$ in A_{01} . So the only such polynomials f and g are the constants. The only rational functions that are regular everywhere on \mathbb{P}^1 are the constants. I think we knew this.

If \mathcal{M} is an \mathcal{O} -module, $\mathcal{M}(\mathbb{U}^0) = M_0$ and $\mathcal{M}(\mathbb{U}^1) = M_1$ will be modules over the algebras A_0 and A_1 , and the A_{01} -module $\mathcal{M}(\mathbb{U}^{01}) = M_{01}$ can be obtained by localizing M_0 and also by localizing M_1 : $M_0[u^{-1}] \approx M_{01} \approx M_1[v^{-1}]$. As (6.3.12) tells us, a global section of \mathcal{M} is determined by a pair of elements m_1, m_2 in M_1, M_2 , respectively, that become equal in the common localization M_{01} . In fact, these data determine the module \mathcal{M} .

modon-
pone

6.4.11. Lemma. *With notation as above, let M_0, M_1 , and M_{01} be modules over the algebras A_0, A_1 , and A_{01} , respectively, and let $M_0[u^{-1}] \xrightarrow{\varphi_0} M_{01}$ and $M_1[v^{-1}] \xrightarrow{\varphi_1} M_{01}$ be A_{01} -isomorphisms. There is an \mathcal{O}_X -module \mathcal{M} , unique up to isomorphism, that gives this data: $\mathcal{M}(\mathbb{U}^0)$ and $\mathcal{M}(\mathbb{U}^1)$ are isomorphic to M_0 and M_1 , and the diagram below commutes.*

$$\begin{array}{ccccc} \mathcal{M}(\mathbb{U}^0) & \longrightarrow & \mathcal{M}(\mathbb{U}^{01}) & \longleftarrow & \mathcal{M}(\mathbb{U}^1) \\ \downarrow & & \downarrow & & \downarrow \\ M_0 & \xrightarrow{\varphi_0} & M_{01} & \xleftarrow{\varphi_1} & M_1 \end{array}$$

The proof is at the end of this section.

Suppose that M_0 and M_1 are free modules of rank r over A_0 and A_1 ,. Then M_{01} will be a free A_{01} -module of rank r . A basis \mathbf{B}_0 of the free A_0 -module M_0 will also be a basis of the A_{01} -module M_{01} , and a basis \mathbf{B}_1 of M_1 will be a basis of M_{01} . When regarded as bases of M_{01} , \mathbf{B}_0 and \mathbf{B}_1 will be related by an invertible $r \times r$ A_{01} -matrix P , and that matrix determines \mathcal{M} up to isomorphism. When $r = 1$, P will be an invertible 1×1 matrix in the Laurent polynomial ring A_{01} – a unit of that ring. The units in A_{01} are scalar multiples of powers of u . Since the scalar can be absorbed into one of the bases, an \mathcal{O} -module of rank 1 is determined, up to isomorphism, by a power of u . It is one of the twisting modules that will be described in Section 6.7.

The Birkhoff-Grothendieck Theorem, which will be proved in Chapter 8, describes the \mathcal{O} -modules on the projective line whose sections on \mathbb{U}^0 and on \mathbb{U}^1 are free. They are direct sums of free \mathcal{O} -modules of rank one. This means that by changing the bases \mathbf{B}_0 and \mathbf{B}_1 , one can diagonalize the matrix P . Such changes of basis will be given by an invertible A_0 -matrix Q_0 and an invertible A_1 -matrix Q_1 , respectively. In down-to-Earth terms, the Birkhoff-Grothendieck Theorem asserts that, for any invertible A_{01} -matrix P , there exist two matrices: an invertible A_0 -matrix Q_0 and an invertible A_1 -matrix Q_1 , such that $Q_0^{-1}PQ_1$ is diagonal. This can be proved by matrix operations. \square

tensprod-
module

6.4.12. tensor products

AS Corollary 5.1.10 asserts, tensor products are compatible with localization. If M and N are modules over a domain A and s is a nonzero element of A , the canonical map $(M \otimes_A N)_s \rightarrow M_s \otimes_{A_s} N_s$ is an isomorphism. Therefore the tensor product $\mathcal{M} \otimes_{\mathcal{O}} \mathcal{N}$ of \mathcal{O} -modules \mathcal{M} and \mathcal{N} is defined. On an affine open set U , $[\mathcal{M} \otimes_{\mathcal{O}} \mathcal{N}]$ is the tensor product $\mathcal{M}(U) \otimes_{\mathcal{O}(U)} \mathcal{N}(U)$.

Let \mathcal{M} and \mathcal{N} be \mathcal{O} -modules, let $\mathcal{M} \otimes_{\mathcal{O}} \mathcal{N}$ be the tensor product module, and let V be an arbitrary open subset of X . There is a canonical map

$$(6.4.13) \quad \mathcal{M}(V) \otimes_{\mathcal{O}(V)} \mathcal{N}(V) \rightarrow [\mathcal{M} \otimes_{\mathcal{O}} \mathcal{N}](V)$$

When V is affine, this map exists and is an equality, by definition of the tensor product module. For arbitrary V , we cover by a family \mathbb{U}_0 of affine open sets. The family \mathbb{U}_1 of intersections also consists of affine open sets. We form a diagram

$$\begin{array}{ccccccc} \mathcal{M}(V) \otimes_{\mathcal{O}(V)} \mathcal{N}(V) & \longrightarrow & \mathcal{M}(\mathbb{U}_0) \otimes_{\mathcal{O}(\mathbb{U}_0)} \mathcal{N}(\mathbb{U}_0) & \longrightarrow & \mathcal{M}(\mathbb{U}_1) \otimes_{\mathcal{O}(\mathbb{U}_1)} \mathcal{N}(\mathbb{U}_1) \\ \downarrow a & & \downarrow b & & \downarrow c \\ 0 & \longrightarrow & [\mathcal{M} \otimes_{\mathcal{O}} \mathcal{N}](V) & \longrightarrow & [\mathcal{M} \otimes_{\mathcal{O}} \mathcal{N}](\mathbb{U}_0) & \longrightarrow & [\mathcal{M} \otimes_{\mathcal{O}} \mathcal{N}](\mathbb{U}_1) \end{array}$$

ten-
sprodmap

The composition of the two arrows in the top row is zero, the bottom row is exact, and the vertical maps b and c are isomorphic. The canonical map a is induced by the diagram. It is bijective when V is affine, but when V isn't affine, it needn't be either injective or surjective.

6.4.14. Examples. (i) Let p and q be distinct points of the projective line X , and let κ_p and κ_q be the residue field modules on X . Then $\kappa_p(X) = \kappa_q(X) = \mathbb{C}$, so $\kappa_p(X) \otimes_{\mathcal{O}(X)} \kappa_q(X) \approx \mathbb{C} \otimes_{\mathbb{C}} \mathbb{C} = \mathbb{C}$. But $\kappa_p \otimes_{\mathcal{O}} \kappa_q = 0$. The canonical map (6.4.13) is the zero map. It isn't injective.

residue-
fieldmod-
ule

Since $U^0 = X - p$ and $U^1 = X - q$ cover X , the sheaf property shows that the canonical map (6.4.13) is the zero map.

(ii) Let p a point of a variety X , and let \mathfrak{m}_p and κ_p be the maximal ideal and residue field modules at p . There is an exact sequence of \mathcal{O} -modules

$$(6.4.15) \quad 0 \rightarrow \mathfrak{m}_p \rightarrow \mathcal{O} \xrightarrow{\pi_p} \kappa_p \rightarrow 0$$

ideal-
sheafatp

In this case, the sequence of global sections is exact.

(iii) Let p_0 and p_1 be the points $(1, 0)$ and $(0, 1)$ of the projective line \mathbb{P}^1 . We form a homomorphism

$$\mathfrak{m}_{p_0} \times \mathfrak{m}_{p_1} \xrightarrow{\varphi} \mathcal{O}$$

φ being the map $(a, b) \mapsto b - a$. On the open set \mathbb{U}^0 , $\mathfrak{m}_{p_1} \rightarrow \mathcal{O}$ is bijective and therefore surjective. Similarly, $\mathfrak{m}_{p_0} \rightarrow \mathcal{O}$ is surjective on \mathbb{U}^1 . Therefore φ is surjective. The only global sections of \mathfrak{m}_{p_0} , \mathfrak{m}_{p_1} , and $\mathfrak{m}_{p_0} \times \mathfrak{m}_{p_1}$ are the zero sections, while \mathcal{O} has the nonzero global section 1. The map φ isn't surjective on global sections. \square

6.4.16. the function field module

ffldmod

Let F be the function field of a variety X . The *function field module* \mathcal{F} is defined as follows: Its module of sections on any nonempty open set U is the field F . This is an \mathcal{O} -module. It is called a *constant \mathcal{O} -module* because the modules of sections $\mathcal{F}(U)$ are the same for every nonempty U . It isn't a finite module unless X is a point.

Tensoring with the function field module: Let \mathcal{M} be an \mathcal{O} -module on a variety X , and let \mathcal{F} be the function field module. Then $\mathcal{M} \otimes_{\mathcal{O}} \mathcal{F}$ is a constant \mathcal{O} -module whose sections on any affine open set U form an F -vector space. But if \mathcal{M} is a torsion module, $\mathcal{M} \otimes_{\mathcal{O}} \mathcal{F}$ will be zero.

(6.4.17) \mathcal{O} -modules on affine varieties

modaff

6.4.18. Proposition. Let $X = \text{Spec } A$ be an affine variety. Sending an \mathcal{O} -module \mathcal{M} to the A -module $\mathcal{M}(X)$ of its global sections defines a bijective correspondence between \mathcal{O} -modules and A -modules.

moduleon-
affines

proof. We must invert the functor $\mathcal{O} - (\text{modules}) \rightarrow A - (\text{modules})$ that sends \mathcal{M} to $\mathcal{M}(X)$. Given an A -module M , the corresponding \mathcal{O} -module \mathcal{M} is defined as follows: Let $U = \text{Spec } B$ be an affine open subset of X . The inclusion $U \subset X$ corresponds to an algebra homomorphism $A \rightarrow B$. We define $\mathcal{M}(U)$ to be the B -module $B \otimes_A M$. If s is a nonzero element of B , then $B_s \otimes_A M$ is canonically isomorphic to the localization $(B \otimes_A M)_s$ of $B \otimes_A M$. Therefore \mathcal{M} is an \mathcal{O} -module, and $\mathcal{M}(X) = M$.

Conversely, let \mathcal{M} be an \mathcal{O} -module such that $\mathcal{M}(X) = M$. Then, with notation as above, the map $M = \mathcal{M}(X) \rightarrow \mathcal{M}(U)$ is compatible with the map $A \rightarrow B$ (6.3.2). It induces a homomorphism of B -modules $M \otimes_A B \rightarrow \mathcal{M}(U)$ (5.1.14.6.3.2). When U is a localization X_s of X , so that $B = A_s$, both $M \otimes_A A_s$ and $\mathcal{M}(X_s)$ are localizations of M , so they are isomorphic. Therefore the module \mathcal{M} is unique up to isomorphism. \square

6.4.19. Example.

delete-
point

This example shows that, when an open subset isn't affine, defining $\mathcal{M}(V) = B \otimes_A M$, as in Proposition 6.4.18, may be wrong. Let X be the affine plane $\text{Spec } A$, $A = \mathbb{C}[x, y]$, let V be the complement of the origin in X , and let M be the A -module A/yA . This module can be identified with $\mathbb{C}[x]$, which becomes an A -module when scalar multiplication by y is defined to be zero. Here $\mathcal{O}(V) = \mathcal{O}(X) = A$ (6.3.13). If we followed the method used for affine open sets, we would set $\mathcal{M}(V) = A \otimes_A M = \mathbb{C}[x]$.

To identify $\mathcal{M}(V)$ correctly, we cover V by the two affine open sets $V_x = \text{Spec } A[x^{-1}]$ and $V_y = \text{Spec } A[y^{-1}]$. Then $\mathcal{M}(V_x) = M[x^{-1}]$ while $\mathcal{M}(V_y) = 0$. The sheaf property of \mathcal{M} shows that $\mathcal{M}(V) \approx \mathcal{M}(V_x) = M[x^{-1}] = \mathbb{C}[x, x^{-1}]$. \square

omodlim **(6.4.20) limits of \mathcal{O} -modules**

limits **6.4.21.** A directed set M_\bullet of modules over a ring R is a sequence of homomorphisms of R -modules $M_0 \rightarrow M_1 \rightarrow M_2 \rightarrow \dots$. Its limit $\varinjlim M_\bullet$ is the R -module whose elements are equivalence classes on the union $\bigcup M_k$, the equivalence relation being that elements m in M_i and m' in M_j are equivalent if they have the same image in M_n when n is sufficiently large. An element of $\varinjlim M_\bullet$ will be represented by an element of M_i for some i .

limexam- **6.4.22. Example.** Let $R = \mathbb{C}[x]$ and let \mathfrak{m} be the maximal ideal xR . Repeated multiplication by x defines a directed set

$$R \xrightarrow{x} R \xrightarrow{x} R \xrightarrow{x} R \dots$$

whose limit is isomorphic to the Laurent polynomial ring $R[x^{-1}] = \mathbb{C}[x, x^{-1}]$. Proving this is an exercise. \square

A directed set of \mathcal{O} -modules on a variety X is a sequence $\mathcal{M}_\bullet = \{\mathcal{M}_0 \rightarrow \mathcal{M}_1 \rightarrow \mathcal{M}_2 \rightarrow \dots\}$ of homomorphisms of \mathcal{O} -modules. So, for every affine open set U , the $\mathcal{O}(U)$ -modules $\mathcal{M}_n(U)$ form a directed set, as defined in (6.4.21). The direct limit $\varinjlim \mathcal{M}_\bullet$ is defined simply, by taking the limit for each affine open set: $[\varinjlim \mathcal{M}_\bullet](U) = \varinjlim [\mathcal{M}_\bullet(U)]$. This limit operation is compatible with localization, so $\varinjlim \mathcal{M}_\bullet$ is an \mathcal{O} -module. In fact, the equality $[\varinjlim \mathcal{M}_\bullet](U) = \varinjlim [\mathcal{M}_\bullet(U)]$ will be true for every open set.

jstarlimit **6.4.23. Lemma. (i)** The limit operation is exact. If $\mathcal{M}_\bullet \rightarrow \mathcal{N}_\bullet \rightarrow \mathcal{P}_\bullet$ is an exact sequence of directed sets of \mathcal{O} -modules, the limits form an exact sequence.

(ii) Tensor products are compatible with limits: If \mathcal{N}_\bullet is a directed set of \mathcal{O} -modules and \mathcal{M} is another \mathcal{O} -module, then $\varinjlim [\mathcal{M} \otimes_{\mathcal{O}} \mathcal{N}_\bullet] \approx \mathcal{M} \otimes_{\mathcal{O}} [\varinjlim \mathcal{N}_\bullet]$.

proof of Lemma 6.4.11. With notation as in the proposition, we suppose given the modules M_0, M_1 and isomorphisms $M_0[u^{-1}] \rightarrow M_1[v^{-1}]$, and we are to show that this data comes from an \mathcal{O} -module \mathcal{M} . Proposition 6.4.18 shows that M_i defines modules \mathcal{M}_i on \mathbb{U}^i whose restrictions to \mathbb{U}^{01} are isomorphic. Let's denote all of these modules by \mathcal{M} . Then \mathcal{M} is defined on open sets that are contained in \mathbb{U}^0 or in \mathbb{U}^1 .

Let V be an arbitrary open set V , and let $V^i = V \cap \mathbb{U}^i$ we define $\mathcal{M}(V)$ to be the kernel of the map $\mathcal{M}(V^0 \times \mathcal{M}(V^1)) \rightarrow \mathcal{M}(V^{01})$. It is clear that with this definition, \mathcal{M} is a functor. We must verify the sheaf property, and the notation can get confusing. We suppose given an open covering $\{V^\nu\}$ of V , and to avoid confusion with V^0 and V^1 , we write $\{V^\nu\} = \mathbb{W}_0$, and $\{V^\nu \cap V^\mu\} = \mathbb{W}_1$, so that the corresponding covering diagram is $V \leftarrow \mathbb{W}_0 \rightrightarrows \mathbb{W}_1$. We form a diagram

$$\begin{array}{ccccccc}
 & & 0 & & 0 & & 0 \\
 & & \downarrow & & \downarrow & & \downarrow \\
 0 & \longrightarrow & \mathcal{M}(V) & \longrightarrow & \mathcal{M}(\mathbb{W}_0) & \longrightarrow & \mathcal{M}(\mathbb{W}_1) \\
 & & \downarrow & & \downarrow & & \downarrow \\
 0 & \longrightarrow & \mathcal{M}(V^0) \times \mathcal{M}(V^1) & \longrightarrow & * & \longrightarrow & * \\
 & & \downarrow & & \downarrow & & \downarrow \\
 0 & \longrightarrow & \mathcal{M}(V^{01}) & \longrightarrow & * & \longrightarrow & *
 \end{array}$$

in which the first asterisk in the second row stands for $\mathcal{M}(\mathbb{W}_0 \cap \mathbb{U}^0) \times \mathcal{M}(\mathbb{W}_0 \cap \mathbb{U}^1)$, etc. The columns are exact by our definition of \mathcal{M} , and the second and third rows are exact because the open sets involved are contained in \mathbb{U}^0 or \mathbb{U}^1 . Since kernel is a left exact operation, the top row is exact too. This is the sheaf property. \square

6.5 Direct Image

Let $Y \xrightarrow{f} X$ be a morphism of varieties, and let \mathcal{N} be an \mathcal{O}_Y -module. The *direct image* $f_*\mathcal{N}$ is an \mathcal{O}_X -module that is defined as follows: The sections of $f_*\mathcal{N}$ on an affine open subset U of X are the sections of \mathcal{N} on the inverse image $V = f^{-1}U$ in Y . For example, the direct image $f_*\mathcal{O}_Y$ of the structure sheaf \mathcal{O}_Y is the functor

$$\mathcal{O}_Y\text{-modules} \xrightarrow{f_*} \mathcal{O}_X\text{-modules}$$

defined by $[f_*\mathcal{O}_Y](U) = \mathcal{O}_Y(f^{-1}U)$.

Note. A morphism is a continuous map, so when U is open in X , its inverse image $f^{-1}(U)$ will be open in Y . However, if U is an affine open subset of X , $f^{-1}(U)$ needn't be affine. Since \mathcal{O} -modules are defined in terms of affine open subsets, we will have to be careful.

The direct image generalizes restriction of scalars in modules over rings. Recall (5.1.12) that, if $A \xrightarrow{\varphi} B$ is an algebra homomorphism and N is a B -module, one can *restrict scalars* to make N into an A -module. Scalar multiplication by an element a of A on the restricted module N is defined to be scalar multiplication by its image $\varphi(a)$. For clarity, we may denote the given B -module by N_B and the A -module obtained by restriction of scalars by N_A . As additive groups, N_b and N_a are equal.

Let $X = \text{Spec } A$ and $Y = \text{Spec } B$, and let $Y \xrightarrow{f} X$ be the morphism of affine varieties defined by an algebra homomorphism $A \xrightarrow{\varphi} B$. An \mathcal{O}_Y -module \mathcal{N} is determined by a B -module $N = N_B$. The direct image $f_*\mathcal{N}$ is the \mathcal{O}_X -module determined by the A -module N_A .

6.5.1. Lemma. *Let $Y \xrightarrow{f} X$ be a morphism of varieties. The direct image $f_*\mathcal{N}$ of an \mathcal{O}_Y -module \mathcal{N} is an \mathcal{O}_X -module. Moreover, for all open subsets U of X , not only for affine open subsets,*

$$[f_*\mathcal{N}](U) = \mathcal{N}(f^{-1}U)$$

proof. Let $U' \rightarrow U$ be an inclusion of affine open subsets of X , and let $V = f^{-1}U$ and $V' = f^{-1}U'$. These inverse images are open subsets of Y , not necessarily affine open subsets. Nevertheless, the inclusion $V' \rightarrow V$ gives us a homomorphism $\mathcal{N}(V) \rightarrow \mathcal{N}(V')$, and therefore a homomorphism $f_*\mathcal{N}(U) \rightarrow f_*\mathcal{N}(U')$. So $f_*\mathcal{N}$ is a functor. Its \mathcal{O}_X -module structure is explained as follows: Composition with f defines a homomorphism $\mathcal{O}_X(U) \rightarrow \mathcal{O}_Y(V)$, and $\mathcal{N}(V)$ is an $\mathcal{O}_Y(V)$ -module. Restriction of scalars to $\mathcal{O}_X(U)$ makes $[f_*\mathcal{N}](U) = \mathcal{N}(V)$ into an $\mathcal{O}_X(U)$ -module.

To show that $f_*\mathcal{N}$ is an \mathcal{O}_X -module, we must show that if s is a nonzero element of $\mathcal{O}_X(U)$, then $[f_*\mathcal{N}](U_s)$ is obtained by localizing $[f_*\mathcal{N}](U)$. Let s' be the image of s in $\mathcal{O}_Y(V)$. Scalar multiplication by s on $[f_*\mathcal{N}](U)$ is given by restriction of scalars, so it is the same as scalar multiplication by s' on $\mathcal{N}(V)$. If $s' \neq 0$, the localization $V_{s'}$ is the inverse image of U_s . So $[f_*\mathcal{N}](U_s) = \mathcal{N}(V_{s'})$. The coherence property (6.3.17) tells us that $\mathcal{N}(V_{s'}) = \mathcal{N}(V)_{s'}$. Then $[f_*\mathcal{N}](U_s) = \mathcal{N}(V_{s'}) = \mathcal{N}(V)_{s'} = [[f_*\mathcal{N}](U)]_s$.

If $s' = 0$, then $\mathcal{N}(V)_{s'} = 0$. In this case, because scalar multiplication is defined by restricting scalars, s annihilates $[f_*\mathcal{N}](U)$, and therefore $[f_*\mathcal{N}](U)_s = 0$ too. \square

6.5.2. Lemma. *Direct images are compatible with limits: If \mathcal{M}_\bullet is a directed set of \mathcal{O} -modules, then*

$$\varinjlim (f_*\mathcal{M}_\bullet) \approx f_*(\varinjlim \mathcal{M}_\bullet).$$

(6.5.3) extension by zero

When $Y \xrightarrow{i} X$ is the inclusion of a **closed** subvariety into a variety X , and \mathcal{N} is an \mathcal{O}_Y -module, the direct image $i_*\mathcal{N}$ is also called the *extension by zero* of \mathcal{N} . If U is an open subset of X then, because i is an inclusion map, $i^{-1}U = U \cap Y$. Therefore

$$[i_*\mathcal{N}](U) = \mathcal{N}(U \cap Y)$$

The term “extension by zero” refers to the fact that, when an open set U of X doesn't meet Y , the intersection $U \cap Y$ is empty, and the module of sections of $[i_*\mathcal{N}](U)$ is zero. So $i_*\mathcal{N}$ is zero outside of the closed set Y .

directim-
age

fstarcoh

dirimlim

extbyzero

extfrom-
point

6.5.4. Examples.

(i) Let $p \xrightarrow{i} X$ be the inclusion of a point into a variety. When we view the residue field $k(p)$ as an \mathcal{O} -module on p , its extension by zero $i_*k(p)$ is the residue field module κ_p .

(ii) Let $Y \xrightarrow{i} X$ be the inclusion of a closed subvariety, and let \mathcal{I} be the ideal of Y in \mathcal{O}_Y . The extension by zero of the structure sheaf on Y fits into an exact sequence of \mathcal{O}_X -modules

$$0 \rightarrow \mathcal{I} \rightarrow \mathcal{O}_X \rightarrow i_*\mathcal{O}_Y \rightarrow 0$$

So the extension by zero $i_*\mathcal{O}_Y$ is isomorphic to the quotient module $\mathcal{O}_X/\mathcal{I}$. □

izero

6.5.5. Proposition. Let $Y \xrightarrow{i} X$ be the inclusion of a closed subvariety Y into a variety X , and let \mathcal{I} be the ideal of Y . Let \mathbb{M} denote the subcategory of the category of \mathcal{O}_X -modules that are annihilated by \mathcal{I} . Extension by zero defines an equivalence of categories

$$(\mathcal{O}_Y\text{-modules}) \xrightarrow{i_*} \mathbb{M}$$

proof. Let f be a section of \mathcal{O}_X on an affine open set U , let \bar{f} be its restriction to $U \cap Y$, and let α be an element of $[i_*\mathcal{N}](U)$ ($= \mathcal{N}(U \cap Y)$). So multiplication by f is defined by restriction of scalars: $f\alpha = \bar{f}\alpha$. If f is in $\mathcal{I}(U)$, then $\bar{f} = 0$ and therefore $f\alpha = \bar{f}\alpha = 0$. So the extension by zero of an \mathcal{O}_Y -module is annihilated by \mathcal{I} . The direct image $i_*\mathcal{N}$ is an object of \mathbb{M} .

We construct an inverse to the direct image. Starting with an \mathcal{O}_X -module \mathcal{M} that is annihilated by \mathcal{I} , we construct an \mathcal{O}_Y -module \mathcal{N} such that $i_*\mathcal{N}$ is isomorphic to \mathcal{M} .

Let Y' be an open subset of Y . The topology on Y is induced from the topology on X , so $Y' = X_1 \cap Y$ for some open subset X_1 of X . We try to set $\mathcal{N}(Y') = \mathcal{M}(X_1)$. To show that this is well-defined, we show that if X_2 is another open subset of X such that $Y' = X_2 \cap Y$, then $\mathcal{M}(X_2)$ is isomorphic to $\mathcal{M}(X_1)$. Let $X_3 = X_1 \cap X_2$. Then it is also true that $Y' = X_3 \cap Y$. Since $X_3 \subset X_1$, we have a map $\mathcal{M}(X_1) \rightarrow \mathcal{M}(X_3)$, and it suffices to show that this map is an isomorphism. The same reasoning will give us an isomorphism $\mathcal{M}(X_2) \rightarrow \mathcal{M}(X_3)$.

The complement $U = X_1 - Y'$ of Y' in X_1 is an open subset of X_1 and of X , and $U \cap Y = \emptyset$. We cover U by a set $\{U^i\}$ of affine open sets. Then X_1 is covered by the open sets $\{U^i\}$ together with X_3 . The restriction of \mathcal{I} to each of the sets U^i is the unit ideal, and since \mathcal{I} annihilates \mathcal{M} , $\mathcal{M}(U^i) = 0$. The sheaf property shows that $\mathcal{M}(X_1)$ is isomorphic to $\mathcal{M}(X_3)$. The rest of the proof, checking localization and verifying that \mathcal{N} is unique, is boring. □

in-
cludeopen

(6.5.6) inclusion of an open set

Let $Y \xrightarrow{j} X$ be the inclusion of an **open** subvariety Y into a variety X .

First, restriction from X to Y . Since open subsets of Y are also open subsets of X , we can *restrict* an \mathcal{O} -module \mathcal{M} from X to Y . By definition, the sections of the restricted module on a subset U of Y are simply the elements of $\mathcal{M}(U)$. For example, the restriction of the structure sheaf \mathcal{O}_X to Y is the structure sheaf \mathcal{O}_Y . We use subscript notation, writing \mathcal{M}_Y for the restriction of an \mathcal{O}_X -module \mathcal{M} to Y , then denoting the given module \mathcal{M} by \mathcal{M}_X for clarity. If U is an open subset of Y ,

$$(6.5.7) \quad \mathcal{M}_Y(U) = \mathcal{M}_X(U)$$

restr-
toopen

Now the direct image: Let $Y \xrightarrow{j} X$ be the inclusion of an open subvariety Y , and let \mathcal{N} be an \mathcal{O}_Y -module. The inverse image of an open subset U of X is the intersection $Y \cap U$. By definition, the direct image is

$$[j_*\mathcal{N}](U) = \mathcal{N}(Y \cap U)$$

For example, $[j_*\mathcal{O}_Y](U)$ is the algebra of rational functions on X that are regular on $Y \cap U$. They needn't be regular on U .

6.5.8. Example. Let $X_s \xrightarrow{j} X$ be the inclusion of a localization into an affine variety $X = \text{Spec } A$. Modules on X correspond to their global sections, which are A -modules. Similarly, modules on X_s correspond to A_s -modules. We can restrict the \mathcal{O}_X -module \mathcal{M}_X that corresponds to an A -module M to the open set X_s , obtaining the \mathcal{O}_{X_s} -module \mathcal{M}_{X_s} that corresponds to the A_s -module M_s . Then M_s is also the module of global sections of $j_*\mathcal{M}_{X_s}$ on X :

exam-
pledirec-
timage

$$[j_*\mathcal{M}_{X_s}](X) = \mathcal{M}_{X_s}(X_s) = M_s$$

The localization M_s is made into an A -module by restriction of scalars.

The reversal of arrows when one passes from affine varieties to their coordinate algebras seems especially confusing here. \square

6.5.9. Proposition. Let $Y \xrightarrow{j} X$ be the inclusion of an open subvariety Y into a variety X .

fstarexact

- (i) The restriction $\mathcal{O}_X\text{-modules} \rightarrow \mathcal{O}_Y\text{-modules}$ is an exact operation.
- (ii) If Y is an **affine** open subvariety of X , the direct image functor j_* is exact.
- (iii) Let $\mathcal{M} = \mathcal{M}_X$ be an \mathcal{O}_X -module. There is a canonical homomorphism $\mathcal{M}_X \rightarrow j_*[\mathcal{M}_Y]$.

proof. (ii) Let U be an affine open subset of X , and let $\mathcal{M} \rightarrow \mathcal{N} \rightarrow \mathcal{P}$ be an exact sequence of \mathcal{O}_Y -modules. The sequence $j_*\mathcal{M}(U) \rightarrow j_*\mathcal{N}(U) \rightarrow j_*\mathcal{P}(U)$ is the same as the sequence $\mathcal{M}(U \cap Y) \rightarrow \mathcal{N}(U \cap Y) \rightarrow \mathcal{P}(U \cap Y)$, though the scalars have changed. Since U and Y are affine, $U \cap Y$ is affine. By definition of exactness, this sequence is exact.

(iii) Let U be open in X . Then $j_*\mathcal{M}_Y(U) = \mathcal{M}(U \cap Y)$. Since $U \cap Y \subset U$, $\mathcal{M}(U)$ maps to $\mathcal{M}(U \cap Y)$. \square

6.5.10. Example. Let $X = \mathbb{P}^n$ and let j denote the inclusion $\mathbb{U}^0 \subset X$ of the standard affine open subset into X . The direct image $j_*\mathcal{O}_{\mathbb{U}^0}$ is the algebra of rational functions that are allowed to have poles on the hyperplane at infinity.

dirim-
standaffine

The inverse image of an open subset W of X is its intersection with \mathbb{U}^0 : $j^{-1}W = W \cap \mathbb{U}^0$. The sections of the direct image $j_*\mathcal{O}_{\mathbb{U}^0}$ on an open subset W of X are the regular functions on $W \cap \mathbb{U}^0$:

$$[j_*\mathcal{O}_{\mathbb{U}^0}](W) = \mathcal{O}_{\mathbb{U}^0}(W \cap \mathbb{U}^0) = \mathcal{O}_X(W \cap \mathbb{U}^0)$$

Say that we write a rational function α as a fraction g/h of relatively prime polynomials. Then α is an element of $\mathcal{O}_X(W)$ if h doesn't vanish at any point of W , and α is a section of $[j_*\mathcal{O}_{\mathbb{U}^0}](W) = \mathcal{O}_X(W \cap \mathbb{U}^0)$ if h doesn't vanish on $W \cap \mathbb{U}^0$. Arbitrary powers of x_0 can appear in the denominator h when α is a section of $j_*\mathcal{O}_{\mathbb{U}^0}$. \square

6.6 Support

(6.6.1) annihilators

annand-
supph

Let A be a ring, and let m be an element of an A -module M . The *annihilator* I of an element m of M is the set of elements α of A such that $\alpha m = 0$. It is an ideal of A that is often denoted by $\text{ann}(m)$.

The *annihilator of an A -module M* is the set of elements of A such that $aM = 0$. This annihilator is also an ideal.

6.6.2. Lemma. Let I be the annihilator of an element m of M , and let s be a nonzero element of A . The annihilator of the image of m in the localized module M_s is the localized ideal I_s . \square

localize-
support

This lemma allows us to extend the concept of annihilator to sections of a finite \mathcal{O} -module on a variety X .

When \mathcal{I} is an ideal of \mathcal{O} , we denote by $V_X(\mathcal{I})$ the closed set of points p such that $\mathcal{I} \subset \mathfrak{m}_p$ – such that all elements of \mathcal{I} vanish.

6.6.3. Support. Let M be a finite module over a finite-type domain A and $X = \text{Spec } A$. The *support* of M is the locus $C = V_X(I)$ of zeros of its annihilator I in X . It is the set of points p of X such that $I \subset \mathfrak{m}_p$. The support of a finite module is a closed subset of X . If s is a nonzero element of A , the support of the localized module M_s is the intersection $C_s = C \cap X_s$.

Let \mathcal{M} be a finite \mathcal{O} -module on a variety X , and let \mathcal{I} be its annihilator. The *support* of \mathcal{M} is the closed subset $V_X(\mathcal{I})$ of points such that $\mathcal{I} \subset \mathfrak{m}_p$. For example, the support of the residue field module κ_p is the point p . The support of the maximal ideal \mathfrak{m}_p at p is the whole variety X .

support-
dimzero
suppfinite

(6.6.4) \mathcal{O} -modules with support of dimension zero

6.6.5. Proposition. *Let \mathcal{M} be a finite \mathcal{O} -module on a variety X .*

(i) *Suppose that the support of \mathcal{M} is a single point p , let $M = \mathcal{M}(X)$, and let U be an affine open subset of X . If U contains p , then $\mathcal{M}(U) = M$, and if U doesn't contain p , then $\mathcal{M}(U) = 0$.*

(ii) *(Chinese Remainder Theorem) If the support of \mathcal{M} is a finite set $\{p_1, \dots, p_k\}$, then \mathcal{M} is the direct sum $\mathcal{M}_1 \oplus \dots \oplus \mathcal{M}_k$ of \mathcal{O} -modules supported at the points p_i .*

proof. **(i)** Let \mathcal{I} be the annihilator of \mathcal{M} . The locus $V_X(\mathcal{I})$ is p . If p isn't contained in U , then when we restrict \mathcal{M} to U , we obtain an \mathcal{O}_U -module whose support is empty. Therefore \mathcal{I} is the unit ideal, and the restriction to U is the zero module.

Next, suppose that p is contained in U , and let V denote the complement of p in X . We cover X by a set $\{U^i\}$ of affine open sets with $U = U^1$, and such that $U^i \subset V$ if $i > 1$. By what has been shown, $\mathcal{M}(U^i) = 0$ if $i > 0$ and $\mathcal{M}(U^{i_j}) = 0$ if $j \neq i$. The sheaf axiom for this covering shows that $\mathcal{M}(X) \approx \mathcal{M}(U)$.

(ii) This follows from the ordinary Chinese Remainder Theorem. □

6.7 Twisting

twisting-
modules

The twisting modules that we define here are among the most important modules on projective space.

Let X denote the projective space \mathbb{P}^d with coordinates x_0, \dots, x_d . As before, a homogeneous fraction of degree n is a fraction g/h of homogeneous polynomials with $\deg g - \deg h = d$. When g and h are relatively prime, the fraction g/h is *regular* on an open subset V of X if h isn't zero at any point of V .

The definition of the twisting modules is this: The sections of $\mathcal{O}(n)$ on an open subset V of \mathbb{P}^n are the homogeneous fractions of degree n that are regular on V . Thus $\mathcal{O} = \mathcal{O}(0)$.

Odismod-
ule

6.7.1. Proposition.

(i) *Let V be an affine open subset of \mathbb{P}^n that is contained in the standard affine open set \mathbb{U}^0 . The sections of $\mathcal{O}(n)$ on V form a free module of rank one with basis x_0^n , over the coordinate algebra $\mathcal{O}(V)$.*

(ii) *The twisting module $\mathcal{O}(n)$ is an \mathcal{O} -module.*

proof. **(i)** Let V be an open set contained in \mathbb{U}^0 , and let α be a section of $\mathcal{O}(n)$ on V . Then $f = \alpha x_0^{-n}$ has degree zero. It is a rational function. Since $V \subset \mathbb{U}^0$, x_0 doesn't vanish at any point of V . Since α is regular on V , f is a regular function on V , and $\alpha = f x_0^n$.

(ii) It is clear that $\mathcal{O}(n)$ is a contravariant functor. We verify compatibility with localization. Let $V = \text{Spec } A$ be an affine open subset of X and let s be a nonzero element of A . We must show that $[\mathcal{O}(n)](V_s)$ is the localization of $[\mathcal{O}(n)](V)$. We already know that $[\mathcal{O}(n)](V)$ is a subset of $[\mathcal{O}(n)](V_s)$. What has to be shown is that if β is a section of $\mathcal{O}(n)$ on V_s , then $s^k \beta$ is a section on V , if k is sufficiently large.

We cover V by the affine open sets $V^i = V \cap \mathbb{U}^i$. To show that $s^k \beta$ is a section on V , it suffices to show that it is a section on $V \cap \mathbb{U}^i$ for every i . This is the sheaf property. We apply **(i)** to the open subset V_s^0 of V^0 . Since V_s^0 is contained in \mathbb{U}^0 , β can be written (uniquely) in the form $f x_0^n$, where f is a rational function that is regular on V_s^0 . We know already that \mathcal{O} has the coherence property. Therefore $s^k f$ is a regular function on V^0 if k is large, and then $s^k \alpha = s^k f x_0^n$ is a section of $\mathcal{O}(n)$ on V^0 . The analogous statement is true for every index i . □

As part **(i)** of the proposition shows, $\mathcal{O}(n)$ is quite similar to the structure sheaf. However, $\mathcal{O}(n)$ is only *locally* free. Its sections on the standard open set \mathbb{U}^1 form a free $\mathcal{O}(\mathbb{U}^1)$ -module with basis x_1^n . That basis is related to the basis x_0^n on \mathbb{U}^0 by the factor $(x_0/x_1)^n$, a rational function that isn't invertible on \mathbb{U}^0 or on \mathbb{U}^1 .

6.7.2. Proposition. *When $d \geq 0$, the global sections of the twisting module $\mathcal{O}(n)$ on \mathbb{P}^n are the homogeneous polynomials of degree n . When $n < 0$, the only global section of $\mathcal{O}(n)$ is zero.*

sectionsofOn

proof. A nonzero global section u of $\mathcal{O}(n)$ will restrict to a section on the standard affine open set \mathbb{U}^0 . Since elements of $\mathcal{O}(\mathbb{U}^0)$ are homogeneous fractions of degree zero whose denominators are powers of x_0 , and since $[\mathcal{O}(n)](\mathbb{U}^0)$ is a free module over $\mathcal{O}(\mathbb{U}^0)$ with basis x_0^d , u will have the form g/x_0^m for some homogeneous polynomial g and some m . Similarly, restriction to \mathbb{U}^1 shows that u has the form g_1/x_1^k . It follows that $m = k = 0$ and that $u = g$. Since u has degree n , g will have degree n . \square

6.7.3. Examples.

prodhomfr

The product uv of homogeneous fractions of degrees r and s is a homogeneous fraction of degree $r + s$, and if u and v are regular on an open set V , so is their product uv . So multiplication defines a homomorphism of \mathcal{O} -modules

$$(6.7.4) \quad \mathcal{O}(r) \times \mathcal{O}(s) \rightarrow \mathcal{O}(r+s)$$

oros

Multiplication by a homogeneous polynomial f of degree n defines an injective homomorphism

$$(6.7.5) \quad \mathcal{O}(k) \xrightarrow{f} \mathcal{O}(k+n).$$

multby-fone

When $k = -n$, this becomes a homomorphism $\mathcal{O}(-n) \xrightarrow{f} \mathcal{O}$. \square

The twisting modules $\mathcal{O}(n)$ have a second interpretation. They are isomorphic to the modules that we denote by $\mathcal{O}(nH)$, of rational functions on projective space \mathbb{P}^d with poles of order at most n on the hyperplane $H : \{x_0 = 0\}$ at infinity.

By definition, the nonzero sections of $\mathcal{O}(nH)$ on an open set V are the rational functions f such that $x_0^n f$ is a section of $\mathcal{O}(n)$ on V . Thus multiplication by x_0^n defines an isomorphism

$$(6.7.6) \quad \mathcal{O}(nH) \xrightarrow{x_0^n} \mathcal{O}(n)$$

OnOnH

If f is a section of $\mathcal{O}(nH)$ on an open set V , and if we write f as a homogeneous fraction g/h of degree zero, with g, h relatively prime, the denominator h may have x_0^k , with $k \leq n$, as factor. The other factors of h cannot vanish anywhere on V . If $f = g/h$ is a global section of $\mathcal{O}(nH)$, then $h = cx_0^k$, with $c \in \mathbb{C}$ and $k \leq n$. A global section of $\mathcal{O}(nH)$ can be represented as a fraction g/x_0^k .

Since x_0 doesn't vanish at any point of the standard affine open set \mathbb{U}^0 , the sections of $\mathcal{O}(nH)$ on an open subset V of \mathbb{U}^0 are simply the regular functions on V . The restrictions of $\mathcal{O}(nH)$ and \mathcal{O} to \mathbb{U}^0 are equal. Using the subscript notation (6.5.6) for restriction to an open set,

$$(6.7.7) \quad \mathcal{O}(nH)_{\mathbb{U}^0} = \mathcal{O}_{\mathbb{U}^0}$$

jstarOH

Let V be an open subset of one of another standard affine open sets, say of \mathbb{U}^1 . The ideal of $H \cap \mathbb{U}^1$ in \mathbb{U}^1 is principal, generated by $v_0 = x_0/x_1$, and v_0 generates the ideal of $H \cap V$ in V too. If f is a rational function, then because x_1 doesn't vanish on \mathbb{U}^1 , the function fv_0^n will be regular on V if and only if the homogeneous fraction fx_0^n is regular there. So f will be a section of $\mathcal{O}(nH)$ on V if and only if fv_0^n is a regular function. Because v_0 generates the ideal of H in V , we say that such a function f has a pole of order at most n on H .

The isomorphic \mathcal{O} -modules $\mathcal{O}(n)$ and $\mathcal{O}(nH)$ are interchangeable. The twisting module $\mathcal{O}(n)$ is often better because its definition is independent of coordinates. On the other hand, $\mathcal{O}(nH)$ can be convenient because its restriction to \mathbb{U}^0 is the structure sheaf $\mathcal{O}_{\mathbb{U}^0}$.

6.7.8. Proposition. *Let Y be the zero locus of an irreducible homogeneous polynomial f of degree n (a hypersurface of degree n in \mathbb{P}^n), let \mathcal{I} be the ideal of Y , and let $\mathcal{O}(-n)$ be the twisting module on X . Multiplication by f defines an isomorphism $\mathcal{O}(-n) \xrightarrow{f} \mathcal{I}$.*

curveideal

proof. If α is a section of $\mathcal{O}(-n)$ on an open set V , then $f\alpha$ will be a rational function that is regular on V and that vanishes on $Y \cap V$. Therefore the image of the multiplication map $\mathcal{O}(-n) \xrightarrow{f} \mathcal{O}$ is contained in \mathcal{I} . This map is injective because $\mathbb{C}[x_0, \dots, x_n]$ is a domain. To show that it is an isomorphism, it suffices to show that its restrictions to the standard affine open sets \mathbb{U}^i are surjective. (6.3.6). As usual, we work with \mathbb{U}^0 , and we will show that the multiplication map $\mathcal{O}(-n) \rightarrow \mathcal{I}$ is surjective on \mathbb{U}^0 .

We can choose our coordinates generically, so we may suppose that f isn't a scalar multiple of any x_i . Then $Y \cap \mathbb{U}^0$ will be a dense open subset of Y . The sections of \mathcal{O} on \mathbb{U}^0 are the homogeneous fractions g/x_0^k of degree zero. Such a fraction is a section of \mathcal{I} on \mathbb{U}^0 if and only if g vanishes on $Y \cap \mathbb{U}^0$. If so, then since $Y \cap \mathbb{U}^0$ is dense in Y and since the zero set of g is closed, g will vanish on Y , and therefore it will be divisible by f : $g = fq$. The sections of \mathcal{I} on \mathbb{U}^0 have the form fq/x_0^k . They are in the image of the map $\mathcal{O}(-n) \rightarrow \mathcal{I}$. \square

The proposition has an interesting corollary:

idealsisom

6.7.9. Corollary. *When regarded as \mathcal{O} -modules, the ideals of all hypersurfaces of degree n are isomorphic.*

twistmod-
ule
deftwistm

(6.7.10) twisting a module

6.7.11. Definition Let \mathcal{M} be an \mathcal{O} -module on projective space \mathbb{P}^d , and let $\mathcal{O}(n)$ be the twisting module. The n th twist of \mathcal{M} is defined to be the tensor product $\mathcal{M}(n) = \mathcal{M} \otimes_{\mathcal{O}} \mathcal{O}(n)$. Similarly, $\mathcal{M}(nH) = \mathcal{M} \otimes_{\mathcal{O}} \mathcal{O}(nH)$. Twisting is a functor on \mathcal{O} -modules.

If X is a closed subvariety of \mathbb{P}^d and \mathcal{M} is an \mathcal{O}_X -module, $\mathcal{M}(n)$ and $\mathcal{M}(nH)$ are obtained by twisting the extension of \mathcal{M} by zero. (See the equivalence of categories (6.5.5)).

Since x_0^n is a basis of $\mathcal{O}(n)$ on \mathbb{U}^0 , a section of $\mathcal{M}(n)$ on an open subset V of \mathbb{U}^0 can be written in the form $\mu = m \otimes fx_0^n$, where f is a regular function on V and m is a section of \mathcal{M} on V (6.7.1). The function f can be moved over to m , so μ can also be written in the form $\mu = m \otimes x_0^n$, and this expression is unique.

limOnH

6.7.12. The modules $\mathcal{O}(n)$ and $\mathcal{O}(nH)$ form directed sets that are related by a diagram

$$(6.7.13) \quad \begin{array}{ccccccc} \mathcal{O} & \xrightarrow{\subset} & \mathcal{O}(H) & \xrightarrow{\subset} & \mathcal{O}(2H) & \xrightarrow{\subset} & \dots \\ \parallel & & x_0 \downarrow & & x_0^2 \downarrow & & \\ \mathcal{O} & \xrightarrow{x_0} & \mathcal{O}(1) & \xrightarrow{x_0} & \mathcal{O}(2) & \longrightarrow & \dots \end{array}$$

Oninclu-
sions

In this diagram, the vertical arrows are bijections and the horizontal arrows are injective. The limit of the upper directed set is the module whose sections are allowed to have arbitrary poles on H . This is also the module $j_*\mathcal{O}_{\mathbb{U}^0}$, where j denotes the inclusion of the standard affine open set \mathbb{U}^0 into X (see (6.5.9) (iii)):

limequal-
sjstar

$$(6.7.14) \quad \varinjlim \mathcal{O}(nH) = j_*\mathcal{O}_{\mathbb{U}^0}$$

The next diagram is obtained by tensoring Diagram 6.7.13 with \mathcal{M} .

Mnmaps

$$(6.7.15) \quad \begin{array}{ccccccc} \mathcal{M} & \longrightarrow & \mathcal{M}(H) & \longrightarrow & \mathcal{M}(2H) & \longrightarrow & \dots \\ \parallel & & x_0 \downarrow & & x_0^2 \downarrow & & \\ \mathcal{M} & \xrightarrow{1 \otimes x_0} & \mathcal{M}(1) & \xrightarrow{1 \otimes x_0} & \mathcal{M}(2) & \longrightarrow & \dots \end{array}$$

Here, the vertical maps are bijective, but because \mathcal{M} may have torsion, the horizontal maps needn't be injective. However, since tensor products are compatible with limits,

limjstar

$$(6.7.16) \quad \varinjlim \mathcal{M}(nH) = \varinjlim \mathcal{M} \otimes_{\mathcal{O}} \mathcal{O}(nH) = \mathcal{M} \otimes_{\mathcal{O}} j_*\mathcal{O} \approx j_*\mathcal{M}_{\mathbb{U}^0}$$

The last isomorphism needs explanation:

6.7.17. Lemma. Let \mathcal{M} be an \mathcal{O} -module on projective space, and let $\mathbb{U} \xrightarrow{j} \mathbb{P}^d$ be the inclusion of the standard affine open set $\mathbb{U} = \mathbb{U}^0$. Then $\mathcal{M} \otimes_{\mathcal{O}} j_* \mathcal{O}_{\mathbb{U}}$ and $j_* \mathcal{M}_{\mathbb{U}}$ are isomorphic.

Mjstare-
qualjs-
tarM

proof. Let $\alpha \otimes f$ be a section of $\mathcal{M} \otimes j_* \mathcal{O}_{\mathbb{U}}$ on an open set V , where α is a section of \mathcal{M} on V and f is a regular function on $V \cap \mathbb{U}$. Then, denoting the restriction of α to $V \cap \mathbb{U}$ by the same symbol, αf will be a section of \mathcal{M} on $V \cap \mathbb{U}$ and therefore a section of $j_* \mathcal{M}_{\mathbb{U}}$ on V . Sending $\alpha \otimes f$ to αf defines a homomorphism $\mathcal{M} \otimes_{\mathcal{O}} j_* \mathcal{O}_{\mathbb{U}} \rightarrow j_* \mathcal{M}_{\mathbb{U}}$. To show that this map is an isomorphism, it suffices to verify that it defines a bijective map on each of the standard affine open sets \mathbb{U}^i . We leave the case $i = 0$ as exercise and look at \mathbb{U}^1 . On that open set, $[j_* \mathcal{M}_{\mathbb{U}}](\mathbb{U}^1) = \mathcal{M}(\mathbb{U}^{01})$. Also, $[j_* \mathcal{O}_{\mathbb{U}^0}](\mathbb{U}^1) = \mathcal{O}_{\mathbb{U}^0}(\mathbb{U}^0 \cap \mathbb{U}^1)$, so by definition of the tensor product,

$$[\mathcal{M} \otimes_{\mathcal{O}} j_* \mathcal{O}_{\mathbb{U}^0}](\mathbb{U}^1) = \mathcal{M}(\mathbb{U}^1) \otimes_{\mathcal{O}(\mathbb{U}^1)} \mathcal{O}(\mathbb{U}^0 \cap \mathbb{U}^1) = \mathcal{M}(\mathbb{U}^1)[x_0^{-1}] = \mathcal{M}(\mathbb{U}^{01})$$

□

(6.7.18) generating an \mathcal{O} -module

generators

Let \mathcal{M} be an \mathcal{O} -module on a variety X , and let $m = (m_1, \dots, m_k)$ be a set of global sections of \mathcal{M} . This set defines a map

$$(6.7.19) \quad \mathcal{O}^k \xrightarrow{m} \mathcal{M}$$

gen

that sends a section $(\alpha_1, \dots, \alpha_k)$ of \mathcal{O}^k on an open set to the combination $\sum \alpha_i m_i$. The global sections m_1, \dots, m_k generate \mathcal{M} if this map is surjective. If the sections generate \mathcal{M} , then they (more precisely, their restrictions), generate the $\mathcal{O}(U)$ -module $\mathcal{M}(U)$ for every affine open set U . They may fail to generate $\mathcal{M}(U)$ when U isn't affine.

6.7.20. Example. Let $X = \mathbb{P}^1$. For $n \geq 0$, the global sections of the twisting module $\mathcal{O}(n)$ are the polynomials of degree n in the coordinate variables x_0, x_1 (6.7.2). Consider the map $\mathcal{O}^2 \xrightarrow{(x_0^n, x_1^n)} \mathcal{O}(n)$. On \mathbb{U}^0 , $\mathcal{O}(n)$ has basis x_0^n . Therefore this map is surjective on \mathbb{U}^0 . Similarly, it is surjective on \mathbb{U}^1 . So it is a surjective map on all of X (6.3.6). The global sections x_0^n, x_1^n generate $\mathcal{O}(n)$. However, the global sections of $\mathcal{O}(n)$ are the homogeneous polynomials of degree n . When $n > 1$, the two sections x_0^n, x_1^n don't span the space of global sections, and the map $\mathcal{O}^2 \xrightarrow{(x_0^n, x_1^n)} \mathcal{O}(n)$ isn't surjective. □

generate-
example

The next theorem explains the importance of the twisting operation.

6.7.21. Theorem. Let \mathcal{M} be a finite \mathcal{O} -module on a projective variety X . For large k , the twist $\mathcal{M}(k)$ is generated by global sections.

gentwist

proof. We may assume that X is projective space \mathbb{P}^n .

We are to show that if \mathcal{M} is a finite \mathcal{O} -module, the global sections generate $\mathcal{M}(k)$ when k is large, and it suffices to show that for each $i = 0, \dots, n$, the restrictions of those global sections to \mathbb{U}^i generate the $\mathcal{O}(\mathbb{U}^i)$ -module $[\mathcal{M}(k)](\mathbb{U}^i)$ (6.3.6). We work with the index $i = 0$ as usual.

We replace $\mathcal{M}(k)$ by the isomorphic module $\mathcal{M}(kH)$. We recall that the restriction of $\mathcal{M}(kH)$ to \mathbb{U}^0 is equal to $\mathcal{M}_{\mathbb{U}^0}$, and that $\varinjlim \mathcal{M}(kH) = j_* \mathcal{M}_{\mathbb{U}^0}$ (6.7.16).

Let $A_0 = \mathcal{O}(\mathbb{U}^0)$, and $M_0 = \mathcal{M}(\mathbb{U}^0)$. The global sections of $j_* \mathcal{M}_{\mathbb{U}^0}$ are the sections of \mathcal{M} on \mathbb{U}^0 , which we are denoting by M_0 . We choose a finite set of generators m_1, \dots, m_r for the finite A_0 -module M_0 . These generators are global sections of $j_* \mathcal{M}_{\mathbb{U}^0}$, and since $\varinjlim \mathcal{M}(kH) = j_* \mathcal{M}_{\mathbb{U}^0}$, the sections m_i are represented by global sections m'_1, \dots, m'_r of $\mathcal{M}(kH)$ when k is large. The restrictions of m_i and m'_i to \mathbb{U}^0 are equal, so the restrictions of m'_1, \dots, m'_r generate M_0 too. Then M_0 is generated by global sections of $\mathcal{M}(kH)$, as was to be shown. □

6.8 Proof of Theorem 6.3.2.

The statement to be proved is that an \mathcal{O} -module \mathcal{M} on a variety X has a unique extension to a functor

proveex-
tension

$$(\text{opens}) \xrightarrow{\widetilde{\mathcal{M}}} (\text{modules})$$

that has the sheaf property (6.3.5),(6.3.10) and that a homomorphism $\mathcal{M} \rightarrow \mathcal{N}$ of \mathcal{O} -modules has a unique extension to a homomorphism $\widetilde{\mathcal{M}} \rightarrow \widetilde{\mathcal{N}}$.

The proof has the following steps:

1. Verification of the sheaf property for a covering of an affine open set by localizations.
2. Extension of the functor \mathcal{M} to all morphisms between affine open sets, not just to localizations.
3. Definition of $\widetilde{\mathcal{M}}$.

Step 1. (*the sheaf property for a covering of an affine open set by localizations*)

This point was discussed before, in Section 6.3.3. Suppose that an affine open set $Y = \text{Spec } A$ is covered by a family of localizations $\mathbb{U}_0 = \{U^{s_i}\}$, let \mathcal{M} be an \mathcal{O} -module, and let $M = \mathcal{M}(Y)$, $M_i = \mathcal{M}(U^{s_i})$, and $M_{ij} = \mathcal{M}(U^{s_i s_j})$. The exact sequence that expresses the sheaf property for the covering diagram $Y \leftarrow \mathbb{U}_0 \rightrightarrows \mathbb{U}_1$ becomes

$$(6.8.1) \quad 0 \rightarrow M \xrightarrow{\alpha} \prod M_i \xrightarrow{\beta} \prod M_{ij}$$

In this sequence, the map α sends an element m of M to the vector (m, \dots, m) of its images in $\prod_i M_i$, and β sends a vector (m_1, \dots, m_k) in $\prod_i M_i$ to the matrix (z_{ij}) , with $z_{ij} = m_j - m_i$ in M_{ij} . To be precise, M_i and M_j map to M_{ij} , and z_{ij} is the difference of their images. We must show that the sequence (6.8.1) is exact.

exactness at M : Since the open sets U^i cover Y , the elements s_1, \dots, s_k generate the unit ideal. Let m be an element of M that maps to zero in every M_i . Then there exists an n such that $s_i^n m = 0$, and we can use the same exponent n for all i (see ??). The elements s_i^n generate the unit ideal. Writing $\sum a_i s_i^n = 1$, we have $m = \sum a_i s_i^n m = \sum a_i 0 = 0$.

exactness at $\prod M_i$: Let m_i be elements of M_i such that $m_j = m_i$ in M_{ij} for all i, j . We must find an element w in M that maps to m_j in M_j for every j .

We write m_i as a fraction: $m_i = s_i^{-n} x_i$, or $x_i = s_i^n m_i$, with x_i in M , using the same integer n for all i . The equation $m_j = m_i$ in M_{ij} tells us that $s_i^n x_j = s_j^n x_i$ in M_{ij} , and then $(s_i s_j)^r s_i^n x_j = (s_i s_j)^r s_j^n x_i$ will be true in M , if r is large (see 2.6.5).

We adjust the notation. Let $\tilde{x}_i = s_i^r x_i$, and $\tilde{s}_i = s_i^{r+n}$. Then in M , $\tilde{x}_i = \tilde{s}_i m_i$ and $\tilde{s}_j \tilde{x}_i = \tilde{s}_i \tilde{x}_j$. The elements \tilde{s}_i generate the unit ideal. So there is an equation in A , of the form $\sum a_i \tilde{s}_i = 1$. Let $w = \sum a_i \tilde{x}_i$. This is an element of M , and

$$\tilde{x}_j = \left(\sum_i a_i \tilde{s}_i \right) \tilde{x}_j = \sum_i a_i \tilde{s}_j \tilde{x}_i = \tilde{s}_j w$$

Since $m_j = \tilde{s}_j^{-1} \tilde{x}_j$, $m_j = w$ is true in M_j . Since j is arbitrary, w is the required element of M . □

Step 2. (*extending an \mathcal{O} -module to all morphisms between affine open sets*)

The \mathcal{O} -module \mathcal{M} comes with localization maps $\mathcal{M}(U) \rightarrow \mathcal{M}(U_s)$. It doesn't come with homomorphisms $\mathcal{M}(U) \rightarrow \mathcal{M}(V)$ when $V \rightarrow U$ is an arbitrary inclusion of affine open sets. We define those maps here.

Let \mathcal{M} be an \mathcal{O} -module and let $V \rightarrow U$ be an inclusion of affine open sets. To describe the canonical homomorphism $\mathcal{M}(U) \rightarrow \mathcal{M}(V)$, we cover V by a family $\mathbb{V}_0 = \{V^i\}$ of open sets that are localizations of U and therefore also localizations of V , and we inspect the covering diagram $V \leftarrow \mathbb{V}_0 \rightrightarrows \mathbb{V}_1$ and the corresponding exact sequence $0 \rightarrow \mathcal{M}(V) \xrightarrow{\alpha} \mathcal{M}(\mathbb{V}_0) \xrightarrow{\beta} \mathcal{M}(\mathbb{V}_1)$. We add the map $V \rightarrow U$ to the covering diagram:

$$U \leftarrow V \leftarrow \mathbb{V}_0 \rightrightarrows \mathbb{V}_1$$

Since V^i are localizations of U and V^{ij} are localizations of V^i and of V^j , the \mathcal{O} -module \mathcal{M} comes with maps $\mathcal{M}(U) \xrightarrow{\psi} \mathcal{M}(\mathbb{V}_0) \rightrightarrows \mathcal{M}(\mathbb{V}_1)$. Let ψ be the map $\mathcal{M}(U) \rightarrow \mathcal{M}(\mathbb{V}_0)$. The two composed maps $U \leftarrow V \rightrightarrows \mathbb{V}_1$ are equal, and so are the maps $\mathcal{M}(U) \rightrightarrows \mathcal{M}(\mathbb{V}_1)$. Their difference, which is $\beta\psi$, is the zero map. Therefore ψ maps $\mathcal{M}(U)$ to the kernel of β which, according to Step 1, is $\mathcal{M}(V)$. This gives us a map $\mathcal{M}(U) \xrightarrow{\eta} \mathcal{M}(V)$ that makes a diagram

$$(6.8.2) \quad \begin{array}{ccc} \mathcal{M}(U) & \xrightarrow{\eta} & \mathcal{M}(V) \\ \parallel & & \alpha \downarrow \\ \mathcal{M}(U) & \xrightarrow{\psi} & \mathcal{M}(\mathbb{V}_0) \end{array}$$

localize-
module

UtoV

Both ψ and α are compatible with multiplication by a regular function f on U , and α is injective. So η is also compatible with multiplication by f . We must check that η is independent of the covering \mathbb{V}_0 . Let $\mathbb{V}'_0 = \{V'^j\}$ be another covering of V by localizations of U . We cover each of the open sets $V^i \cap V'^j$ by localizations $W^{ij\nu}$ of U . Taken together, these open sets form a covering \mathbb{W}_0 of V . We have a map $\mathbb{W}_0 \xrightarrow{\epsilon} \mathbb{V}_0$ that gives us a map of covering diagrams

$$[W \rightarrow \mathbb{W}_0 \rightrightarrows \mathbb{W}_1] \longrightarrow [V \rightarrow \mathbb{V}_0 \rightrightarrows \mathbb{V}_1]$$

and therefore a diagram

$$(6.8.3) \quad \begin{array}{ccccccc} 0 & \longrightarrow & \mathcal{M}(V) & \longrightarrow & \mathcal{M}(\mathbb{V}_0) & \xrightarrow{\beta_{\mathbb{V}}} & \mathcal{M}(\mathbb{V}_1) \\ & & \parallel & & \downarrow & & \downarrow \\ 0 & \longrightarrow & \mathcal{M}(V) & \longrightarrow & \mathcal{M}(\mathbb{W}_0) & \xrightarrow{\beta_{\mathbb{W}}} & \mathcal{M}(\mathbb{W}_1) \end{array}$$

compare-cov

whose rows are exact sequences.

Also, \mathbb{V}_0 covers U , so $\mathcal{M}(U)$ maps to $\mathcal{M}(\mathbb{V}_0)$, and the composed maps $\mathbb{V}_1 \rightrightarrows \mathbb{V}_0 \rightarrow U$ are equal. Similarly, since \mathbb{W}_0 covers U , we have composed maps $\mathbb{W}_1 \rightrightarrows \mathbb{W}_0 \rightarrow U$ that are equal. This gives us a diagram

$$(6.8.4) \quad \begin{array}{ccccccc} 0 & \longrightarrow & \mathcal{M}(U) & \longrightarrow & \mathcal{M}(\mathbb{V}_0) & \xrightarrow{\beta_{\mathbb{V}}} & \mathcal{M}(\mathbb{V}_1) \\ & & \parallel & & \downarrow & & \downarrow \\ 0 & \longrightarrow & \mathcal{M}(U) & \longrightarrow & \mathcal{M}(\mathbb{W}_0) & \xrightarrow{\beta_{\mathbb{W}}} & \mathcal{M}(\mathbb{W}_1) \end{array}$$

compare-covtwo

in which $\mathcal{M}(U)$ is mapped to the kernels of $\beta_{\mathbb{V}}$ and $\beta_{\mathbb{W}}$, both of which are equal to $\mathcal{M}(V)$. Looking at the diagram, one sees that the map $\mathcal{M}(U) \rightarrow \mathcal{M}(\mathbb{W}_0)$ is the composition of the maps $\mathcal{M}(U) \rightarrow \mathcal{M}(\mathbb{V}_0) \rightarrow \mathcal{M}(\mathbb{W}_0)$. Therefore the maps $\mathcal{M}(U) \rightarrow \mathcal{M}(V)$ defined using the two coverings \mathbb{V}_0 and \mathbb{W}_0 are equal.

We show that this extended functor has the sheaf property for an affine covering $\mathbb{U}_0 = \{U^i\}$ of an affine variety U . Let \mathbb{V}_0 be a covering of U that is obtained by covering each U^i by localizations of U . This gives us a diagram

$$\begin{array}{ccccccc} 0 & \longrightarrow & \mathcal{M}(U) & \longrightarrow & \mathcal{M}(\mathbb{U}_0) & \longrightarrow & \mathcal{M}(\mathbb{U}_1) \\ & & \parallel & & \beta \downarrow & & \gamma \downarrow \\ 0 & \longrightarrow & \mathcal{M}(U) & \longrightarrow & \mathcal{M}(\mathbb{V}_0) & \longrightarrow & \mathcal{M}(\mathbb{V}_1) \end{array}$$

Because \mathbb{V}_0 covers \mathbb{U}_0 , \mathbb{V}_1 covers \mathbb{U}_1 as well. So the maps β and γ are injective. Step 1 tells us that the bottom row is exact. Then Lemma 6.3.16 (ii) shows that the top row is exact.

Step 3. (definition of $\widetilde{\mathcal{M}}$)

Let Y be an open subset of X . We use the sheaf property to define $\widetilde{\mathcal{M}}(Y)$. We choose a (finite) covering $\mathbb{U}_0 = \{U^i\}$ of Y by affine open sets, and we define $\widetilde{\mathcal{M}}(Y)$ to be the kernel $K_{\mathbb{U}}$ of the map $\mathcal{M}(\mathbb{U}_0) \xrightarrow{\beta_{\mathbb{U}}} \mathcal{M}(\mathbb{U}_1)$, where $\beta_{\mathbb{U}}$ is the map described in (6.3.10). When we show that this kernel is independent of the covering \mathbb{U}_0 , it will follow that $\widetilde{\mathcal{M}}$ is well-defined, and that it has the sheaf property.

Let $\mathbb{V}_0 = \{V^\nu\}$ be another covering of Y by affine open sets. One can go from \mathbb{U}_0 to \mathbb{V}_0 and back in a finite number of steps, each of which changes a covering by adding or deleting a single affine open set.

We consider a family $\mathbb{W}_0 = \{U^i, V\}$ obtained by adding one affine open subset V of Y to \mathbb{U}_0 , and we let \mathbb{W}_1 be the family of intersections of pairs of elements of \mathbb{W}_0 . Then with notation as above, we have a map $K_{\mathbb{W}} \rightarrow K_{\mathbb{U}}$. We show that, for any element (u_i) in the kernel $K_{\mathbb{U}}$, there is a unique element v in $\mathcal{M}(V)$ such that $((u_i), v)$ is in the kernel $K_{\mathbb{W}}$. This will show that $K_{\mathbb{W}} = K_{\mathbb{U}}$.

To define the element v , we let $V^i = U^i \cap V$. Since $\mathbb{U}_0 = \{U^i\}$ is a covering of Y , $\mathbb{V}_0 = \{V^i\}$ is a covering of V by affine open sets. Let v_i be the restriction of the section u_i to V^i . Since (u_i) is in the kernel of $\beta_{\mathbb{U}}$, $u_i = u_j$ on U^{ij} . Then it is also true that $v_i = v_j$ on the smaller open set V^{ij} . So (v_i) is in the kernel of the map $\mathcal{M}(\mathbb{V}_0) \xrightarrow{\beta_{\mathbb{V}}} \mathcal{M}(\mathbb{V}_1)$, and since \mathbb{V}_0 is a covering of the affine variety V by affine open sets, Step 2

tells us that the kernel is $\mathcal{M}(V)$. So there is a unique element v in $\mathcal{M}(V)$ that restricts to v_i on V^i for each i . We show that, with this element v , (u_i, v) is in the kernel of $\beta_{\mathbb{W}}$.

When the subsets in the family \mathbb{W}_1 are listed in the order

$$\mathbb{W}_1 = \{U^i \cap U^j\}, \{V \cap U^j\}, \{U^i \cap V\}, \{V \cap V\}$$

the map $\beta_{\mathbb{W}}$ sends $((u_i), v)$ to $((u_j - u_i), (u_j - v), (v - u_i), 0)$, restricted appropriately. Here $u_i = u_j$ on $U^i \cap U^j$ because (u_i) is in the kernel of $\beta_{\mathbb{U}}$, and $u_j = v_j = v$ on $U^j \cap V = V^j$ by definition.

##You still need to define the restriction map for arbitrary opens $V \subset U$ and verify it is compatible with scalar multiplication, as claimed in Theorem 6.3.2.##

This completes the proof of Theorem 6.3.2. □

6.9 Exercises

6.9.1. Let X be a variety. Prove that every strictly ascending chain of submodules of a finite \mathcal{O} -module \mathcal{M} is finite.

chapsix-
erc

6.9.2. Prove that a simple module over a finite type \mathbb{C} -algebra has dimension 1.

xsimple-
mod

6.9.3. Prove that if an \mathcal{O} -module has the coherence property for affine open sets U , then it has the sheaf property for affine open coverings of affine open sets.

6.9.4. Determine the sections of \mathcal{O} on the complement of a point of \mathbb{A}^2 .

6.9.5. Let \mathcal{M} and \mathcal{N} be \mathcal{O} -modules. Prove that $\text{Hom}_{\mathcal{O}}(\mathcal{M}, \mathcal{N})$ is a (quasicoherent) \mathcal{O} -module.

6.9.6. Give an example to show that the sections $\mathcal{M}(U)$ of a finite \mathcal{O} -module needn't form a finite $\mathcal{O}(U)$ -module when U isn't an affine open set.

6.9.7. Let $U' \subset U$ be affine open sets in a variety X , and let \mathcal{M} be an \mathcal{O}_X -module. Say that $\mathcal{O}(U) = A$, $\mathcal{O}(U') = A'$, $\mathcal{M}(U) = M$, and $\mathcal{M}(U') = M'$. Prove that $M' = M \otimes_A A'$.

6.9.8. Let V be the complement of a point in projective space \mathbb{P}^n . Determine $\mathcal{O}_{\mathbb{P}^n}(V)$.

regfnconst

6.9.9. Prove that, to define an \mathcal{O} -module \mathcal{M} on \mathbb{P}^1 , it is enough to give modules M_0 , M_1 , and M_{01} over the rings $\mathbb{C}[u]$, $\mathbb{C}[u^{-1}]$, and $\mathbb{C}[u, u^{-1}]$, respectively, together with isomorphisms $M_0[u^{-1}] \approx M_{01} \approx M_1[u]$.

xMze-
roMoneenuf

6.9.10. Let U be the complement of a finite set in \mathbb{P}^d . Determine $H^0(U, \mathcal{O}_U)$.

xcomplvin

6.9.11. Let s be an element of a domain A , and let M be an A -module. Prove that the limit of the directed set $M \xrightarrow{s} M \xrightarrow{s} \dots$ is isomorphic to the localization M_s .

6.9.12. Show that if \mathcal{I} and \mathcal{J} are (quasicoherent) ideals of \mathcal{O} , so is $\mathcal{I} \cap \mathcal{J}$.

6.9.13. Determine the limit of the sequence

$$\mathbb{Z} \xrightarrow{2} \mathbb{Z} \xrightarrow{2} \mathbb{Z} \xrightarrow{2} \dots,$$

where \mathbb{Z} denotes the additive group of integers, and each map is multiplication by 2.

6.9.14. Let $R = \mathbb{C}[x, y]$. Determine the limit of the directed set $R \xrightarrow{x} R \xrightarrow{x} R \xrightarrow{x} R \dots$.

limmult

6.9.15. Let $Z \xrightarrow{j} X$ be the inclusion of an open subvariety into a variety X . Prove that the functors j_* and j^* are *adjoint*: Homomorphisms of \mathcal{O}_Z -modules $j^*\mathcal{M} \rightarrow \mathcal{N}$ correspond bijectively to homomorphisms of \mathcal{O}_X -modules $\mathcal{M} \rightarrow j_*\mathcal{N}$.

6.9.16. Let \mathcal{M} be a finite \mathcal{O} -module on a variety X .

(i) Suppose that the support of \mathcal{M} is a single point p , let $M = \mathcal{M}(X)$, and let U be an affine open subset of X . Prove that, if U contains p , then $\mathcal{M}(U) = M$, and if U doesn't contain p , then $\mathcal{M}(U) = 0$.

(ii) Prove that, if the support of \mathcal{M} is a finite set $\{p_1, \dots, p_k\}$, then \mathcal{M} is the direct sum $\mathcal{M}_1 \oplus \dots \oplus \mathcal{M}_k$ of \mathcal{O} -modules supported at the points p_i .

6.9.17. Determine the degree one part of $k[x, y, z]_{z^2=xy}$, and prove that $\mathcal{O}(1)$ is not free there.

notfree

6.9.18. What are the sections of $\mathcal{O}(nH)$ on an open set V that isn't contained in any \mathbb{U}^i .

6.9.19. Describe the kernel of multiplication by a homogeneous polynomial of degree d

$$\mathcal{M}(k) \xrightarrow{f} \mathcal{M}(k+d)$$

6.9.20. Let \mathcal{M} be an \mathcal{O} -module on \mathbb{P}^n . Prove that if coordinates x of \mathbb{P}^n are in general position, multiplication by x_i defines an injective map $\mathcal{M} \rightarrow \mathcal{M}(1)$.

6.9.21. In the description (6.4.10) of modules over the projective line, we considered the standard affine open sets U^0 and U^1 . Interchanging these open sets changes the variable t to t^{-1} , and it changes the matrix P accordingly. Does it follow, when the rank is 1, that the \mathcal{O} -modules defined by t^k and by t^{-k} are isomorphic?

- xOUnotf-
nite **6.9.22.** Give an example of a finite \mathcal{O} -module \mathcal{M} and an open set U such that $\mathcal{M}(U)$ isn't a finite $\mathcal{O}(U)$ -module. Hint: The reason that this might occur is that there might not be rational functions that are regular on X , though \mathcal{M} has global sections.
- xlimM **6.9.23.** Let s be an element of a domain A , and let M be an A -module. Prove that the limit of the directed set $M \xrightarrow{s} M \xrightarrow{s} \cdots$ is isomorphic to the localization M_s .
- xmultf **6.9.24.** Describe the kernel and cokernel of multiplication by a homogeneous polynomial f of degree d :
 $\mathcal{M}(k) \xrightarrow{f} \mathcal{M}(k+d)$
- xsect-
cOnH
sectwist **6.9.25.** What are the sections of $\mathcal{O}(nH)$ on an open set V ?
- 6.9.26.** Let $X = \mathbb{P}^2$. What are the sections of the twisting module $\mathcal{O}_X(n)$ on the open complement of the line $\{x_1 + x_2 = 0\}$?
- xmultin-
ject **6.9.27.** Let M be a finite module over a finite-type domain A , and let α be a nonzero element of A . Prove that for all but finitely many complex numbers c , scalar multiplication by $s = \alpha - c$ is an injective map $M \xrightarrow{s} M$.

$$\dots \rightarrow H^q(X, \mathcal{M}) \rightarrow H^q(X, \mathcal{N}) \rightarrow H^q(X, \mathcal{P}) \xrightarrow{\delta^q} \dots$$

The maps δ^q in this sequence are the *coboundary maps*.

(b) Given a (commutative) diagram

$$\begin{array}{ccccccccc} 0 & \longrightarrow & \mathcal{M} & \longrightarrow & \mathcal{N} & \longrightarrow & \mathcal{P} & \longrightarrow & 0 \\ & & \downarrow & & \downarrow & & \downarrow & & \\ 0 & \longrightarrow & \mathcal{M}' & \longrightarrow & \mathcal{N}' & \longrightarrow & \mathcal{P}' & \longrightarrow & 0 \end{array}$$

whose rows are short exact sequences of \mathcal{O} -modules, there is a map of cohomology sequences

$$(7.1.4) \quad \begin{array}{ccccccccccc} \dots & \longrightarrow & H^q(X, \mathcal{N}) & \longrightarrow & H^q(X, \mathcal{P}) & \xrightarrow{\delta^q} & H^{q+1}(X, \mathcal{M}) & \longrightarrow & H^{q+1}(X, \mathcal{N}') & \longrightarrow & \dots \\ & & \downarrow & & \downarrow & & \downarrow & & \downarrow & & \\ \dots & \longrightarrow & H^q(X, \mathcal{N}') & \longrightarrow & H^q(X, \mathcal{P}') & \xrightarrow{\delta^q} & H^{q+1}(X, \mathcal{M}') & \longrightarrow & H^{q+1}(X, \mathcal{N}) & \longrightarrow & \dots \end{array} \quad \begin{array}{l} \text{deltadia-} \\ \text{gram} \end{array}$$

Thus a map of exact sequences of \mathcal{O} -modules induces a map of cohomology sequences.

Most of Diagram 7.1.4 arises from the fact that the H^q are functors. The only property that doesn't follow is that the squares

$$(7.1.5) \quad \begin{array}{ccc} H^q(X, \mathcal{P}) & \xrightarrow{\delta^q} & H^{q+1}(X, \mathcal{M}) \\ \downarrow & & \downarrow \\ H^q(X, \mathcal{P}') & \xrightarrow{\delta^q} & H^{q+1}(X, \mathcal{M}') \end{array} \quad \begin{array}{l} \text{deltadia-} \\ \text{gramtwo} \end{array}$$

that involve the coboundary maps δ commute.

A sequence H^q , $q = 0, 1, \dots$ of functors from \mathcal{O} -modules to vector spaces that comes with long cohomology sequences for every short exact sequence of \mathcal{O} -modules is called a *cohomological functor*.

Unfortunately, there is no natural construction of the cohomology. We present a construction in Section 7.4, but it isn't canonical. Though one needs to look at an explicit construction at times, it is usually best to work with the characteristic properties that are described below, in Section 7.3.

The cohomology in dimension one, H^1 , has an interesting interpretation that you can read about if you like. We won't use it. The cohomology in dimension greater than one has no useful direct interpretation.

7.2 Complexes

We need complexes because they are used in the construction of cohomology.

A *complex* of vector spaces is a sequence of homomorphisms of vector spaces

$$(7.2.1) \quad \dots \rightarrow V^{n-1} \xrightarrow{d^{n-1}} V^n \xrightarrow{d^n} V^{n+1} \xrightarrow{d^{n+1}} \dots \quad \begin{array}{l} \text{complex-} \\ \text{one} \end{array}$$

indexed by the integers, such that the composition $d^n d^{n-1}$ of adjacent maps is zero: the image of d^{n-1} is contained in the kernel of d^n . Such a complex may be denoted by V^\bullet .

The q -dimensional *cohomology* of a complex V^\bullet is the quotient

$$(7.2.2) \quad \mathbf{C}^q(V^\bullet) = (\ker d^q) / (\text{im } d^{q-1}). \quad \begin{array}{l} \text{cohomology} \\ \text{one} \end{array}$$

An exact sequence of vector spaces is a complex whose cohomology is zero.

A finite sequence of homomorphisms (7.2.1), $V^k \xrightarrow{d^k} V^{k+1} \rightarrow \dots \xrightarrow{d^{\ell-1}} V^\ell$, such that the compositions $d^n d^{n-1}$ are zero can be made into a complex by defining $V^n = 0$ for all other integers n . In all of the complexes in these notes, V^q will be zero when $q < 0$.

A homomorphism of vector spaces $V^0 \xrightarrow{d^0} V^1$ can be made into the complex

$$\dots \rightarrow 0 \rightarrow V^0 \xrightarrow{d^0} V^1 \rightarrow 0 \rightarrow \dots$$

For this complex, $C^0 = \ker d^0$, $C^1 = \operatorname{coker} d^0$, and $C^q = 0$ for all other q .

A map $V^\bullet \xrightarrow{\varphi} V'^\bullet$ of complexes is a collection of homomorphisms $V^n \xrightarrow{\varphi^n} V'^n$ making a diagram

$$\begin{array}{ccccccc} \longrightarrow & V^{n-1} & \xrightarrow{d^{n-1}} & V^n & \xrightarrow{d^n} & V^{n+1} & \longrightarrow \dots \\ & \varphi^{n-1} \downarrow & & \varphi^n \downarrow & & \varphi^{n+1} \downarrow & \\ \longrightarrow & V'^{n-1} & \xrightarrow{d'^{n-1}} & V'^n & \xrightarrow{d'^n} & V'^{n+1} & \longrightarrow \dots \end{array}$$

A map of complexes induces maps on the cohomology

$$C^q(V^\bullet) \rightarrow C^q(V'^\bullet)$$

because $\ker d^q$ maps to $\ker d'^q$ and $\operatorname{im} d^q$ maps to $\operatorname{im} d'^q$.

A sequence of maps of complexes

exseqcplx (7.2.3) $\dots \rightarrow V^\bullet \xrightarrow{\varphi} V'^\bullet \xrightarrow{\psi} V''^\bullet \rightarrow \dots$

is exact if the sequences

(7.2.4) $\dots \rightarrow V^q \xrightarrow{\varphi^q} V'^q \xrightarrow{\psi^q} V''^q \rightarrow \dots$

are exact for every q .

cohplx

7.2.5. Proposition.

Let $0 \rightarrow V^\bullet \rightarrow V'^\bullet \rightarrow V''^\bullet \rightarrow 0$ be a short exact sequence of complexes. For every q , there are maps $C^q(V''^\bullet) \xrightarrow{\delta^q} C^{q+1}(V^\bullet)$ such that the sequence

$$\rightarrow C^0(V^\bullet) \rightarrow C^0(V'^\bullet) \rightarrow C^0(V''^\bullet) \xrightarrow{\delta^0} C^1(V^\bullet) \rightarrow C^1(V'^\bullet) \rightarrow C^1(V''^\bullet) \xrightarrow{\delta^1} C^2(V^\bullet) \rightarrow \dots$$

is exact.

The proof of the proposition is below.

The long exact sequence is the *cohomology sequence* associated to the short exact sequence of complexes. This proposition makes the set of functors $\{C^q\}$ into a *cohomological functor* on the category of complexes.

snakeco-
homology

7.2.6. Example. We make the Snake Lemma 5.1.2 into a cohomology sequence.

Suppose given a diagram

$$\begin{array}{ccccccc} V & \xrightarrow{u} & V' & \longrightarrow & V'' & \longrightarrow & 0 \\ f \downarrow & & f' \downarrow & & f'' \downarrow & & \\ 0 & \longrightarrow & W & \longrightarrow & W' & \xrightarrow{v} & W'' \end{array}$$

with exact rows. We form the complex $0 \rightarrow V \xrightarrow{f} W \rightarrow 0$ with V in degree zero, so that $C^0(V^\bullet) = \ker f$ and $C^1(V^\bullet) = \operatorname{coker} f$, and we do the analogous thing for the maps f' and f'' . Then the Snake Lemma becomes an exact sequence

$$C^0(V^\bullet) \rightarrow C^0(V'^\bullet) \rightarrow C^0(V''^\bullet) \rightarrow C^1(V^\bullet) \rightarrow C^1(V'^\bullet) \rightarrow C^1(V''^\bullet) \quad \square$$

proof of Proposition 7.2.5. Let

$$V^\bullet = \{ \dots \rightarrow V^{q-1} \xrightarrow{d^{q-1}} V^q \xrightarrow{d^q} V^{q+1} \xrightarrow{d^{q+1}} \dots \}$$

be a complex, let B^q be the image of d^{q-1} , and let Z^q be the kernel of d^q . So $B^q \subset Z^q \subset V^q$. The cohomology of the complex V^\bullet is $\mathbf{C}^q(V^\bullet) = Z^q/B^q$. Let D^q be the cokernel V^q/B^q of d^{q-1} , so that we have an exact sequence

$$0 \rightarrow B^q \rightarrow V^q \rightarrow D^q \rightarrow 0$$

The map $V^q \xrightarrow{d^q} V^{q+1}$ factors through D^q because $B^q \subset Z^q$, and its image is in Z^{q+1} . This gives us a map $D^q \xrightarrow{f^q} Z^{q+1}$. Then d^q is the composition of three maps

$$V^q \xrightarrow{\pi^q} D^q \xrightarrow{f^q} Z^{q+1} \xrightarrow{i^{q+1}} V^{q+1}$$

where π^q is the projection from V^q to D^q and i^{q+1} is the inclusion of Z^{q+1} into V^{q+1} . Studying these maps, one sees that

$$(7.2.7) \quad \mathbf{C}^q(V^\bullet) = \ker f^q \quad \text{and} \quad \mathbf{C}^{q+1}(V^\bullet) = \operatorname{coker} f^q.$$

hiskerand-
coker

Let $0 \rightarrow V^\bullet \rightarrow V'^\bullet \rightarrow V''^\bullet \rightarrow 0$ be a short exact sequence of complexes, as in Proposition 7.2.5. In the diagram below, the rows are exact because D^q is a cokernel and cokernel is a right exact operation, and Z^q is a kernel, and kernel is left exact.

$$\begin{array}{ccccccc} D^q & \longrightarrow & D'^q & \longrightarrow & D''^q & \longrightarrow & 0 \\ f^q \downarrow & & f'^q \downarrow & & f''^q \downarrow & & \\ 0 & \longrightarrow & Z^{q+1} & \longrightarrow & Z'^{q+1} & \longrightarrow & Z''^{q+1} \end{array}$$

When we apply (7.2.7) and the Snake Lemma to this diagram, we obtain an exact sequence

$$\mathbf{C}^q(V^\bullet) \rightarrow \mathbf{C}^q(V'^\bullet) \rightarrow \mathbf{C}^q(V''^\bullet) \xrightarrow{\delta^q} \mathbf{C}^{q+1}(V^\bullet) \rightarrow \mathbf{C}^{q+1}(V'^\bullet) \rightarrow \mathbf{C}^{q+1}(V''^\bullet)$$

The cohomology sequence associated to the short exact sequence of complexes is obtained by splicing these sequences together. \square

The coboundary maps δ^q in cohomology sequences are related in a natural way. If

$$\begin{array}{ccccccc} 0 & \longrightarrow & U^\bullet & \longrightarrow & U'^\bullet & \longrightarrow & U''^\bullet \longrightarrow 0 \\ & & \downarrow & & \downarrow & & \downarrow \\ 0 & \longrightarrow & V^\bullet & \longrightarrow & V'^\bullet & \longrightarrow & V''^\bullet \longrightarrow 0 \end{array}$$

is a diagram of maps of complexes whose rows are short exact sequences, the diagrams

$$\begin{array}{ccc} \mathbf{C}^q(U''^\bullet) & \xrightarrow{\delta^q} & \mathbf{C}^{q+1}(U^\bullet) \\ \downarrow & & \downarrow \\ \mathbf{C}^q(V''^\bullet) & \xrightarrow{\delta^q} & \mathbf{C}^{q+1}(V^\bullet) \end{array}$$

commute. It isn't difficult to check this. Thus a map of short exact sequences induces a map of cohomology sequences.

7.3 Characteristic Properties of Cohomology

charprop

The cohomology $H^q(X, \cdot)$ of \mathcal{O} -modules, the sequence of functors H^0, H^1, H^2, \dots from *mod* to (*vector spaces*), is characterized by the three properties below. The first two have already been mentioned.

charpro-
pone

(7.3.1) Characteristic Properties

1. $H^0(X, \mathcal{M})$ is the space $\mathcal{M}(X)$ of global sections of \mathcal{M} .
2. The sequence H^0, H^1, H^2, \dots is a cohomological functor on \mathcal{O} -modules: A short exact sequence of \mathcal{O} -modules produces a long exact cohomology sequence.
3. Let $Y \xrightarrow{f} X$ be the inclusion of an *affine* open subset Y into X , let \mathcal{N} be an \mathcal{O}_Y -module, and let $f_*\mathcal{N}$ be its direct image on X . The cohomology $H^q(X, f_*\mathcal{N})$ is zero for all $q > 0$.

When Y is an affine variety, the global section functor is exact: If $0 \rightarrow \mathcal{M} \rightarrow \mathcal{N} \rightarrow \mathcal{P} \rightarrow 0$ is a short exact sequence of \mathcal{O} -modules on Y , the sequence

$$0 \rightarrow H^0(Y, \mathcal{M}) \rightarrow H^0(Y, \mathcal{N}) \rightarrow H^0(Y, \mathcal{P}) \rightarrow 0$$

is exact. There is no need for the higher cohomology H^q . One may as well define $H^q(Y, \cdot) = 0$ when Y is affine and $q > 0$. The third characteristic property is based on this observation.

Intuitively, the third property tells us that allowing poles on the complement of an affine open set kills cohomology in positive safension.

existco-
hom

7.3.2. Theorem. *There exists a cohomology theory with the properties (7.3.1), and it is unique up to unique isomorphism.*

The proof is in the next section.

cozco-
roaffine

7.3.3. Corollary. *If X is an affine variety, $H^q(X, \mathcal{M}) = 0$ for all \mathcal{O} -modules \mathcal{M} and all $q > 0$.*

This follows when one applies the third characteristic property to the identity map $X \rightarrow X$. □

7.3.4. Example. Let j be the inclusion of the standard affine open set \mathbb{U}^0 into projective space X . The third property tells us that the cohomology $H^q(X, j_*\mathcal{O}_{\mathbb{U}^0})$ of the direct image $j_*\mathcal{O}_{\mathbb{U}^0}$ is zero when $q > 0$. The direct image is isomorphic to the limit $\varinjlim \mathcal{O}_X(nH)$ (6.7.13). We will see below (7.4.26) that cohomology commutes with direct limits. Therefore $\varinjlim H^q(X, \mathcal{O}_X(nH))$ and $\varinjlim H^q(X, \mathcal{O}_X(n))$ are zero when $q > 0$. This will be useful. □

cohdirmsum

7.3.5. Lemma. *Let \mathcal{M} and \mathcal{N} be \mathcal{O} -modules on a variety X . The cohomology $H^q(X, \mathcal{M} \oplus \mathcal{N})$ of the direct sum is $\mathcal{M} \oplus \mathcal{N}$ is canonically isomorphic to the direct sum $H^q(X, \mathcal{M}) \oplus H^q(X, \mathcal{N})$.*

In this statement, one could substitute e just about any functor for H^q .

proof. We have homomorphisms of \mathcal{O} -modules $\mathcal{M} \xrightarrow{i_1} \mathcal{M} \oplus \mathcal{N} \xrightarrow{\pi_1} \mathcal{M}$ and analogous homomorphisms $\mathcal{N} \xrightarrow{i_2} \mathcal{M} \oplus \mathcal{N} \xrightarrow{\pi_2} \mathcal{N}$, where i_1, i_2 are the inclusions and π_1, π_2 are the projections. It is an exercise to show that the direct sum can be characterized by these maps, together with the relations $\pi_1 i_1 = id_{\mathcal{M}}, \pi_2 i_2 = id_{\mathcal{N}}, \pi_2 i_1 = 0, \pi_1 i_2 = 0$, and $i_1 \pi_1 + i_2 \pi_2 = id_{\mathcal{M} \oplus \mathcal{N}}$. Applying the functor H^q , gives analogous homomorphisms relating $H^q(\mathcal{M}), H^q(\mathcal{N})$, and $H^q(\mathcal{M} \oplus \mathcal{N})$. □

7.4 Existence of Cohomology

constrcoh

The proof of existence of cohomology and its uniqueness are based on the following facts:

- The intersection of two affine open subsets of a variety is an affine open set. (This is Theorem 3.6.8.)
- A sequence $\dots \rightarrow \mathcal{M} \rightarrow \mathcal{N} \rightarrow \mathcal{P} \rightarrow \dots$ of \mathcal{O} -modules on a variety X is exact if and only if, for every affine open subset U , the sequence of sections $\dots \rightarrow \mathcal{M}(U) \rightarrow \mathcal{N}(U) \rightarrow \mathcal{P}(U) \rightarrow \dots$ is exact. (This is the definition of exactness.)

We begin by choosing an arbitrary affine covering $\mathbb{U} = \{U^\nu\}$ of our variety X by finitely many affine open sets U^ν , and we use this covering to describe the cohomology. When we have shown that cohomology is unique, we will know that it is independent of our choice of covering.

Let $\mathbb{U} \xrightarrow{j} X$ denote the inclusions $U^\nu \xrightarrow{j^\nu} X$ of our chosen affine open sets into X . If \mathcal{M} is an \mathcal{O} -module, $\mathcal{R}_{\mathcal{M}}$ will denote the \mathcal{O} -module $j_*\mathcal{M}_{\mathbb{U}} = \prod j_*\mathcal{M}_{U^\nu}$, where \mathcal{M}_{U^ν} is the restriction of \mathcal{M} to U^ν . As has been noted, there is a canonical map $\mathcal{M} \rightarrow j_*\mathcal{M}_{U^\nu}$, and therefore a canonical map $\mathcal{M} \rightarrow \mathcal{R}_{\mathcal{M}}$ (6.5.9).

7.4.1. Lemma. (i) Let X' be an open subset of X . The module of sections $\mathcal{R}_{\mathcal{M}}(X')$ of $\mathcal{R}_{\mathcal{M}}$ on X' is the product $\prod_{\nu} \mathcal{M}(X' \cap U^{\nu})$. In particular, the space of global sections $\mathcal{R}_{\mathcal{M}}(X)$, which is $H^0(X, \mathcal{R}_{\mathcal{M}})$, is the product $\prod_{\nu} \mathcal{M}(U^{\nu})$.

defcalr

(ii) The canonical map $\mathcal{M} \rightarrow \mathcal{R}_{\mathcal{M}}$ is injective. Thus, if $\mathcal{S}_{\mathcal{M}}$ denotes the cokernel of that map, there is a short exact sequence of \mathcal{O} -modules

$$(7.4.2) \quad 0 \rightarrow \mathcal{M} \rightarrow \mathcal{R}_{\mathcal{M}} \rightarrow \mathcal{S}_{\mathcal{M}} \rightarrow 0$$

MRzeroMone

(iii) For any cohomology theory with the characteristic properties and for any $q > 0$, $H^q(X, \mathcal{R}_{\mathcal{M}}) = 0$.

proof. **(i)** This is seen by going through the definitions:

$$\mathcal{R}(X') = \prod_{\nu} [j_{\nu*} \mathcal{M}_{U^{\nu}}](X') = \prod_{\nu} \mathcal{M}_{U^{\nu}}(X' \cap U^{\nu}) = \prod_{\nu} \mathcal{M}(X' \cap U^{\nu}).$$

(ii) Let X' be an open subset of X . The map $\mathcal{M}(X') \rightarrow \mathcal{R}_{\mathcal{M}}(X')$ is the product of the restriction maps $\mathcal{M}(X') \rightarrow \mathcal{M}(X' \cap U^{\nu})$. Because the open sets U^{ν} cover X , the intersections $X' \cap U^{\nu}$ cover X' . The sheaf property of \mathcal{M} tells us that the map $\mathcal{M}(X') \rightarrow \prod_{\nu} \mathcal{M}(X' \cap U^{\nu})$ is injective.

(iii) This follows from the third characteristic property. □

7.4.3. Lemma. (i) A short exact sequence $0 \rightarrow \mathcal{M} \rightarrow \mathcal{N} \rightarrow \mathcal{P} \rightarrow 0$ of \mathcal{O} -modules embeds into a diagram

Rcminjective

$$(7.4.4) \quad \begin{array}{ccccc} \mathcal{M} & \longrightarrow & \mathcal{N} & \longrightarrow & \mathcal{P} \\ \downarrow & & \downarrow & & \downarrow \\ \mathcal{R}_{\mathcal{M}} & \longrightarrow & \mathcal{R}_{\mathcal{N}} & \longrightarrow & \mathcal{R}_{\mathcal{P}} \\ \downarrow & & \downarrow & & \downarrow \\ \mathcal{S}_{\mathcal{M}} & \longrightarrow & \mathcal{S}_{\mathcal{N}} & \longrightarrow & \mathcal{S}_{\mathcal{P}} \end{array}$$

ttdiagr

whose rows and columns are short exact sequences. (We have suppressed the surrounding zeros.)

(ii) The sequence of global sections $0 \rightarrow \mathcal{R}_{\mathcal{M}}(X) \rightarrow \mathcal{R}_{\mathcal{N}}(X) \rightarrow \mathcal{R}_{\mathcal{P}}(X) \rightarrow 0$ is exact.

proof. **(i)** We are given that the top row of the diagram is a short exact sequence, and we have seen that the columns are short exact sequences. To show that the middle row

$$(7.4.5) \quad 0 \rightarrow \mathcal{R}_{\mathcal{M}} \rightarrow \mathcal{R}_{\mathcal{N}} \rightarrow \mathcal{R}_{\mathcal{P}} \rightarrow 0$$

Rsequence

is exact, we must show that if X' is an affine open subset, the sections on X' form a short exact sequence. The sections are explained in Lemma 7.4.1 **(i)**. Since products of exact sequences are exact, we must show that the sequence

$$0 \rightarrow \mathcal{M}(X' \cap U^{\nu}) \rightarrow \mathcal{N}(X' \cap U^{\nu}) \rightarrow \mathcal{P}(X' \cap U^{\nu}) \rightarrow 0$$

is exact. This is true because $X' \cap U^{\nu}$ is an intersection of affine opens, and is therefore affine.

Now that we know that the first two rows of the diagram are short exact sequences, the Snake Lemma applied to the top two rows of the diagram tells us that the bottom row is a short exact sequence.

(ii) The sequence of global sections is the product of the sequences

$$0 \rightarrow \mathcal{M}(U^{\nu}) \rightarrow \mathcal{N}(U^{\nu}) \rightarrow \mathcal{P}(U^{\nu}) \rightarrow 0$$

These sequences are exact because the open sets U^{ν} are affine. □

(7.4.6) uniqueness of cohomology

uniquecoh

Suppose that a cohomology with the characteristic properties (7.3.1) is given, and let \mathcal{M} be an \mathcal{O} -module. The cohomology sequence associated to the sequence $0 \rightarrow \mathcal{M} \rightarrow \mathcal{R}_{\mathcal{M}} \rightarrow \mathcal{S}_{\mathcal{M}} \rightarrow 0$ is

$$0 \rightarrow H^0(X, \mathcal{M}) \rightarrow H^0(X, \mathcal{R}_{\mathcal{M}}) \rightarrow H^0(X, \mathcal{S}_{\mathcal{M}}) \xrightarrow{\delta^0} H^1(X, \mathcal{M}) \rightarrow H^1(X, \mathcal{R}_{\mathcal{M}}) \rightarrow \cdots$$

Lemma 7.4.1 (iii) tells us that $H^q(X, \mathcal{R}_M) = 0$ when $q > 0$. So this cohomology sequence breaks up into an exact sequence

$$(7.4.7) \quad 0 \rightarrow H^0(X, \mathcal{M}) \rightarrow H^0(X, \mathcal{R}_M) \rightarrow H^0(X, \mathcal{S}_M) \xrightarrow{\delta^0} H^1(X, \mathcal{M}) \rightarrow 0$$

and isomorphisms for every $q > 0$

$$(7.4.8) \quad 0 \rightarrow H^q(X, \mathcal{S}_M) \xrightarrow{\delta^q} H^{q+1}(X, \mathcal{M}) \rightarrow 0$$

for every $q > 0$. The first three terms of the sequence (7.4.7), and the arrows connecting them, depend on our choice of covering of X , but the important point is that they don't depend on the cohomology. So that sequence determines $H^1(X, \mathcal{M})$ up to unique isomorphism as the cokernel of a map that is independent of the cohomology, and this is true for every \mathcal{O} -module \mathcal{M} , including for the module \mathcal{S}_M . Therefore it is also true that $H^1(X, \mathcal{S}_M)$ is determined uniquely. This being so, $H^2(X, \mathcal{M})$ is determined uniquely for every \mathcal{M} , by the isomorphism (7.4.8), with $q = 1$. The isomorphisms (7.4.8) determine the rest of the cohomology up to unique isomorphism by induction on q . \square

existcohom (7.4.9) construction of cohomology

One can use the sequence (7.4.2) and induction to construct cohomology, but it seems clearer to proceed by iterating the construction of \mathcal{R}_M .

Let \mathcal{M} be an \mathcal{O} -module. We rewrite the exact sequence (7.4.2), labeling \mathcal{R}_M as \mathcal{R}_M^0 , and \mathcal{S}_M as \mathcal{M}^1 :

$$(7.4.10) \quad 0 \rightarrow \mathcal{M} \rightarrow \mathcal{R}_M^0 \rightarrow \mathcal{M}^1 \rightarrow 0$$

and we repeat the construction with \mathcal{M}^1 . Let $\mathcal{R}_M^1 = \mathcal{R}_{\mathcal{M}^1}^0 (= j_* \mathcal{M}_{\mathbb{U}}^1)$, so that there is an exact sequence

$$(7.4.11) \quad 0 \rightarrow \mathcal{M}^1 \rightarrow \mathcal{R}_M^1 \rightarrow \mathcal{M}^2 \rightarrow 0$$

analogous to the sequence (7.4.10), with $\mathcal{M}^2 = \mathcal{R}_{\mathcal{M}^1}^1 / \mathcal{M}^1$. We combine the sequences (7.4.10) and (7.4.11) into an exact sequence

$$(7.4.12) \quad 0 \rightarrow \mathcal{M} \rightarrow \mathcal{R}_M^0 \rightarrow \mathcal{R}_M^1 \rightarrow \mathcal{M}^2 \rightarrow 0$$

Then we let $\mathcal{R}_M^2 = \mathcal{R}_{\mathcal{M}^2}^0$. We continue in this way, to construct modules \mathcal{R}_M^k that form an exact sequence

$$(7.4.13) \quad 0 \rightarrow \mathcal{M} \rightarrow \mathcal{R}_M^0 \rightarrow \mathcal{R}_M^1 \rightarrow \mathcal{R}_M^2 \rightarrow \dots$$

The next lemma follows by induction from Lemmas 7.4.1 and 7.4.3.

Rcmexact 7.4.14. Lemma.

(i) Let $0 \rightarrow \mathcal{M} \rightarrow \mathcal{N} \rightarrow \mathcal{P} \rightarrow 0$ be a short exact sequence of \mathcal{O} -modules. For every n , the sequences

$$0 \rightarrow \mathcal{R}_M^n \rightarrow \mathcal{R}_N^n \rightarrow \mathcal{R}_P^n \rightarrow 0$$

are exact, and so are the sequences of global sections

$$0 \rightarrow \mathcal{R}_M^n(X) \rightarrow \mathcal{R}_N^n(X) \rightarrow \mathcal{R}_P^n(X) \rightarrow 0$$

(ii) If H^0, H^1, \dots is a cohomology theory, then $H^q(X, \mathcal{R}_M^n) = 0$ for all n and all $q > 0$. \square

An exact sequence such as (7.4.13) is called a *resolution* of \mathcal{M} , and because $H^q(X, \mathcal{R}_M^n) = 0$ when $q > 0$, it is an *acyclic resolution* of \mathcal{M} .

Continuing with the proof of existence, we consider the complex of \mathcal{O} -modules $\mathcal{R}_{\mathcal{M}}^{\bullet}$ that is obtained by omitting the first term from (7.4.13):

$$(7.4.15) \quad 0 \rightarrow \mathcal{R}_{\mathcal{M}}^0 \rightarrow \mathcal{R}_{\mathcal{M}}^1 \rightarrow \mathcal{R}_{\mathcal{M}}^2 \rightarrow \dots$$

and the complex $\mathcal{R}_{\mathcal{M}}^{\bullet}(X)$ of its global sections:

$$(7.4.16) \quad 0 \rightarrow \mathcal{R}_{\mathcal{M}}^0(X) \rightarrow \mathcal{R}_{\mathcal{M}}^1(X) \rightarrow \mathcal{R}_{\mathcal{M}}^2(X) \rightarrow \dots$$

which we can also write as

$$0 \rightarrow H^0(X, \mathcal{R}_{\mathcal{M}}^0) \rightarrow H^0(X, \mathcal{R}_{\mathcal{M}}^1) \rightarrow H^0(X, \mathcal{R}_{\mathcal{M}}^2) \rightarrow \dots$$

The sequence $\mathcal{R}_{\mathcal{M}}^{\bullet}$ becomes the resolution (7.4.13) when the module \mathcal{M} is inserted. So the complex (7.4.15) is exact except at $\mathcal{R}_{\mathcal{M}}^0$. But the sequence (7.4.16) of global sections $\mathcal{R}_{\mathcal{M}}^{\bullet}(X)$ needn't be exact anywhere. The global section functor is only left exact. However, the sequence of global sections is a complex because $\mathcal{R}_{\mathcal{M}}^{\bullet}$ is a complex. The composition of adjacent maps is zero.

Recall that the cohomology of a complex $0 \rightarrow V^0 \xrightarrow{d^0} V^1 \xrightarrow{d^1} \dots$ of vector spaces is defined to be $\mathbf{C}^q(V^{\bullet}) = (\ker d^q)/(\text{im } d^{q-1})$, and that $\{\mathbf{C}^q\}$ is a cohomological functor on complexes (7.2.5).

7.4.17. Definition. The cohomology of an \mathcal{O} -module \mathcal{M} is the cohomology of the complex $\mathcal{R}_{\mathcal{M}}^{\bullet}(X)$:

$$H^q(X, \mathcal{M}) = \mathbf{C}^q(\mathcal{R}_{\mathcal{M}}^{\bullet}(X))$$

Thus if we denote the maps in the complex (7.4.16) by d^q ,

$$0 \rightarrow \mathcal{R}_{\mathcal{M}}^0(X) \xrightarrow{d^0} \mathcal{R}_{\mathcal{M}}^1(X) \xrightarrow{d^1} \mathcal{R}_{\mathcal{M}}^2(X) \rightarrow \dots$$

then $H^q(X, \mathcal{M}) = (\ker d^q)/(\text{im } d^{q-1})$.

7.4.18. Lemma. Let X be an affine variety. With cohomology defined as above, $H^q(X, \mathcal{M}) = 0$ for all \mathcal{O} -modules \mathcal{M} and all $q > 0$.

proof. When X is affine, the sequence of global sections of the exact sequence (7.4.13) is exact. \square

To show that our definition gives the (unique) cohomology, we verify the three characteristic properties. Since the sequence (7.4.13) is exact and since the global section functor is left exact, $\mathcal{M}(X)$ is the kernel of the map $\mathcal{R}_{\mathcal{M}}^0(X) \rightarrow \mathcal{R}_{\mathcal{M}}^1(X)$, and this kernel is also equal to $\mathbf{C}^0(\mathcal{R}_{\mathcal{M}}^{\bullet}(X))$. So our cohomology has the first property: $H^0(X, \mathcal{M}) = \mathcal{M}(X)$.

To show that we obtain a cohomological functor, we apply Lemma 7.4.14 to conclude that, for a short exact sequence $0 \rightarrow \mathcal{M} \rightarrow \mathcal{N} \rightarrow \mathcal{P} \rightarrow 0$, the spaces of global sections

$$(7.4.19) \quad 0 \rightarrow \mathcal{R}_{\mathcal{M}}^{\bullet}(X) \rightarrow \mathcal{R}_{\mathcal{N}}^{\bullet}(X) \rightarrow \mathcal{R}_{\mathcal{P}}^{\bullet}(X) \rightarrow 0,$$

form an exact sequence of complexes. The cohomology $H^q(X, \cdot)$ is a cohomological functor because cohomology of complexes is a cohomological functor. This is the second characteristic property.

We make a digression before verifying the third characteristic property.

(7.4.20) affine morphisms

Let $Y \xrightarrow{f} X$ be a morphism of varieties. Let $U \xrightarrow{j} X$ be the inclusion of an open subvariety into X and let V be the inverse image $f^{-1}U$, which is an open subvariety of Y . These varieties and maps form a diagram

$$(7.4.21) \quad \begin{array}{ccc} V & \xrightarrow{i} & Y \\ g \downarrow & & \downarrow f \\ U & \xrightarrow{j} & X \end{array}$$

As before, the notation \mathcal{M}_U stands for the restriction of \mathcal{M} to the open subset U .

With notation as in the diagram above, let \mathcal{N} be an \mathcal{O}_Y -module. When we restrict the direct image $f_*\mathcal{N}$ of \mathcal{N} to U , we obtain an \mathcal{O}_U -module $[f_*\mathcal{N}]_U$. We can obtain an \mathcal{O}_U -module in a second way: First restrict the module \mathcal{N} to the open subset V of Y , and then take its direct image. We obtain the \mathcal{O}_U -module $g_*[\mathcal{N}_V]$.

jstarfs-
tartwo

7.4.22. Lemma. *The \mathcal{O}_U -modules $g_*[\mathcal{N}_V]$ and $[f_*\mathcal{N}]_U$ are the same.*

proof. Let U' be an open subset of U , and let $V' = g^{-1}U'$. Then

$$[f_*\mathcal{N}]_U(U') = [f_*\mathcal{N}](U') = \mathcal{N}(V') = \mathcal{N}_V(V') = [g_*[\mathcal{N}_V]](U') \quad \square$$

de-
faffmorph

7.4.23. Definition. An *affine morphism* is a morphism $Y \xrightarrow{f} X$ of varieties with the property that the inverse image $f^{-1}(U)$ of every affine open subset U of X is an affine open subset of Y . \square

The following are examples of affine morphisms:

- the inclusion of an affine open subset Y into X ,
- the inclusion of a closed subvariety Y into X ,
- a finite morphism, or an integral morphism.

But, the inclusion of a non-affine open set may not be an affine morphism. For example, let Y be the complement of a point of the projective plane X . The inclusion $Y \rightarrow X$ isn't an affine morphism.

fs-
taraffmorph

7.4.24. Lemma. *Let $Y \xrightarrow{f} C$ be an affine morphism and let $\mathcal{N} \rightarrow \mathcal{N}' \rightarrow \mathcal{N}''$ be an exact sequence of \mathcal{O}_Y -modules. The sequence of direct images $f_*\mathcal{N} \rightarrow f_*\mathcal{N}' \rightarrow f_*\mathcal{N}''$ is exact.* \square

Let $Y \xrightarrow{f} X$ be an affine morphism, let j be the map from our chosen affine covering $\mathbb{U} = \{U^\nu\}$ to X , and let \mathbb{V} denote the family $\{V^\nu\} = \{f^{-1}U^\nu\}$ of inverse images. Then \mathbb{V} is an affine covering of Y , and there is a morphism $\mathbb{V} \xrightarrow{g} \mathbb{U}$. We form a diagram analogous to (7.4.21), in which \mathbb{V} and \mathbb{U} replace V and U , respectively:

$$\begin{array}{ccc} \mathbb{V} & \xrightarrow{i} & Y \\ g \downarrow & & f \downarrow \\ \mathbb{U} & \xrightarrow{j} & X \end{array}$$

affinedi-
rectimage

7.4.25. Proposition. *Let $Y \xrightarrow{f} X$ be an affine morphism, and let \mathcal{N} be an \mathcal{O}_Y -module. Let $H^q(X, \cdot)$ be cohomology defined in (7.4.17), and let $H^q(Y, \cdot)$ be cohomology defined in the analogous way, using the covering \mathbb{V} of Y . Then $H^q(X, f_*\mathcal{N})$ is isomorphic to $H^q(Y, \mathcal{N})$.*

proof. This proof is easy, once one has untangled the notation.

To compute the cohomology of $f_*\mathcal{N}$ on X , we substitute $\mathcal{M} = f_*\mathcal{N}$ into (7.4.17):

$$H^q(X, f_*\mathcal{N}) = \mathbf{C}^q(\mathcal{R}_{f_*\mathcal{N}}^\bullet(X)).$$

To compute the cohomology of \mathcal{N} on Y , we let

$$\mathcal{R}'_{\mathcal{N}}{}^0 = i_*[\mathcal{N}_V]$$

and we continue, to construct a resolution $\mathcal{R}'_{\mathcal{N}}{}^\bullet = 0 \rightarrow \mathcal{N} \rightarrow \mathcal{R}'_{\mathcal{N}}{}^0 \rightarrow \mathcal{R}'_{\mathcal{N}}{}^1 \rightarrow \cdots$ and the complex of its global sections $\mathcal{R}'_{\mathcal{N}}{}^\bullet(Y)$. (The prime is there to remind us that \mathcal{R}' is defined using the covering \mathbb{V} of Y .) Then

$$H^q(Y, \mathcal{N}) = \mathbf{C}^q(\mathcal{R}'_{\mathcal{N}}{}^\bullet(Y)).$$

It suffices to show that the complexes $\mathcal{R}_{f_*\mathcal{N}}^\bullet(X)$ and $\mathcal{R}'_{\mathcal{N}}{}^\bullet(Y)$ are isomorphic. If so, we will have

$$H^q(X, f_*\mathcal{N}) = \mathbf{C}^q(\mathcal{R}_{f_*\mathcal{N}}^\bullet(X)) \approx \mathbf{C}^q(\mathcal{R}'_{\mathcal{N}}{}^\bullet(Y)) = H^q(Y, \mathcal{N})$$

as required.

By definition of the direct image, $[f_*\mathcal{R}'_{\mathcal{N}}{}^q](X) = \mathcal{R}'_{\mathcal{N}}{}^q(Y)$. So we must show that $\mathcal{R}_{f_*\mathcal{N}}^q(X) \approx f_*\mathcal{R}'_{\mathcal{N}}{}^q(X)$, and it suffices to show that $\mathcal{R}_{f_*\mathcal{N}}^q \approx f_*\mathcal{R}'_{\mathcal{N}}{}^q$. We look back at the definition (7.4.11) of the modules \mathcal{R}^0 in its rewritten form (7.4.10). On Y , the analogous sequence for \mathcal{N} is

$$0 \rightarrow \mathcal{N} \rightarrow \mathcal{R}'_{\mathcal{N}}{}^0 \rightarrow \mathcal{N}^1 \rightarrow 0$$

where $\mathcal{R}'_{\mathcal{N}} = i_*\mathcal{N}_{\mathbb{V}}$. When f is an affine morphism, the direct image of this sequence is exact:

$$0 \rightarrow f_*\mathcal{N} \rightarrow f_*\mathcal{R}'_{\mathcal{N}} \rightarrow f_*\mathcal{N}^1 \rightarrow 0$$

Here

$$f_*\mathcal{R}'_{\mathcal{N}} = f_*i_*\mathcal{N}_{\mathbb{V}} = j_*g_*\mathcal{N}_{\mathbb{V}} = j_*[f_*\mathcal{N}]_{\mathbb{U}} = \mathcal{R}_{f_*\mathcal{N}}^0$$

The third equality is Lemma 7.4.22.

So $f_*\mathcal{R}'_{\mathcal{N}} = \mathcal{R}_{f_*\mathcal{N}}^0$. Now induction on q applies. \square

We go back to the proof of existence of cohomology to verify the third characteristic property, which is that when $Y \xrightarrow{f} X$ is the inclusion of an affine open subset, $H^q(X, f_*\mathcal{N}) = 0$ for all \mathcal{O}_Y -modules \mathcal{N} and all $q > 0$. The inclusion of an affine open set is an affine morphism, so $H^q(Y, \mathcal{N}) = H^q(X, f_*\mathcal{N})$ (7.4.25), and since Y is affine, $H^q(Y, \mathcal{N}) = 0$ for all $q > 0$ (7.4.18). \square

Proposition 7.4.25 is one of the places where a specific construction of cohomology is used. The characteristic properties don't apply directly. The next proposition is another such place.

7.4.26. Lemma. *Cohomology is compatible with limits of directed sets of \mathcal{O} -modules: $H^q(X, \varinjlim \mathcal{M}_{\bullet}) \approx \varinjlim H^q(X, \mathcal{M}_{\bullet})$ for all q .* cohlimit

proof. The direct and inverse image functors and the global section functor are all compatible with \varinjlim , and \varinjlim is exact (6.4.23). So the module $\mathcal{R}_{\varinjlim \mathcal{M}_{\bullet}}^q$ that is used to compute the cohomology of $\varinjlim \mathcal{M}_{\bullet}$ is isomorphic to $\varinjlim [\mathcal{R}_{\mathcal{M}_{\bullet}}^q]$, and $\mathcal{R}_{\varinjlim \mathcal{M}_{\bullet}}^q(X)$ is isomorphic to $\varinjlim [\mathcal{R}_{\mathcal{M}_{\bullet}}^q](X)$. \square

(7.4.27) uniqueness of the coboundary maps

unique-cobound

We have constructed a cohomology $\{H^q\}$ that has the characteristic properties, and we have shown that the functors H^q are unique. We haven't shown that the coboundary maps δ^q that appear in the cohomology sequences are unique. To make it clear that there is something to show, we note that the cohomology sequence (7.1.3) remains exact when some of the coboundary maps δ^q are multiplied by -1 . Why can't we define a new collection of coboundary maps by changing some signs? The reason we can't do this is that we used the coboundary maps δ^q in (7.4.7) and (7.4.8), to identify $H^q(X, \mathcal{M})$. Having done that, we aren't allowed to change δ^q for the particular short exact sequences (7.4.2). We show that the coboundary maps for those sequences determine the coboundary maps for every short exact sequence of \mathcal{O} -modules

$$(A) \quad 0 \rightarrow \mathcal{M} \rightarrow \mathcal{N} \rightarrow \mathcal{P} \rightarrow 0$$

The sequences (7.4.2) were rewritten as (7.4.10). We will use that form.

To show that the coboundaries for the sequence (A) are determined uniquely, we relate it to a sequence for which the coboundary maps are fixed:

$$(B) \quad 0 \rightarrow \mathcal{M} \rightarrow \mathcal{R}_{\mathcal{M}}^0 \rightarrow \mathcal{M}^1 \rightarrow 0$$

We map (A) and (B) to a third short exact sequence

$$(C) \quad 0 \rightarrow \mathcal{M} \xrightarrow{\psi} \mathcal{R}_{\mathcal{N}}^0 \rightarrow \mathcal{Q} \rightarrow 0$$

where ψ is the composition of the injective maps $\mathcal{M} \rightarrow \mathcal{N} \rightarrow \mathcal{R}_{\mathcal{N}}^0$ and \mathcal{Q} is the cokernel of ψ .

First, we inspect the diagram

$$\begin{array}{ccccc} (A) & \mathcal{M} & \longrightarrow & \mathcal{N} & \longrightarrow & \mathcal{P} \\ & \parallel & & \downarrow & & \downarrow \\ (C) & \mathcal{M} & \xrightarrow{\psi} & \mathcal{R}_{\mathcal{N}}^0 & \longrightarrow & \mathcal{Q} \end{array}$$

and its diagram of coboundary maps

$$(A) \quad \begin{array}{ccc} H^q(X, \mathcal{P}) & \xrightarrow{\delta_A^q} & H^{q+1}(X, \mathcal{M}) \\ \downarrow & & \parallel \\ (C) \quad H^q(X, \mathcal{Q}) & \xrightarrow{\delta_C^q} & H^{q+1}(X, \mathcal{M}) \end{array}$$

This diagram shows that the coboundary map δ_A^q for the sequence (A) is determined by the coboundary map δ_C^q for (C).

Next, we inspect the diagram

BtoC (7.4.28)
$$(B) \quad \begin{array}{ccccc} \mathcal{M} & \longrightarrow & \mathcal{R}_{\mathcal{M}}^0 & \longrightarrow & \mathcal{M}^1 \\ & & \parallel & & \downarrow v \\ (C) \quad \mathcal{M} & \xrightarrow{\psi} & \mathcal{R}_{\mathcal{N}}^0 & \longrightarrow & \mathcal{Q} \end{array}$$

and its diagram of coboundary maps

$$(B) \quad \begin{array}{ccc} H^q(X, \mathcal{M}^1) & \xrightarrow{\delta_B^q} & H^{q+1}(X, \mathcal{M}) \\ \downarrow & & \parallel \\ (C) \quad H^q(X, \mathcal{Q}) & \xrightarrow{\delta_C^q} & H^{q+1}(X, \mathcal{M}) \end{array}$$

When $q > 0$, δ_C^q and δ_B^q are bijective because the cohomology of $\mathcal{R}_{\mathcal{M}}^0$ and $\mathcal{R}_{\mathcal{N}}^0$ is zero in positive dimension. Then δ_C^q is uniquely determined by δ_B^q , and so is δ_A^q .

We have to look more closely to settle the case $q = 0$. The map labeled u in (7.4.28) is injective, and the Snake Lemma shows that v is injective. The cokernels of u and v are isomorphic. We write both of the cokernels as $\mathcal{R}_{\mathcal{P}}^0$. When we add the cokernels to the diagram, and pass to cohomology, we obtain a diagram whose relevant part is

$$(B) \quad \begin{array}{ccccc} H^0(X, \mathcal{R}_{\mathcal{M}}^0) & \longrightarrow & H^0(X, \mathcal{M}^1) & \xrightarrow{\delta_B^0} & H^1(X, \mathcal{M}) \\ u \downarrow & & \downarrow v & & \parallel \\ (C) \quad H^0(X, \mathcal{R}_{\mathcal{N}}^0) & \xrightarrow{\beta} & H^0(X, \mathcal{Q}) & \xrightarrow{\delta_C^0} & H^1(X, \mathcal{M}) \\ \downarrow \gamma & & \downarrow & & \\ H^0(X, \mathcal{R}_{\mathcal{P}}^0) & \xlongequal{\quad} & H^0(X, \mathcal{R}_{\mathcal{P}}^0) & & \end{array}$$

The rows and columns in the diagram are exact. We want to show that the map δ_C^0 is determined uniquely by δ_B^0 . It is determined by δ_B^0 on the image of v and it is zero on the image of β . To show that δ_C^0 is determined by δ_B^0 , it suffices to show that the images of v and β together span $H^0(X, \mathcal{Q})$. This follows from the fact that γ is surjective. Thus δ_C^0 is determined uniquely by δ_B^0 , and so is δ_A^0 . \square

7.5 Cohomology of the Twisting Modules

cohprojsp

We determine the cohomology of the twisting modules $\mathcal{O}(d)$ on \mathbb{P}^n here. As we will see, $H^q(\mathbb{P}^n, \mathcal{O}(d))$ is zero for most values of q . This will help us to determine the cohomology of other modules.

Lemma 7.4.18 about vanishing of cohomology on an affine variety, and Lemma 7.4.25 about the direct image via an affine morphism, were stated using a particular affine covering. Since we know that cohomology is unique, that particular covering is irrelevant. Though it isn't necessary, we restate those lemmas here as a corollary:

affineco-
hzerotwo

7.5.1. Corollary. (i) *On an affine variety X , $H^q(X, \mathcal{M}) = 0$ for all \mathcal{O} -modules \mathcal{M} and all $q > 0$.*

(ii) *Let $Y \xrightarrow{f} X$ be an affine morphism. If \mathcal{N} is an \mathcal{O}_Y -module, then $H^q(X, f_*\mathcal{N})$ and $H^q(Y, \mathcal{N})$ are isomorphic. If Y is an affine variety, $H^q(X, f_*\mathcal{N}) = 0$ for all $q > 0$.* \square

One case in which (ii) applies is that f is the inclusion of a closed subvariety Y into X .

Let \mathcal{M} be a finite \mathcal{O} -module on projective space \mathbb{P}^n . The twisting modules $\mathcal{O}(d)$ and the twists $\mathcal{M}(d) = \mathcal{M} \otimes_{\mathcal{O}} \mathcal{O}(d)$ are isomorphic to $\mathcal{O}(dH)$ and $\mathcal{M}(dH)$, respectively (6.7.11). They form maps of directed sets

$$\begin{array}{ccccccc} \mathcal{O} & \xrightarrow{\subset} & \mathcal{O}(H) & \xrightarrow{\subset} & \mathcal{O}(2H) & \xrightarrow{\subset} & \dots & \mathcal{M} & \longrightarrow & \mathcal{M}(H) & \longrightarrow & \mathcal{M}(2H) & \longrightarrow & \dots \\ 1 \downarrow & & x_0 \downarrow & & x_0^2 \downarrow & & & 1 \downarrow & & x_0 \downarrow & & x_0^2 \downarrow & & \\ \mathcal{O} & \xrightarrow{x_0} & \mathcal{O}(1) & \xrightarrow{x_0} & \mathcal{O}(2) & \xrightarrow{x_0} & \dots & \mathcal{M} & \xrightarrow{x_0} & \mathcal{M}(1) & \xrightarrow{x_0} & \mathcal{M}(2) & \xrightarrow{x_0} & \dots \end{array}$$

(See (7.4.11)). The second diagram is obtained from the first one by tensoring with \mathcal{M} . Let \mathbb{U} denote the standard affine open subset \mathbb{U}^0 of \mathbb{P}^n , and let j be the inclusion of \mathbb{U} into \mathbb{P}^n . Then $\varinjlim \mathcal{O}(dH) \approx j_* \mathcal{O}_{\mathbb{U}}$ (6.7.16) and because \varinjlim is compatible with tensor products, $\varinjlim \mathcal{M}(dH) \approx j_* \mathcal{M}_{\mathbb{U}}$ (6.7.16). Since j is an affine morphism and \mathbb{U}^0 is an affine open set, $H^q(\mathbb{P}^n, j_* \mathcal{O}_{\mathbb{U}}) = 0$ and $H^q(\mathbb{P}^n, j_* \mathcal{M}_{\mathbb{U}}) = 0$ for all $q > 0$.

The next corollary follows from the facts that $\mathcal{M}(d)$ is isomorphic to $\mathcal{M}(dH)$, and that cohomology is compatible with direct limits (7.4.26).

7.5.2. Corollary. For all projective varieties X , all \mathcal{O} -modules \mathcal{M} , and all $q > 0$, $\varinjlim H^q(X, \mathcal{O}(d)) = 0$ and $\varinjlim H^q(X, \mathcal{M}(d)) = 0$. □

Onse-
quencetwo

7.5.3. Notation. If \mathcal{M} is an \mathcal{O} -module, we denote the dimension of $H^q(X, \mathcal{M})$ by $\mathbf{h}^q(X, \mathcal{M})$ or by $\mathbf{h}^q \mathcal{M}$. We can write $\mathbf{h}^q \mathcal{M} = \infty$ if the dimension is infinite. However, in Section 7.7, we will see that when \mathcal{M} is a finite \mathcal{O} -module on a projective variety X , $H^q(X, \mathcal{M})$ has finite dimension for every q .

dimnota-
tion

7.5.4. Theorem.

cohOd

(i) For $d \geq 0$, $\mathbf{h}^0(\mathbb{P}^n, \mathcal{O}(d)) = \binom{d+n}{n}$ and $\mathbf{h}^q(\mathbb{P}^n, \mathcal{O}(d)) = 0$ if $q \neq 0$.

(ii) For $r > 0$, $\mathbf{h}^n(\mathbb{P}^n, \mathcal{O}(-r)) = \binom{r-1}{n}$ and $\mathbf{h}^q(\mathbb{P}^n, \mathcal{O}(-r)) = 0$ if $q \neq n$.

Notethat, in particular, the case $r = 1$ in part (ii) asserts that $\mathbf{h}^q(\mathbb{P}^n, \mathcal{O}(-1)) = 0$ for all q .

proof. We have described the global sections of $\mathcal{O}(d)$ before: If $d \geq 0$, $H^0(X, \mathcal{O}(d))$ is the space of homogeneous polynomials of degree d in the coordinate variables, which is $\binom{d+n}{n}$, and $H^0(X, \mathcal{O}(d)) = 0$ if $d < 0$. (See (6.7.2).)

(i) (the case $d \geq 0$)

Let $X = \mathbb{P}^n$, and let $Y \xrightarrow{i} X$ be the inclusion of the hyperplane at infinity $x_0 = 0$ into X . By induction on n , we may assume that the theorem has been proved for Y , which is a projective space of dimension $n-1$. We consider the exact sequence

$$(7.5.5) \quad 0 \rightarrow \mathcal{O}_X(-1) \xrightarrow{x_0} \mathcal{O}_X \rightarrow i_* \mathcal{O}_Y \rightarrow 0$$

basecase

and its twists

$$(7.5.6) \quad 0 \rightarrow \mathcal{O}_X(d-1) \xrightarrow{x_0} \mathcal{O}_X(d) \rightarrow i_* \mathcal{O}_Y(d) \rightarrow 0$$

Od

The twisted sequences are exact because they are obtained by tensoring (7.5.5) with the invertible \mathcal{O} -modules $\mathcal{O}(d)$. Because the inclusion i is an affine morphism, $H^q(X, i_* \mathcal{O}_Y(d)) \approx H^q(Y, \mathcal{O}_Y(d))$ (7.5.1).

The monomials of degree d in $n+1$ variables form a basis of the space of global sections of $\mathcal{O}_X(d)$. Setting $x_0 = 0$ and deleting terms that become zero gives us a basis of $\mathcal{O}_Y(d)$. Every global section of $\mathcal{O}_Y(d)$ is the restriction of a global section of $\mathcal{O}_X(d)$. The sequence of global sections

$$0 \rightarrow H^0(X, \mathcal{O}_X(d-1)) \xrightarrow{x_0} H^0(X, \mathcal{O}_X(d)) \rightarrow H^0(Y, \mathcal{O}_Y(d)) \rightarrow 0$$

is exact. The cohomology sequence associated to (7.5.6) tells us that the map $H^1(X, \mathcal{O}_X(d-1)) \rightarrow H^1(X, \mathcal{O}_X(d))$ is injective.

By induction on the dimension n , $H^q(Y, \mathcal{O}_Y(d)) = 0$ for $d \geq 0$ and $q > 0$. When combined with the injectivity noted above, the cohomology sequence of (7.5.6) shows that the maps $H^q(X, \mathcal{O}_X(d-1)) \rightarrow$

$H^q(X, \mathcal{O}_X(d))$ are bijective for every $q > 0$. Since the limits are zero (7.5.2), $H^q(X, \mathcal{O}_X(d)) = 0$ for all $d \geq 0$ and all $q > 0$.

(ii) (the case $d < 0$, or $r > 0$.)

We use induction on the integers r and n . We suppose the theorem proved for r , and we substitute $d = -r$ into the sequence (7.5.6):

Or (7.5.7)
$$0 \rightarrow \mathcal{O}_X(-(r+1)) \xrightarrow{x_0} \mathcal{O}_X(-r) \rightarrow i_*\mathcal{O}_Y(-r) \rightarrow 0$$

The base case $r = 0$ is the exact sequence (7.5.5). In the cohomology sequence associated to that sequence, the terms $H^q(X, \mathcal{O}_X)$ and $H^q(Y, \mathcal{O}_Y)$ are zero when $q > 0$, and $H^0(X, \mathcal{O}_X) = H^0(Y, \mathcal{O}_Y) = \mathbb{C}$. Therefore $H^q(X, \mathcal{O}_X(-1)) = 0$ for every q . This proves (ii) for $r = 1$.

Our induction hypothesis is that, $\mathbf{h}^n(X, \mathcal{O}(-r)) = \binom{r-1}{n}$ and $\mathbf{h}^q = 0$ if $q \neq n$. By induction on n , we may suppose that $\mathbf{h}^{n-1}(Y, \mathcal{O}(-r)) = \binom{r-1}{n-1}$ and that $\mathbf{h}^q = 0$ if $q \neq n-1$. Instead of displaying the cohomology sequence associated to (7.5.7), we assemble the dimensions of cohomology into a table in which the asterisks stand for entries that are to be determined:

co-
hdimstwo

(7.5.8)
$$\begin{array}{cccc} & \mathcal{O}_X(-(r+1)) & \mathcal{O}_X(-r) & i_*\mathcal{O}_Y(-r) \\ \mathbf{h}^0 & : & * & 0 & 0 \\ & & \vdots & \vdots & \vdots \\ \mathbf{h}^{n-2} & : & * & 0 & 0 \\ \mathbf{h}^{n-1} & : & * & 0 & \binom{r-1}{n-1} \\ \mathbf{h}^n & : & * & \binom{r-1}{n} & 0 \end{array}$$

The second column is determined, as above, by induction on r and the third column is determined by induction on n . The cohomology sequence shows that that

$$\mathbf{h}^n(X, \mathcal{O}(-(r+1))) = \binom{r-1}{n-1} + \binom{r-1}{n}$$

and that the other entries labeled with an asterisk are zero. The right side of this equation is equal to $\binom{r}{n}$. \square

7.6 Cohomology of Hypersurfaces

cohyper

We determine the cohomology of a plane projective curve first. Let X be the projective plane \mathbb{P}^2 and let $C \xrightarrow{i} X$ denote the inclusion of a plane curve C of degree k . The ideal \mathcal{I} of functions that vanish on C is isomorphic to the twisting module $\mathcal{O}_X(-k)$ (6.7.8). So one has an exact sequence

coh-
planecurvetwo

(7.6.1)
$$0 \rightarrow \mathcal{O}_X(-k) \rightarrow \mathcal{O}_X \rightarrow i_*\mathcal{O}_C \rightarrow 0$$

We form a table showing dimensions of the cohomology on X . Theorem 7.5.4 determines the first two columns, and the cohomology sequence determines the last column.

cohdims

(7.6.2)
$$\begin{array}{ccc} & \mathcal{O}_X(-k) & \mathcal{O}_X & i_*\mathcal{O}_C \\ \mathbf{h}^0 & : & 0 & 1 & 1 \\ \mathbf{h}^1 & : & 0 & 0 & \binom{k-1}{2} \\ \mathbf{h}^2 & : & \binom{k-1}{2} & 0 & 0 \end{array}$$

Since the inclusion of the curve C into the projective plane X is an affine morphism, $\mathbf{h}^q(C, \mathcal{O}_C) = \mathbf{h}^q(X, i_*\mathcal{O}_C)$. Therefore

$$\mathbf{h}^0(C, \mathcal{O}_C) = 1, \mathbf{h}^1(C, \mathcal{O}_C) = \binom{k-1}{2}, \text{ and } \mathbf{h}^q = 0 \text{ when } q > 1.$$

The dimension $\mathbf{h}^1(C, \mathcal{O}_C)$, which is $\binom{k-1}{2}$, is called the *arithmetic genus* of C . It is denoted by $p_a (= p_a(C))$. We will see later (8.8.2) that when C is a smooth curve, its arithmetic genus is equal to its topological genus: $p_a = g$. But the arithmetic genus of a plane curve of degree k is $\binom{k-1}{2}$ also when the curve C is singular.

We restate the results as a corollary.

7.6.3. Corollary. *Let C be a plane curve of degree k . Then $\mathbf{h}^0\mathcal{O}_C = 1$, $\mathbf{h}^1\mathcal{O}_C = \binom{k-1}{2} = p_a$, and $\mathbf{h}^q = 0$ if $q \neq 0, 1$. \square*

*coh-
plane curve*

The fact that $\mathbf{h}^0\mathcal{O}_C = 1$ tells us that the only rational functions that are regular everywhere on C are the constants. This reflects a fact that will be proved later: A plane curve is compact and connected in the classical topology. However, it isn't a proof of that fact.

In the next section we will see that the cohomology on any projective curve is zero except in dimensions 0 and 1. However, we will need more technique in order to compute cohomology when a curve is embedded in a higher dimensional projective space. Cohomology of projective curves is the topic of Chapter 8.

One can make a similar computation for the hypersurface Y in $X = \mathbb{P}^n$ defined by an irreducible homogeneous polynomial f of degree k . The ideal of Y is isomorphic to $\mathcal{O}_X(-k)$ (6.7.8), and there is an exact sequence

$$0 \rightarrow \mathcal{O}_X(-k) \xrightarrow{f} \mathcal{O}_X \rightarrow i_*\mathcal{O}_Y \rightarrow 0$$

Since we know the cohomology of $\mathcal{O}_X(-k)$ and of \mathcal{O}_X , and since $H^q(X, i_*\mathcal{O}_Y) \approx H^q(Y, \mathcal{O}_Y)$, we can use this sequence to compute the dimensions of the cohomology of \mathcal{O}_Y .

7.6.4. Corollary. *Let Y be a hypersurface of dimension d and degree k in a projective space of dimension $d + 1$. Then $\mathbf{h}^0(Y, \mathcal{O}_Y) = 1$, $\mathbf{h}^d(Y, \mathcal{O}_Y) = \binom{k-1}{d+1}$, and $\mathbf{h}^q(Y, \mathcal{O}_Y) = 0$ for all other q . \square*

*cohyper-
surface*

In particular, when S is the surface in \mathbb{P}^3 defined by an irreducible polynomial of degree k , $\mathbf{h}^0(S, \mathcal{O}_S) = 1$, $\mathbf{h}^1(S, \mathcal{O}_S) = 0$, $\mathbf{h}^2(S, \mathcal{O}_S) = \binom{k-1}{3}$, and $\mathbf{h}^q = 0$ if $q > 2$. For a projective surface S that isn't embedded into \mathbb{P}^3 , it is still true that $\mathbf{h}^q = 0$ when $q > 2$, but $\mathbf{h}^1(S, \mathcal{O}_S)$ may be nonzero. The dimensions $\mathbf{h}^1(S, \mathcal{O}_S)$ and $\mathbf{h}^2(S, \mathcal{O}_S)$ are invariants of the surface S that are somewhat analogous to the genus of a curve. In classical terminology, $\mathbf{h}^2(S, \mathcal{O}_S)$ is the *geometric genus* p_g and $\mathbf{h}^1(S, \mathcal{O}_S)$ is the *irregularity* q . The *arithmetic genus* p_a of S is defined to be

$$(7.6.5) \quad p_a = \mathbf{h}^2(S, \mathcal{O}_S) - \mathbf{h}^1(S, \mathcal{O}_S) = p_g - q$$

patwo

Therefore the irregularity is $q = p_g - p_a$. When S is a surface in \mathbb{P}^3 , $q = 0$ and $p_g = p_a$.

In modern terminology, it would be more natural to replace the arithmetic genus by the Euler characteristic of the structure sheaf $\chi(\mathcal{O}_S)$, which is defined to be $\sum_q (-1)^q \mathbf{h}^q \mathcal{O}_S$ (see 7.7.7) below. The Euler characteristic of the structure sheaf on a curve is

$$\chi(\mathcal{O}_C) = \mathbf{h}^0(C, \mathcal{O}_C) - \mathbf{h}^1(C, \mathcal{O}_C) = 1 - p_a$$

and on a surface S it is

$$\chi(\mathcal{O}_S) = \mathbf{h}^0(S, \mathcal{O}_S) - \mathbf{h}^1(S, \mathcal{O}_S) + \mathbf{h}^2(S, \mathcal{O}_S) = 1 + p_a$$

But because of tradition, the arithmetic genus is still used quite often.

7.7 Three Theorems about Cohomology

These theorems are taken from Serre's 1956 paper.

threethms

7.7.1. Theorem. *Let X be a projective variety, and let \mathcal{M} be a finite \mathcal{O}_X -module. If the support of \mathcal{M} has dimension k , then $H^q(X, \mathcal{M}) = 0$ for all $q > k$. In particular, if X has dimension n , then $H^q(X, \mathcal{M}) = 0$ for all $q > n$.*

*cohsup-
port*

See Section 6.6 for the definition of support.

7.7.2. Theorem. *Let $\mathcal{M}(d)$ be the twist of a finite \mathcal{O}_X -module \mathcal{M} on a projective variety X . For sufficiently large d , $H^q(X, \mathcal{M}(d)) = 0$ for all $q > 0$.*

largetwist

7.7.3. Theorem. *Let \mathcal{M} be a finite \mathcal{O} -module on a projective variety X . The cohomology $H^q(X, \mathcal{M})$ is a finite-dimensional vector space for every q .*

findim

descind

7.7.4. Notes. (a) As the first theorem asserts, the highest dimension in which cohomology of an \mathcal{O}_X -module on a projective variety X can be nonzero is the dimension of X . It is also true that, when X has dimension n , there will be \mathcal{O}_X -modules \mathcal{M} such that $H^n(X, \mathcal{M}) \neq 0$. In contrast, in the classical topology on a projective variety X of dimension n , the constant coefficient cohomology $H^{2n}(X_{class}, \mathbb{Z})$ isn't zero. As we have mentioned, in the Zariski topology, the constant coefficient cohomology $H^q(X, \mathbb{Z})$ is zero for every $q > 0$. And when X is affine, the cohomology of an \mathcal{O}_X -module is zero for every $q > 0$.

(b) The third theorem tells us that the space of global sections $h^0 \mathcal{M}$ of a finite \mathcal{O} -module \mathcal{M} on a projective variety is finite-dimensional. This is one of the most important consequences of the theorem, and it isn't easy to prove directly. When a variety isn't projective, cohomology needn't be finite-dimensional. For example, on an affine variety $X = \text{Spec } A$, $H^0(X, \mathcal{O}) = A$ isn't finite-dimensional unless X is a point. When X is the complement of a point in \mathbb{P}^2 , $H^1(X, \mathcal{O})$ isn't finite-dimensional.

(c) The structure of the proofs is interesting. The first theorem allows us to use *descending* induction to prove the second and third theorems, beginning with the fact that $H^k(X, \mathcal{M}) = 0$ when k is greater than the dimension of X . \square

In the three theorems, we are given that X is a closed subvariety of a projective space \mathbb{P}^n . We can replace an \mathcal{O}_X -module by its extension by zero to \mathbb{P}^n (7.5.1). This doesn't change the cohomology or the dimension of support. In fact, the twist $\mathcal{M}(d)$ of an \mathcal{O}_X -module that is referred to in the second theorem is defined in terms of the extension by zero. So we may assume that X is a projective space.

The proofs are based on the cohomology of the twisting modules (7.5.4) and the vanishing of the limit $\varinjlim H^q(X, \mathcal{M}(d))$ for $q > 0$ (7.5.2).

proof of Theorem 7.7.1 (vanishing in large dimension)

Here \mathcal{M} is a finite \mathcal{O} -module whose support S has dimension at most k . We are to show that $H^q(X, \mathcal{M}) = 0$ when $q > k$. We choose coordinates so that the hyperplane $H : x_0 = 0$ doesn't contain any component of the support S . Then $H \cap S$ has dimension at most $k - 1$. We inspect the multiplication map $\mathcal{M}(-1) \xrightarrow{x_0} \mathcal{M}$. The kernel \mathcal{K} and cokernel \mathcal{Q} are annihilated by x_0 , so the supports of \mathcal{K} and \mathcal{Q} are contained in H . Since they are also in S , the supports have dimension at most $k - 1$. We can apply induction on k to them. In the base case $k = 0$, the supports of \mathcal{K} and \mathcal{Q} will be empty, and their cohomology will be zero.

We break the exact sequence $0 \rightarrow \mathcal{K} \rightarrow \mathcal{M}(-1) \rightarrow \mathcal{M} \rightarrow \mathcal{Q} \rightarrow 0$ into two short exact sequences by introducing the \mathcal{O} -module $\mathcal{N} = \ker(\mathcal{M} \rightarrow \mathcal{Q})$:

kercoker

$$(7.7.5) \quad 0 \rightarrow \mathcal{K} \rightarrow \mathcal{M}(-1) \rightarrow \mathcal{N} \rightarrow 0 \quad \text{and} \quad 0 \rightarrow \mathcal{N} \rightarrow \mathcal{M} \rightarrow \mathcal{Q} \rightarrow 0$$

The induction hypothesis applies to \mathcal{K} and to \mathcal{Q} . When $q \geq k$, $H^q(X, \mathcal{K}) = H^q(X, \mathcal{Q}) = 0$. For $q > k$, the relevant parts of the cohomology sequences associated to the exact sequences become

$$0 \rightarrow H^q(X, \mathcal{M}(-1)) \rightarrow H^q(X, \mathcal{N}) \rightarrow 0 \quad \text{and} \quad 0 \rightarrow H^q(X, \mathcal{N}) \rightarrow H^q(X, \mathcal{M}) \rightarrow 0$$

respectively. Therefore the maps $H^q(X, \mathcal{M}(-1)) \rightarrow H^q(X, \mathcal{N}) \rightarrow H^q(X, \mathcal{M})$ are bijective, and this is true for every \mathcal{O} -module whose support has dimension at most k , including for the \mathcal{O} -module $\mathcal{M}(d)$. For every d and every $q > k$, the map $H^q(X, \mathcal{M}(d-1)) \rightarrow H^q(X, \mathcal{M}(d))$ is bijective.

According to (7.5.2), $\varinjlim H^q(X, \mathcal{M}(d)) = 0$. It follows that, when $q > k$, $H^q(X, \mathcal{M}(d)) = 0$ for all d , and in particular, $H^q(X, \mathcal{M}) = 0$.

proof of Theorem 7.7.2 (vanishing for a large twist)

Let \mathcal{M} be a finite \mathcal{O} -module on a projective variety X . We recall that $\mathcal{M}(r)$ is generated by global sections when r is sufficiently large (6.7.21). Choosing generators gives us a surjective map $\mathcal{O}^r \rightarrow \mathcal{M}(r)$. Let \mathcal{N} be the kernel of this map. When we twist the sequence $0 \rightarrow \mathcal{N} \rightarrow \mathcal{O}^r \rightarrow \mathcal{M}(r) \rightarrow 0$, we obtain short exact sequences

threetwos

$$(7.7.6) \quad 0 \rightarrow \mathcal{N}(d) \rightarrow \mathcal{O}(d)^r \rightarrow \mathcal{M}(d+r) \rightarrow 0$$

for every $d \geq 0$. These sequences are useful because $H^q(X, \mathcal{O}(d)) = 0$ when $q > 0$ (7.5.4).

We go to the proof of Theorem 7.7.2 now. We must show this:

(*) Let \mathcal{M} be a finite \mathcal{O} -module. For sufficiently large d and for all $q > 0$, $H^q(X, \mathcal{M}(d)) = 0$.

Let n be the dimension of X . By Theorem 7.7.1, $H^q(X, \mathcal{M}) = 0$ for any \mathcal{O} -module \mathcal{M} , when $q > n$, in particular, for the twists $\mathcal{M}(d)$ of \mathcal{M} . This leaves a finite set of integers $q = 1, \dots, n$ to consider, and it suffices to consider them one at a time. If (*) is true for each individual q it will be true for the finite set of integers $q = 1, \dots, n$ at the same time, and therefore for all positive integers q , as the theorem asserts.

We use descending induction on q , the base case being $q = n + 1$, for which (*) is true. We suppose that (*) is true for every finite \mathcal{O} -module \mathcal{M} when $q = p + 1$, and that $p > 0$, and we show that (*) is true for every finite \mathcal{O} -module \mathcal{M} when $q = p$.

We substitute $q = p$ into the cohomology sequence associated to the sequence (7.7.6). The relevant part of that sequence is

$$H^p(X, \mathcal{O}(d)^m) \rightarrow H^p(X, \mathcal{M}(d+r)) \xrightarrow{\delta^p} H^{p+1}(X, \mathcal{N}(d))$$

Since p is positive, $H^p(X, \mathcal{O}(d)) = 0$ for all $d \geq 0$, and therefore the map δ^p is injective. Our induction hypothesis, applied to the \mathcal{O} -module \mathcal{N} , shows that $H^{p+1}(X, \mathcal{N}(d)) = 0$ if d is large, and then

$$H^p(X, \mathcal{M}(d+r)) = 0$$

The particular integer $d+r$ isn't useful. Our conclusion is that, for every finite \mathcal{O} -module \mathcal{M} , $H^p(X, \mathcal{M}(k)) = 0$ when k is large enough. \square

proof of Theorem 7.7.3 (finiteness of cohomology)

This proof uses ascending induction on the dimension of support as well as descending induction on the degree d of a twist. As was mentioned above, it isn't easy to prove directly that the space $H^0(X, \mathcal{M})$ of global sections is finite-dimensional.

We go back to the sequences (7.7.5) and their cohomology sequences. Ascending induction on the dimension of the support of \mathcal{M} allows us to assume that $H^r(X, \mathcal{K})$ and $H^r(X, \mathcal{Q})$ are finite-dimensional for all r . Denoting finite-dimensional spaces ambiguously by *Fin*, the two cohomology sequences become

$$\dots \rightarrow \text{Fin} \rightarrow H^q(X, \mathcal{M}(-1)) \rightarrow H^q(X, \mathcal{N}) \rightarrow \text{Fin} \rightarrow \dots$$

and

$$\dots \rightarrow \text{Fin} \rightarrow H^q(X, \mathcal{N}) \rightarrow H^q(X, \mathcal{M}) \rightarrow \text{Fin} \rightarrow \dots$$

The first sequence shows that if $H^q(X, \mathcal{M}(-1))$ has infinite dimension, then $H^q(X, \mathcal{N})$ also has infinite dimension, and the second sequence shows that if $H^q(X, \mathcal{N})$ has infinite dimension, then $H^q(X, \mathcal{M})$ has infinite dimension too. Therefore $H^q(X, \mathcal{M}(-1))$ and $H^q(X, \mathcal{M})$ are either both finite-dimensional, or else they are both infinite-dimensional. This applies to the twisted modules $\mathcal{M}(d)$ as well as to \mathcal{M} . $H^q(X, \mathcal{M}(d-1))$ and $H^q(X, \mathcal{M}(d))$ are both finite-dimensional or both infinite-dimensional.

Suppose that $q > 0$. Then $H^q(X, \mathcal{M}(d)) = 0$ when d is large enough (Theorem 7.7.2). Since the zero space is finite-dimensional, we can use the sequence together with descending induction on d , to conclude that $H^q(X, \mathcal{M}(d))$ is finite-dimensional for every finite module \mathcal{M} and every d . In particular, $H^q(X, \mathcal{M})$ is finite-dimensional.

This leaves the case that $q = 0$. To prove that $H^0(X, \mathcal{M})$ is finite-dimensional, we set $d = -r$ in the sequence (7.7.6):

$$0 \rightarrow \mathcal{N}(-r) \rightarrow \mathcal{O}(-r)^m \rightarrow \mathcal{M} \rightarrow 0$$

The corresponding cohomology sequence is

$$0 \rightarrow H^0(X, \mathcal{N}(-r)) \rightarrow H^0(X, \mathcal{O}(-r))^m \rightarrow H^0(X, \mathcal{M}) \xrightarrow{\delta^0} H^1(X, \mathcal{N}(-r)) \rightarrow \dots$$

Here $H^0(X, \mathcal{O}(-r))^m = 0$, and we've shown that $H^1(X, \mathcal{N}(-r))$ is finite-dimensional. It follows that $H^0(X, \mathcal{M})$ is finite-dimensional, and this completes the proof. \square

Notice that the finiteness of H^0 comes out only at the end. The higher cohomology is essential for the proof.

eulerchar (7.7.7) **Euler characteristic**

Theorems 7.7.1 and (7.7.3) allow us to define the Euler characteristic of a finite module on projective variety.

defeuler **7.7.8. Definition.** Let X be a projective variety. The *Euler characteristic of a finite \mathcal{O} -module \mathcal{M}* is the alternating sum of the dimensions of the cohomology:

chi (7.7.9)
$$\chi(\mathcal{M}) = \sum (-1)^q \mathbf{h}^q(X, \mathcal{M}).$$

This makes sense because $\mathbf{h}^q(X, \mathcal{M})$ is finite for every q , and is zero when q is large.

Try not to confuse the Euler characteristic of an \mathcal{O} -module with the topological Euler characteristic of the variety X .

7.7.10. Proposition. (i) If $0 \rightarrow \mathcal{M} \rightarrow \mathcal{N} \rightarrow \mathcal{P} \rightarrow 0$ is a short exact sequence of finite \mathcal{O} -modules on a projective variety X , then $\chi(\mathcal{M}) - \chi(\mathcal{N}) + \chi(\mathcal{P}) = 0$.

(ii) If $0 \rightarrow \mathcal{M}_0 \rightarrow \mathcal{M}_1 \rightarrow \dots \rightarrow \mathcal{M}_n \rightarrow 0$ is an exact sequence of finite \mathcal{O} -modules on X , the alternating sum $\sum (-1)^i \chi(\mathcal{M}_i)$ is zero.

altsum **7.7.11. Lemma.** Let $0 \rightarrow V^0 \rightarrow V^1 \rightarrow \dots \rightarrow V^n \rightarrow 0$ be an exact sequence of finite dimensional vector spaces. The alternating sum $\sum (-1)^q \dim V^q$ is zero. □

proof of Proposition 7.7.10. (i) Let n be the dimension of X . The cohomology sequence associated to the given sequence is

$$0 \rightarrow H^0(\mathcal{M}) \rightarrow H^0(\mathcal{N}) \rightarrow H^0(\mathcal{P}) \rightarrow H^1(\mathcal{M}) \rightarrow H^1(\mathcal{N}) \rightarrow \dots \rightarrow H^n(\mathcal{P}) \rightarrow 0$$

and the lemma tells us that the alternating sum of its dimensions is zero. That alternating sum is also equal to $\chi(\mathcal{M}) - \chi(\mathcal{N}) + \chi(\mathcal{P})$.

(ii) Let \mathcal{S} 's denote the given sequence by \mathbb{S}_0 and the alternating sum $\sum_i (-1)^i \chi(\mathcal{M}_i)$ by $\chi(\mathbb{S}_0)$.

Let $\mathcal{N} = \mathcal{M}_1/\mathcal{M}_0$. The sequence \mathbb{S}_0 decomposes into the two exact sequences

$$\mathbb{S}_1 : 0 \rightarrow \mathcal{M}_0 \rightarrow \mathcal{M}_1 \rightarrow \mathcal{N} \rightarrow 0 \quad \text{and} \quad \mathbb{S}_2 : 0 \rightarrow \mathcal{N} \rightarrow \mathcal{M}_2 \rightarrow \dots \rightarrow \mathcal{M}_k \rightarrow 0$$

One sees directly that $\chi(\mathbb{S}_0) = \chi(\mathbb{S}_1) - \chi(\mathbb{S}_2)$, and then the assertion follows from **(i)** by induction on n . □

7.8 Bézout's Theorem

bezout

As an application of cohomology, we use it to prove Bézout's Theorem.

If $f(x) = p_1(x)^{e_1} \dots p_k(x)^{e_k}$ is a factorization of a homogeneous polynomial $f(x_0, x_1, x_2)$ into irreducible polynomials, the *divisor* of f is defined to be the integer combination $e_1 C_1 + \dots + e_k C_k$, where C_i is the curve of zeros of p_i .

We restate the theorem to be proved.

be- **7.8.1. Bézout's Theorem.** Let Y and Z be the divisors in the projective plane X defined by relatively prime homogeneous polynomials f and g of degrees m and n , respectively. The number of intersection points $Y \cap Z$, when counted with an appropriate multiplicity, is equal to mn . Moreover, the multiplicity is 1 at a point at which Y and Z intersect transversally.

The definition of the multiplicity will emerge during the proof.

intersect- **7.8.2. Example.** Suppose that f and g are products of linear polynomials, so that Y is the union of m lines and Z is the union of n lines, and suppose that those lines are distinct. Since distinct lines intersect transversally in a single point, there are mn intersection points of multiplicity 1. □

proof of Bézout's Theorem. Multiplication by f defines a short exact sequence

$$0 \rightarrow \mathcal{O}_X(-m) \xrightarrow{f} \mathcal{O}_X \rightarrow \mathcal{A} \rightarrow 0$$

where \mathcal{A} stands for the quotient $\mathcal{O}/f\mathcal{O}(-m)$. If f is a irreducible, \mathcal{A} will be the extension by zero of the structure sheaf on Y . When f is reducible, Y won't be a variety. That is why we denote the quotient by \mathcal{A} . This sequence describes $\mathcal{O}_X(-m)$ as the ideal \mathcal{I} of Y , and there is a similar sequence describing the module $\mathcal{O}_X(-n)$ as the ideal \mathcal{J} of Z . The zero locus of the ideal $\mathcal{I}+\mathcal{J}$ is the intersection $Y \cap Z$.

Let $\overline{\mathcal{O}}$ denote the quotient $\mathcal{O}_X/(\mathcal{I}+\mathcal{J})$. Since f and g have no common factor, $Y \cap Z$ is a finite set of points $\{p_1, \dots, p_k\}$, and $\overline{\mathcal{O}}$ is isomorphic to a direct sum $\bigoplus \overline{\mathcal{O}}_i$, where $\overline{\mathcal{O}}_i$ is a finite-dimensional algebra whose support is p_i (6.6.4). We define the *intersection multiplicity* of Y and Z at p_i to be the dimension of $\overline{\mathcal{O}}_i$, which is also equal to the dimension $\mathbf{h}^0(X, \overline{\mathcal{O}}_i)$ of its space of its global sections. Let's denote that multiplicity by μ_i . The dimension of $H^0(X, \overline{\mathcal{O}})$ is the sum $\mu_1 + \dots + \mu_k$, and $H^q(X, \overline{\mathcal{O}}) = 0$ for all $q > 0$ (Theorem 7.7.1). So the Euler characteristic $\chi(\overline{\mathcal{O}})$ is equal to $\mathbf{h}^0(X, \overline{\mathcal{O}})$. We'll show that $\chi(\overline{\mathcal{O}}) = mn$, and therefore that $\mu_1 + \dots + \mu_k = mn$. This will prove Bézout's Theorem.

We form an exact sequence of \mathcal{O} -modules, in which $\mathcal{O} = \mathcal{O}_X$:

$$(7.8.3) \quad 0 \rightarrow \mathcal{O}(-m-n) \xrightarrow{(g,f)^t} \mathcal{O}(-m) \times \mathcal{O}(-n) \xrightarrow{(f,-g)} \mathcal{O} \xrightarrow{\pi} \overline{\mathcal{O}} \rightarrow 0$$

bezoutres-
olution

In order to interpret the maps in this sequence as matrix multiplication with homomorphisms acting on the left, sections of $\mathcal{O}(-m) \times \mathcal{O}(-n)$ should be represented as column vectors $(u, v)^t$, u and v being sections of $\mathcal{O}(-m)$ and $\mathcal{O}(-n)$, respectively.

7.8.4. Lemma. *The sequence (7.8.3) is exact.*

bresolex-
act

proof. To prove exactness, it suffices to show that the sequence of sections on each of the standard affine open sets is exact. Let's suppose that coordinates have been chosen so that none of the points making up $Y \cap Z$ lie on the coordinate axes. We look at \mathbb{U}^0 , as usual. Let A be the algebra of regular functions on \mathbb{U}^0 , the polynomial algebra $\mathbb{C}[u_1, u_2]$, with $u_i = x_i/x_0$. We identify $\mathcal{O}(k)$ with $\mathcal{O}(kH)$, H being the hyperplane at infinity. The restriction of the module $\mathcal{O}(kH)$ to \mathbb{U}^0 is isomorphic to $\mathcal{O}_{\mathbb{U}^0}$. Its sections on \mathbb{U}^0 are the elements of A . Let \overline{A} be the algebra of sections of $\overline{\mathcal{O}}$ on \mathbb{U}^0 . Since f and g are relatively prime, so are their dehomogenizations $F = f(1, u_1, u_2)$ and $G = g(1, u_1, u_2)$. The sequence of sections of (7.8.3) on \mathbb{U}^0 is

$$0 \rightarrow A \xrightarrow{(G,F)^t} A \times A \xrightarrow{(F,-G)} A \rightarrow \overline{A} \rightarrow 0$$

and the only place at which exactness of this sequence isn't obvious is at $A \times A$. Suppose that $(u, v)^t$ is in the kernel of the map $(F, -G)$, i.e., that $Fu = Gv$. Since F and G are relatively prime, F divides v , G divides u , and $v/F = u/G$. Let $w = v/F = u/G$. Then $(u, v)^t = (G, F)^t w$. \square

We go back to the proof of Bézout's Theorem. Proposition 7.7.10(ii), applied to the exact sequence (7.8.3), tells us that the alternating sum

$$(7.8.5) \quad \chi(\mathcal{O}(-m-n)) - \chi(\mathcal{O}(-m)) + (\chi(\mathcal{O}(-n) \times \mathcal{O}(-n)) - \chi(\overline{\mathcal{O}}))$$

chiforbe-
zout

is zero. Since cohomology is compatible with products, $\chi(\mathcal{M} \times \mathcal{N}) = \chi(\mathcal{M}) + \chi(\mathcal{N})$ for any \mathcal{O} -modules \mathcal{M} and \mathcal{N} . Solving for $\chi(\overline{\mathcal{O}})$ and applying Theorem 7.5.4,

$$\chi(\overline{\mathcal{O}}) = \binom{n+m-1}{2} - \binom{m-1}{2} - \binom{n-1}{2} + 1$$

This equation shows that the term $\chi(\overline{\mathcal{O}})$ depends only on the integers m and n . Since we know that the answer is mn when Y and Z are unions of distinct lines, it is mn in every case. This completes the proof.

If you are suspicious of this reasoning, you can evaluate the right side of the equation. \square

We still need to explain the assertion that the mutiplicity at a transversal intersection p is equal to 1. This will be true if and only if $\mathcal{I}+\mathcal{J}$ generates the maximal ideal \mathfrak{m} of $A = \mathbb{C}[y, z]$ at p locally, and it is obvious when Y and Z are lines. In that case we may choose affine coordinates so that p is the origin in $\mathbb{A}^2 = \text{Spec } A$ and the curves are the coordinate axes $\{z = 0\}$ and $\{y = 0\}$. The variables y, z generate the maximal ideal at the origin, so the quotient algebra $k = A/\mathfrak{m}$ has dimension 1.

Suppose that Y and Z intersect transversally at p , but that they aren't lines. We choose affine coordinates so that p is the origin and that the tangent directions of Y and Z at p are the coordinate axes. The affine equations of Y and Z will have the form $y' = 0$ and $z' = 0$, where $y' = y + g(y, z)$ and $z' = z + h(y, z)$, g and h being polynomials all of whose terms have degree at least 2. Because Y and Z may intersect at points other than p , the elements y' and z' may not generate the maximal ideal \mathfrak{m} at p . However, it suffices to show that they generate the maximal ideal locally. The proof here is clumsy.

The locus $Y \cap Z$ in the plane X is the intersection of two distinct curves in X , so it is a finite set. We choose an element s of A that is not zero at p , but is zero at the other points of $Y \cap Z$. Then in X_s the locus $y' = z' = 0$ is p .

In A_s , let I be the ideal generated by x', y' . We map a free A_s -module V with basis x', y' to I . Let C be the cokernel of that map. Tensoring the exact sequence $V \rightarrow I \rightarrow C \rightarrow 0$ with the residue field $k = A/\mathfrak{m}$ gives us an exact sequence $\bar{V} \rightarrow \bar{I} \rightarrow \bar{C} \rightarrow 0$. The map $\bar{V} \rightarrow \bar{I}$ is surjective, so $\bar{C} = 0$. The Local Nakayama Lemma tells us that the localization of C at p is zero. Then, since C is supported at p , $C = 0$. \square

7.9 Exercises

7.9.1. Let $V = 0 \rightarrow V_0 \rightarrow \cdots \rightarrow V_n \rightarrow 0$ be a complex of finite-dimensional vector spaces. Prove that $\sum_i (-1)^i \dim V_i = \sum_i (-1)^i = \sum (-1)^q \mathbf{C}^q(V^\bullet)$.

chapsev-
exerc

7.9.2. Let $0 \rightarrow \mathcal{M}_0 \rightarrow \cdots \rightarrow \mathcal{M}_k \rightarrow 0$ be an exact sequence of \mathcal{O} -modules on a variety X . Prove that if $H^q(\mathcal{M}_i) = 0$ for all $q > 0$ and all i , the sequence of global sections is exact.

7.9.3. Prove that cohomology compatible with products

xcohprod

(a) of two modules

(b) of an arbitrary family of modules.

7.9.4. Let A, B be 2×2 variable matrices, let P be the polynomial ring $\mathbb{C}[a_{ij}, b_{ij}]$, and let R be the algebra $P/(AB - BA)$. Show that R has a resolution as P -module of the form $0 \rightarrow P^2 \rightarrow P^3 \rightarrow P \rightarrow R \rightarrow 0$. (Hint: Write the equations in terms of $a_{11} - a_{22}$ and $b_{11} - b_{22}$.)

xABBA

7.9.5. Prove that a variety of any dimension contains no isolated point.

xnoisolpt

7.9.6. Prove that a regular function on a projective variety is constant.

xregfn-
const

7.9.7. Let C be a plane curve of degree d with δ nodes and κ cusps, and let C' be its normalization. Determine the genus of C' .

7.9.8. Prove that if X is a projective variety, then $H^0(\mathcal{O}_X) = \mathbb{C}$.

7.9.9. the Cousin problem: Let $\{U^i\}$ be an open covering of projective space. Suppose that rational functions f_i are given such that $f_i - f_j$ is a regular function on $U^i \cap U^j$. The problem is to find a rational function f such that $f - f_i$ is a regular function on U^i for every i . Analyze this problem making use of the exact sequence $0 \rightarrow \mathcal{O} \rightarrow \mathcal{F} \rightarrow \mathcal{Q} \rightarrow 0$, where \mathcal{F} is the constant function field module and \mathcal{Q} is the quotient \mathcal{F}/\mathcal{O} .

xcousin

7.9.10. A hexagon in \mathbb{P}^2 is any collection ℓ_0, \dots, ℓ_5 of six distinct lines. Let $p_i = \ell_i \cap \ell_{i+1}$ for $i = 1, \dots, 5$ and $p_0 = \ell_5 \cap \ell_0$. Assuming that these intersections are distinct, they the *vertices* of the hexagon. Pascal's Theorem asserts that if the vertices of a hexagon lie on a conic C , then the three points $q_1 = \ell_1 \cap \ell_4$, $q_2 = \ell_2 \cap \ell_5$ and $q_3 = \ell_3 \cap \ell_0$ lie on a line. Let L be the line through q_1 and q_2 . Let f_1, f_2, g be homogeneous cubics whose zero loci are $\ell_1 + \ell_3 + \ell_5$, $\ell_0 + \ell_2 + \ell_4$, and $C + L$, respectively, and let $h = f_1 + g$. Prove Pascal's Theorem by applying Bézout's theorem to the divisors of zeros of f_1, f_2, g and h .

xpascal

7.9.11. Prove that if a variety is covered by two affine open sets, its cohomology is zero in dimensions greater than one.

xcohdi-
mone

7.9.12. Prove that $\mathfrak{m}_1^{e_1} \cdots \mathfrak{m}_k^{e_k}$ is isomorphic to the tensor product $\mathfrak{m}_1^{\otimes e_1} \otimes_{\mathcal{O}} \cdots \otimes_{\mathcal{O}} \mathfrak{m}_k^{\otimes e_k}$.

xideal-
tensor

rethink this

7.9.13. Let p_1, p_2, p_3 and q_1, q_2, q_3 be six points that lie on a conic C , and for $i \neq j$, let L_{ij} be the lines through the points p_i and q_j , and let $r_1 = L_{23} \cap L_{32}$, $r_2 = L_{31} \cap L_{13}$, and $r_3 = L_{12} \cap L_{21}$.

expascal

(i) Pascal's Theorem asserts that the three points r_1, r_2 and r_3 lie on a line. Prove Pascal's Theorem following this outline: Let g and h be the homogeneous cubic polynomials whose zero loci are $L_{12} \cup L_{13} \cup L_{23}$ and $L_{21} \cup L_{31} \cup L_{32}$, respectively, and let x be a point of the conic C .

(ii) Show that there is a unique scalar c such that the cubic $f = g + ch$ vanishes at x , and f also vanishes at $p_1, p_2, p_3, q_1, q_2, q_3$.

(iii) Suppose that a conic C is tangent to six lines making a hexagon. Prove Brianchon's Theorem, that the main diagonals meet in a point.

7.9.14. Let $Y \xrightarrow{\pi} \mathbb{P}^d$ be a finite morphism of varieties. Prove that Y is a projective variety. Do this by showing that the global sections of $\mathcal{O}_Y(nH) = \mathcal{O}_Y \otimes_{\mathcal{O}_X} \mathcal{O}_X(nH)$ define a map to projective space whose image is isomorphic to Y .

xfiniteproj

7.9.15. Let N be a 3×2 matrix with variable entries (n_{ij}) , and let $M = (m_1, m_2, m_3)$ be the 1×3 matrix of 2×2 minors of N :

xminors

$$m_1 = n_{21}n_{32} - n_{22}n_{31}, \quad m_2 = -n_{11}n_{32} + n_{12}n_{31}, \quad m_3 = n_{11}n_{22} - n_{12}n_{21}.$$

Let I be the ideal of the polynomial ring $P = \mathbb{C}\{n_{ij}\}$ generated by the minors.

(a) Show that the locus $V(I)$ in \mathbb{A}^6 is irreducible, and that it has dimension 4.

(b) Assume that the locus $X = V(I)$ in $Y = \text{Spec } P$ has scodimension at least 2. Prove that this sequence is exact:

$$0 \rightarrow B^2 \xrightarrow{N} B^3 \xrightarrow{M} B \rightarrow B/I \rightarrow 0.$$

(c) Suppose that the entries of N are homogeneous polynomials in x_0, x_1, x_2 , that for some integers $d_i, i = 1, 2, 3$, the entries in row i have degree d_i . Suppose also that the locus $V(I)$ in \mathbb{P}^2 has dimension zero. Construct an exact sequence that allows you to bound the number of points of $V(I)$.

(d) Check your answer in a particular case, when $d_i = 1$.

7.9.16. Let $f(x, y, z)$ and $g(x, y, z)$ be homogeneous polynomials of degrees m and n , and with no common factor. Let R be the polynomial ring $\mathbb{C}[x, y, z]$, and let $A = R/(f, g)$. Show that the sequence

$$0 \rightarrow R \xrightarrow{(-g, f)} R^2 \xrightarrow{(f, g)} R \rightarrow A \rightarrow 0$$

is exact.

7.9.17. Let $f(x_0, x_1, x_2)$ be an irreducible homogeneous polynomial of degree $2d$, and let Y be the projective double plane $y^2 = f(x_0, x_1, x_2)$. Compute the cohomology $H^q(Y, \mathcal{O}_Y)$.

7.9.18. Let Y be an affine variety with integrally closed coordinate ring B . Let I be an ideal of B generated by two elements u, v , and let X be the locus $V(I)$ in Y . Suppose that $\dim X \leq \dim Y - 2$. Use the fact that $B = \bigcup B_Q$ where Q ranges over prime ideals of codimension 1 to prove that this sequence is exact:

$$0 \rightarrow B \xrightarrow{(v, -u)} B^2 \xrightarrow{(u, v)} B \rightarrow B/I \rightarrow 0.$$

7.9.19. Let I be the ideal of $\mathbb{C}[x_0, x_1, x_2, x_3]$ generated by two homogeneous polynomials f, g , of degrees d, e respectively, and assume that the locus $X = V(I)$ in \mathbb{P}^3 has dimension 1. Let $O = \mathcal{O}_{\mathbb{P}^3}$.

(a) Construct an exact sequence

$$0 \rightarrow O(-d-e) \rightarrow O(-d) \oplus O(-e) \rightarrow O \rightarrow O_X \rightarrow 0.$$

(b) Show that X is a connected subset of \mathbb{P}^3 for the Zariski topology, i.e., that it is not the union of two proper disjoint Zariski-closed subsets.

(c) Determine the genus, assuming that X is a smooth algebraic curve.

7.9.20. A curve Y in \mathbb{P}^3 is a *complete intersection* if the homogeneous prime ideal of $\mathbb{C}[y_0, y_1, y_2, y_3]$ that defines Y is generated by two elements, say $P = (f, g)$. Suppose that this is the case, and that the homogeneous polynomials f and g have degrees r and s , respectively.

(a) Construct an exact sequence

$$0 \rightarrow \mathcal{O}_{\mathbb{P}^3}(-r-s) \rightarrow \mathcal{O}_{\mathbb{P}^3}(-r) \oplus \mathcal{O}_{\mathbb{P}^3}(-s) \rightarrow \mathcal{O}_{\mathbb{P}^3} \rightarrow i_* \mathcal{O}_Y \rightarrow 0$$

(b) Determine the genus of Y .

7.9.21. Let Y be an affine variety with integrally closed coordinate ring B . Let I be an ideal of B generated by two elements u, v , and let X be the locus $V(I)$ in Y . Suppose that $\dim X \leq \dim Y - 2$. Use the fact that $B = \bigcup B_Q$ where Q ranges over prime ideals of codimension 1 to prove that this sequence is exact:

$$0 \rightarrow B \xrightarrow{(v, -u)} B^2 \xrightarrow{(u, v)} B \rightarrow B/I \rightarrow 0.$$

7.9.22. Let I be the ideal of $\mathbb{C}[x_0, x_1, x_2, x_3]$ generated by two homogeneous polynomials f, g , of degrees d, e respectively, and assume that the locus $X = V(I)$ in \mathbb{P}^3 has dimension 1. Let $O = \mathcal{O}_{\mathbb{P}^3}$.

(a) Construct an exact sequence

$$0 \rightarrow O(-d-e) \rightarrow O(-d) \oplus O(-e) \rightarrow O \rightarrow O_X \rightarrow 0.$$

(b) Show that X is a connected subset of \mathbb{P}^3 for the Zariski topology, i.e., that it is not the union of two proper Zariski-closed subsets.

(c) Determine the genus, when X is a smooth algebraic curve.

7.9.23. Let

$$N = \begin{pmatrix} y_{11} & y_{12} \\ y_{21} & y_{22} \\ y_{31} & y_{32} \end{pmatrix}$$

xmi-
norstwo

be a 3×2 matrix whose entries are homogeneous polynomials of degree d in $R = \mathbb{C}[x_0, x_1, x_2]$, and let $M = (m_1, m_2, m_3)$ be the 1×3 matrix of minors

$$m_1 = y_{21}y_{32} - y_{22}y_{31}, \quad m_2 = -y_{11}y_{32} + y_{12}y_{31}, \quad m_3 = y_{11}y_{22} - y_{12}y_{21}.$$

Let I be the ideal of R generated by the minors m_1, m_2, m_3 .

(a) By counting dimensions, prove that if I is the unit ideal of R , the sequence $0 \leftarrow R \xleftarrow{M} R^3 \xleftarrow{N} R^2 \leftarrow 0$ is exact.

(b) Let $X = \mathbb{P}^2$, and suppose that the locus Y of zeros of I in X has dimension zero. Prove that the sequence $0 \leftarrow R/I \leftarrow R \xleftarrow{M} R^3 \xleftarrow{N} R^2 \leftarrow 0$ is exact.

(c) The sequence in (b) corresponds to the following sequence, in which the terms R have been replaced by twisting modules: $0 \leftarrow \mathcal{O}_Y \leftarrow \mathcal{O}_X \xleftarrow{M} \mathcal{O}_X(-2d)^3 \xleftarrow{N} \mathcal{O}_X(-3d)^2 \leftarrow 0$. Use this sequence to determine $h^0(Y, \mathcal{O}_Y)$. Check your work by counting points in some example in which y_{ij} are homogeneous linear polynomials.

7.9.24. (*algebraic version of Bézout's Theorem*) Let f and g be homogeneous polynomials of degrees m and n , respectively, in x, y, z . The algebra $A = \mathbb{C}[x, y, z]/(f, g)$ inherits a grading by degree: $A = A_0 \oplus A_1 \oplus \cdots$, where A_n is the image of the space of homogeneous polynomials of degree n , together with 0. Prove that $\dim A_k = mn$ for all sufficiently large k .

xalgbez

7.9.25. Extend the Bézout theorem to count the intersections of three surfaces in \mathbb{P}^3 . (The problem here comes down to finding a resolution of $\mathcal{O}/(f, g, h)\mathcal{O}$. When you have guessed one, you may be able to use the snake lemma to prove that it is exact.

xextend-
bez

Chapter 8 THE RIEMANN-ROCH THEOREM FOR CURVES

rrcurves

- 8.1 Branched Coverings
- 8.2 Divisors
- 8.3 The Riemann-Roch Theorem
- 8.4 The Birkhoff-Grothendieck Theorem
- 8.5 Differentials
- 8.6 Trace
- 8.7 The Riemann-Roch Theorem II
- 8.8 Using Riemann-Roch

The topic of this chapter is a classical problem of algebraic geometry, to determine the rational functions on a smooth projective curve with given poles. This is can be difficult. The functions whose poles have orders at most r_i at p_i , for $i = 1, \dots, k$, form a vector space, and one is usually happy if one can determine the dimension of that space. The most important tool for determining the dimension is the Riemann-Roch Theorem.

8.1 Branched Coverings

cover-
curve

We begin with a brief look at modules on a smooth curve.

Smooth affine curves were discussed in Chapter 5. An affine curve is smooth if its local rings are valuation rings, or if its coordinate ring is a normal domain. An arbitrary curve is smooth if it has an open covering by smooth affine curves.

Recall that a module over a domain A is torsion-free if its only torsion element is zero (2.6.5). This definition is extended to \mathcal{O} -modules by applying it to affine open sets.

lfree

8.1.1. Lemma. *Let Y be a smooth curve.*

- (i) *A finite \mathcal{O} -module \mathcal{M} is locally free if and only if it is torsion-free.*
- (ii) *An \mathcal{O} -module \mathcal{M} that isn't torsion-free has a nonzero global section.*

proof. (i) We may assume that Y is affine, $Y = \text{Spec } B$, and that \mathcal{M} is the \mathcal{O} -module associated to a B -module M . Let \tilde{B} and \tilde{M} be the localizations of B and M at a point q , respectively. Then \tilde{M} is a finite, torsion-free module over the local ring \tilde{B} . It suffices to show that, for every point q of Y , \tilde{M} is a free \tilde{B} -module (2.6.10). The local ring \tilde{B} is a valuation ring. It is a principal ideal domain because its nonzero ideals are powers of the maximal ideal $\tilde{\mathfrak{m}}$, which is a principal ideal. Every finite, torsion-free module over a principal ideal domain is free.

(ii) If the torsion submodule of \mathcal{M} isn't zero, there will be an affine open subset U of Y , and there will be nonzero elements m in $\mathcal{M}(U)$ and a in $\mathcal{O}(U)$, such that $am = 0$. Let C be the finite set of zeros of a in U , and let $V = Y - C$ be the sopen complement of C in Y . Then a is invertible on the intersection $W = U \cap V$, and since $am = 0$, the restriction of m to W is zero.

The open sets U and V cover Y , and the sheaf property for this covering can be written as an exact sequence

$$0 \rightarrow \mathcal{M}(Y) \rightarrow \mathcal{M}(U) \times \mathcal{M}(V) \xrightarrow{+\rightarrow} \mathcal{M}(W)$$

(Lemma 6.3.11). In this sequence, the section $(m, 0)$ of $\mathcal{M}(U) \times \mathcal{M}(V)$ maps to zero in $\mathcal{M}(W)$. Therefore it is the image of a nonzero global section of \mathcal{M} . \square

8.1.2. Lemma. *Let Y be a smooth curve. Every nonzero ideal \mathcal{I} of \mathcal{O}_Y is a product of powers of maximal ideals of \mathcal{O}_Y : $\mathcal{I} = \mathfrak{m}_1^{e_1} \cdots \mathfrak{m}_k^{e_k}$.*

idealprod-max

proof. This follows for any smooth curve from the case that Y is affine, which is Proposition 5.3.7. \square

We come now the main topic of this section: branched coverings of smooth curves.

An integral morphism $Y \xrightarrow{\pi} X$ of smooth curves will be called a *branched covering*. Chevalley's Finiteness Theorem shows that every morphism of smooth projective curves is a branched covering, unless it maps Y to a point.

Let $Y \rightarrow X$ be a branched covering. The function field K of Y will be a finite extension of the function field F of X . The *degree* of the covering is the degree $[K : F]$ of that field extension. It may also be denoted by $[Y : X]$. If $X' = \text{Spec } A$ is an affine open subset of X , its inverse image Y' will be an affine open subset $Y' = \text{Spec } B$ of Y , and B will be a locally free A -module whose rank is the degree $[Y : X]$ of the covering.

To describe the fibre of a branched covering $Y \xrightarrow{\pi} X$ over a point p of X , we may localize. So we may assume that X and Y are affine, $X = \text{Spec } A$ and $Y = \text{Spec } B$, and that the maximal ideal \mathfrak{m}_p of A at a point p is a principal ideal, generated by an element x of A . If a point q of Y lies over p , the *ramification index* at q , which we denote by e , is defined to be $v_q(x)$, where v_q is the valuation of the function field K corresponding to q . We usually denote the ramification index by e . Then, if y is a local generator for the maximal ideal \mathfrak{m}_q of B at q , we will have

$$x = uy^e$$

where u is a local unit. (A rational function is a *local unit* at a point p if it is a unit in some open neighborhood of p .)

The next lemma follows from Lemma 8.1.2 and the Chinese Remainder Theorem.

8.1.3. Lemma. *Let $Y \xrightarrow{\pi} X$ be a branched covering, with $X = \text{Spec } A$ and $Y = \text{Spec } B$. Let q_1, \dots, q_k be the points of Y that lie over a point p of X , let x be a generator for the maximal ideal \mathfrak{m}_p at p , and let \mathfrak{m}_i and e_i be the maximal ideal and ramification index at q_i , respectively.*

extendedideal-isprod

(i) *The extended ideal $\mathfrak{m}_p B = xB$ is the product ideal $\mathfrak{m}_1^{e_1} \cdots \mathfrak{m}_k^{e_k}$.*

(ii) *Let $\bar{B}_i = B/\mathfrak{m}_i^{e_i}$. The quotient $\bar{B} = B/xB$ is isomorphic to the product $\bar{B}_1 \times \cdots \times \bar{B}_k$.*

(iii) *The degree $[Y : X]$ of the covering is the sum $e_1 + \cdots + e_k$ of the ramification indices at the points q_i . \square*

Points of Y whose ramification indices are greater than one are called *branch points*. We will also call a point p of X a *branch point* of the covering if there is a branch point of Y whose image is p .

8.1.4. Lemma. *A branched covering $Y \rightarrow X$ will have finitely many branch points. If a point p of X isn't a branch point, the fibre over p consists of $n = [Y : X]$ points with ramification indices equal to 1.*

mostpts

proof. This is very simple. We can delete finite sets of points, so we may suppose that X and Y are affine, $X = \text{Spec } A$ and $Y = \text{Spec } B$. Then B is a finite A -module of rank n . Let F and K be the fraction fields of A and B , respectively, and let β be an element of B that generates the field extension K/F . Then $A[\beta] \subset B$, and since these two rings have the same fraction field, there will be a nonzero element $s \in A$ such that $A_s[\beta] = B_s$. We may suppose that $B = A[\beta]$. Let g be the monic irreducible polynomial for β over A . The discriminant of g is not the zero ideal (1.7.19). Then for all but finitely many points p of X , the discriminant will be nonzero, and there will be n points of Y over p with ramification indices equal to 1. \square

8.1.5. Corollary. *A branched covering $Y \xrightarrow{\pi} X$ of degree one is an isomorphism.*

degonei-som

proof. When $[Y : X] = 1$, the function fields of Y and X are equal. Then, because $Y \rightarrow X$ is an integral morphism and X is normal, $Y = X$. \square

figure: a branched covering???

(8.1.6) local analytic structure

locanstr

The local analytic structure of a branched covering $Y \xrightarrow{\pi} X$ in the classical topology is very simple. We explain it here because it is helpful for intuition, and it can also be useful.

yeth-
roottwo

8.1.7. Proposition. *In the classical topology, Y is locally isomorphic to the e -th root covering $y^e = x$.*

proof. Let q be a point of Y , let p be its image in X , let x and z be local generators for the maximal ideals \mathfrak{m}_p of \mathcal{O}_X at p , and \mathfrak{m}_q of \mathcal{O}_Y at q , respectively. Let $e = v_q(x)$ be the ramification index at q . Then x has the form uz^e , where u is a local unit at q . In a neighborhood of q in the classical topology, u will have an analytic e -th root w . The element $y = wz$ also generates \mathfrak{m}_q locally, and $x = y^e$. It follows from the implicit function theorem that x and y are local analytic coordinate functions on X and Y (see the proof of (1.8.11)). \square

pprimeap-
proachesp

8.1.8. Corollary. *Let $Y \xrightarrow{\pi} X$ be a branched covering, let $\{q_1, \dots, q_k\}$ be the fibre over a point p of X , and let e_i be the ramification index at q_i . As a point p' of X approaches p , e_i points of the fibre over p' approach q_i .* \square

workonX

8.1.9. Notation. When considering a branched covering $Y \xrightarrow{\pi} X$ of smooth curves, we will often pass between an \mathcal{O}_Y -module \mathcal{M} and its direct image $\pi_*\mathcal{M}$, and it will be convenient to work primarily on X . Recall that if Y' is the inverse image of an open subset X' of X , then

$$[\pi_*\mathcal{M}](X') = \mathcal{M}(Y')$$

One can think of the direct image $\pi_*\mathcal{M}$ as working with \mathcal{M} , but looking only at open subsets Y' that are inverse images of open subsets X' of X . If we look only at such subsets, the only significant difference between \mathcal{M} and its direct image will be that the $\mathcal{O}_Y(Y')$ -module $\mathcal{M}(Y')$ is made into an $\mathcal{O}_X(X')$ -module by restriction of scalars.

To simplify notation, we will often drop the symbol π_* , and write \mathcal{M} instead of $\pi_*\mathcal{M}$. If X' is an open subset of X , $\mathcal{M}(X')$ will stand for $[\pi_*\mathcal{M}](X') = \mathcal{M}(\pi^{-1}X')$. When denoting the direct image of an \mathcal{O}_Y -module \mathcal{M} by the same symbol \mathcal{M} , we may refer to it as an \mathcal{O}_X -module. In accordance with this convention, we may also write \mathcal{O}_Y for $\pi_*\mathcal{O}_Y$, but we must be careful to include the subscript Y .

This abbreviation is analogous to the one used for restriction of scalars in a module. When $A \rightarrow B$ is an algebra homomorphism, the A -module obtained from a B -module M by restriction of scalars is usually denoted by the same letter M . \square

8.1.10. Lemma. *Let $Y \rightarrow X$ be a branched covering of smooth curves.*

BrankArank

- (i) *A finite \mathcal{O}_Y -module \mathcal{M} is a torsion \mathcal{O}_Y -module if and only if it is a torsion \mathcal{O}_X -module.*
- (ii) *A finite \mathcal{O}_Y -module \mathcal{M} is a locally free \mathcal{O}_Y -module if and only if it is a locally free \mathcal{O}_X -module. If \mathcal{M} is a locally free \mathcal{O}_Y -module of rank r , then its rank as \mathcal{O}_X -module will be nr , where $n = [Y : X]$ is the degree of the covering.* \square

zerospoles

(8.1.11) the module of homomorphisms

We begin by discussing homomorphisms of modules over a ring.

Let M and N be modules over a noetherian ring A . The set of homomorphisms $M \rightarrow N$ is usually denoted by $\text{Hom}_A(M, N)$. It becomes an A -module with some fairly obvious laws of composition: If φ and ψ are homomorphisms and a is an element of A , then $\varphi + \psi$ and $a\varphi$ are defined by

homis-
module

$$(8.1.12) \quad [\varphi + \psi](m) = \varphi(m) + \psi(m) \quad \text{and} \quad [a\varphi](m) = a\varphi(m)$$

Because φ is a module homomorphism, we also have $\varphi(m_1 + m_2) = \varphi(m_1) + \varphi(m_2)$ and $a\varphi(m) = \varphi(am)$.

Nequal-
sHom

8.1.13. Lemma. (i) *An A -module N is canonically isomorphic to $\text{Hom}_A(A, N)$. The homomorphism $A \xrightarrow{\varphi} N$ that corresponds to an element x of N is multiplication by x : $\varphi(a) = ax$. The element of N that corresponds to a homomorphism $A \xrightarrow{\varphi} N$ is $x = \varphi(1)$.*

(ii) *$\text{Hom}_A(A^k, N)$ is isomorphic to N^k , and $\text{Hom}_A(A^k, A^\ell)$ is isomorphic to the module $A^{\ell \times k}$ of $k \times \ell$ A -matrices.* \square

A presentation of an A -module M is an exact sequence of the form $A^\ell \rightarrow A^k \rightarrow M \rightarrow 0$. Every finite module over a noetherian ring A has such a presentation.

8.1.14. Lemma.

homfinite

(i) The functor Hom_A is a left exact and **contravariant** in the first variable. For any A -module N , an exact sequence $M_1 \rightarrow M_2 \rightarrow M_3 \rightarrow 0$ of A -modules induces an exact sequence

$$0 \rightarrow \text{Hom}_A(M_3, N) \rightarrow \text{Hom}_A(M_2, N) \rightarrow \text{Hom}_A(M_1, N)$$

(ii) The functor Hom_A is a left exact and **covariant** in the second variable. For any A -module M , an exact sequence $0 \rightarrow N_1 \rightarrow N_2 \rightarrow N_3$ of A -modules induces an exact sequence

$$0 \rightarrow \text{Hom}_A(M, N_1) \rightarrow \text{Hom}_A(M, N_2) \rightarrow \text{Hom}_A(M, N_3) \quad \square$$

8.1.15. Corollary. If M and N are finite A -modules over a noetherian ring A , then $\text{Hom}_A(M, N)$ is a finite A -module.

homfinitetwo

This follows when part (i) of the lemma is applied to a presentation of M . □

The module Hom is compatible with localization:

8.1.16. Lemma. Let M and N be modules over a noetherian domain A , and suppose that M is a finite module. Let S be a multiplicative system in A . The localization $S^{-1}\text{Hom}_A(M, N)$ is canonically isomorphic to $\text{Hom}_{S^{-1}A}(S^{-1}M, S^{-1}N)$.

localize-Hom

proof. We choose a presentation $A^\ell \rightarrow A^k \rightarrow M \rightarrow 0$ of the A -module M . Its localization, which is $(S^{-1}A)^\ell \rightarrow (S^{-1}A)^k \rightarrow S^{-1}M \rightarrow 0$ is a presentation of the $S^{-1}A$ -module $S^{-1}M$. The sequence

$$0 \rightarrow \text{Hom}_A(M, N) \rightarrow \text{Hom}_A(A^k, N) \rightarrow \text{Hom}_A(A^\ell, N)$$

is exact, as is its localization. So it suffices to prove the lemma in the case that $M = A$. It is true in that case. □

This lemma shows that, when \mathcal{M} and \mathcal{N} are finite \mathcal{O} -modules on a variety X , there is an \mathcal{O} -module of homomorphisms $\mathcal{M} \rightarrow \mathcal{N}$. This \mathcal{O} -module is usually denoted by $\underline{\text{Hom}}_{\mathcal{O}}(\mathcal{M}, \mathcal{N})$. If $U = \text{Spec } A$ is an affine open set, $M = \mathcal{M}(U)$ and $N = \mathcal{N}(U)$, the module of sections of $\underline{\text{Hom}}_{\mathcal{O}}(\mathcal{M}, \mathcal{N})$ on U is the A -module $\text{Hom}_A(M, N)$. We use the underlined symbol $\underline{\text{Hom}}$ here because the vector space of homomorphisms $\mathcal{M} \rightarrow \mathcal{N}$ defined on all of X , which is the space of global sections of $\underline{\text{Hom}}_{\mathcal{O}}(\mathcal{M}, \mathcal{N})$, is customarily denoted by $\text{Hom}_{\mathcal{O}}(\mathcal{M}, \mathcal{N})$.

The analogues of Lemma 8.1.13 and lemma 8.1.14 are true for $\underline{\text{Hom}}$:

8.1.17. Corollary. (i) An \mathcal{O} -module \mathcal{M} on a smooth curve Y is isomorphic to $\underline{\text{Hom}}_{\mathcal{O}}(\mathcal{O}, \mathcal{M})$.

leftexco

(ii) The functor $\underline{\text{Hom}}$ is left exact and **contravariant** in the first variable, and it is left exact and **covariant** in the first variable. □

Notation. The notation $\text{Hom}_A(M, N)$ is cumbersome. It seems permissible to drop the symbol Hom , and to write ${}_A(M, N)$ for $\text{Hom}_A(M, N)$. Similarly, if \mathcal{M} and \mathcal{M} are \mathcal{O} -modules on a variety X , we will write ${}_{\mathcal{O}}(\mathcal{M}, \mathcal{N})$ or ${}_X(\mathcal{M}, \mathcal{N})$ for $\underline{\text{Hom}}_{\mathcal{O}}(\mathcal{M}, \mathcal{N})$.

(8.1.18) the dual module

dualmod

The *dual module* \mathcal{M}^* of a locally free \mathcal{O} -module \mathcal{M} is the \mathcal{O} -module ${}_{\mathcal{O}}(\mathcal{M}, \mathcal{O})$ of \mathcal{O} -module homomorphisms $\mathcal{M} \rightarrow \mathcal{O}$. A section of \mathcal{M}^* on an open set U is a $\mathcal{O}(U)$ -module homomorphism $\mathcal{M}(U) \rightarrow \mathcal{O}(U)$.

The dualizing operation is contravariant. A homomorphism $\mathcal{M} \rightarrow \mathcal{N}$ of locally free \mathcal{O} -modules induces a homomorphism $\mathcal{M}^* \leftarrow \mathcal{N}^*$.

If \mathcal{M} is a free module with basis v_1, \dots, v_k , then \mathcal{M}^* will also be free, with the dual basis v_i^* defined by $v_i^*(v_i) = 1$ and $v_i^*(v_j) = 0$ if $i \neq j$. Therefore, when \mathcal{M} is locally free, \mathcal{M}^* is also locally free. The dual \mathcal{O}^* of the structure sheaf \mathcal{O} is the module \mathcal{O} itself. If \mathcal{M} and \mathcal{N} are locally free \mathcal{O} -modules, the dual $(\mathcal{M} \otimes_{\mathcal{O}} \mathcal{N})^*$ is isomorphic to the tensor product $\mathcal{M}^* \otimes_{\mathcal{O}} \mathcal{N}^*$.

There is a canonical \mathcal{O} -bilinear map $\mathcal{M}^* \times \mathcal{M} \rightarrow \mathcal{O}$. If μ and m are sections of \mathcal{M}^* and \mathcal{M} , respectively, the bilinear map evaluates μ at m : $\langle \mu, m \rangle = \mu(m)$.

bidualm **8.1.19. Corollary. (i)** A locally free \mathcal{O} -module \mathcal{M} is canonically isomorphic to its bidual: $(\mathcal{M}^*)^* \approx \mathcal{M}$.
(ii) If \mathcal{M} and \mathcal{N} are locally free \mathcal{O} -modules, $\mathcal{M}^* \otimes_{\mathcal{O}} \mathcal{N}^*$ is isomorphic to $(\mathcal{N} \otimes_{\mathcal{O}} \mathcal{M})^*$. \square

dualseq **8.1.20. Proposition.** Let \mathcal{O} be the structure sheaf on a variety X .

(i) Let $\mathcal{P} \xrightarrow{f} \mathcal{N} \xrightarrow{g} \mathcal{P}$ be homomorphisms of \mathcal{O} -modules whose composition gf is the identity map on \mathcal{P} . Then \mathcal{N} is the direct sum of the image of f , which is isomorphic to \mathcal{P} , and the kernel \mathcal{K} of g : $\mathcal{N} \approx \mathcal{P} \oplus \mathcal{K}$.

(ii) Let $g : \mathcal{N} \rightarrow \mathcal{P}$ be a surjective homomorphism \mathcal{O} -modules, and suppose that \mathcal{P} is a free module. If the map $H^0(\mathcal{N}) \rightarrow H^0(\mathcal{P})$ of global sections is surjective, the sequence splits: \mathcal{N} is isomorphic to the direct sum $\mathcal{M} \oplus \mathcal{P}$.

(iii) Let $0 \rightarrow \mathcal{M} \rightarrow \mathcal{N} \rightarrow \mathcal{P} \rightarrow 0$ be an exact sequence of \mathcal{O} -modules. If \mathcal{P} is locally free, the dual modules form an exact sequence $0 \rightarrow \mathcal{P}^* \rightarrow \mathcal{N}^* \rightarrow \mathcal{M}^* \rightarrow 0$.

proof. **(i)** This follows from the analogous statement about modules over a ring.

(ii) Let $\{p_i\}$ be a basis of global sections of \mathcal{P} , let v_i be global sections of \mathcal{N} such that $g(v_i) = p_i$, and let f be the map $f : \mathcal{P} \rightarrow \mathcal{N}$ defined by $f(p_i) = v_i$. Then fg is the identity map on \mathcal{P} .

(iii) The sequence $0 \rightarrow \mathcal{P}^* \rightarrow \mathcal{N}^* \rightarrow \mathcal{M}^* \rightarrow 0$ is exact whether or not the modules are locally free (8.1.14(ii)). The zero on the right comes from the fact that, when \mathcal{P} is locally free, it is free on some affine covering, so the given sequence splits locally. \square

8.2 Divisors

divtwo

A *divisor* on a smooth curve Y is a finite integer combination of points:

$$D = r_1q_1 + \cdots + r_kq_k$$

with $r_i \in \mathbb{Z}$. The terms r_iq_i whose integer coefficients r_i are zero can be omitted or not, as desired.

The *support* of the divisor D is the set of points q_i of Y such that $r_i \neq 0$. The *degree* of D is the sum $r_1 + \cdots + r_k$ of the coefficients.

Let Y' be an open subset of Y . The *restriction* of a divisor $D = r_1q_1 + \cdots + r_kq_k$ to Y' is the divisor on Y' obtained from D by deleting points that aren't in Y' . For example, if $D = q$, the restriction of D to Y' is q when $q \in Y'$, and is zero when $q \notin Y'$.

A divisor $D = \sum r_iq_i$ is *effective* if all of its coefficients r_i are non-negative, and if Y' is an open subset of Y , D is *effective on Y'* if its restriction to Y' is effective – if $r_i \geq 0$ for every i such that q_i is a point of Y' . Let $D = \sum r_iq_i$ and $E = \sum s_iq_i$ be divisors. We may write $D \leq E$ if $r_i \leq s_i$ for all i , or if $E - D$ is effective. Thus $D \geq 0$ if $r_i \geq 0$ for all i , i.e., if D is effective.

divfn (8.2.1) the divisor of a function

Let f be a rational function on a smooth curve Y . The *divisor of f* is

$$\operatorname{div}(f) = \sum_{q \in Y} v_q(f)q$$

where, as usual, v_q denotes the valuation of K that corresponds to the point q of Y .

The divisor of f is written here as a sum over all points q , but it becomes a finite sum when we disregard terms with coefficient zero, because f has finitely many zeros and poles. The coefficients will be zero at all other points.

The map

$$K^\times \rightarrow (\operatorname{divisors})^+$$

that sends a rational function to its divisor is a homomorphism from the multiplicative group K^\times of nonzero elements of K to the additive group of divisors:

$$\operatorname{div}(fg) = \operatorname{div}(f) + \operatorname{div}(g)$$

As before, a rational function f has a *zero of order* $r > 0$ at q if $v_q(f) = r$, and it has a *pole of order* r at q if $v_q(f) = -r$. Thus the divisor of f is the difference of two effective divisors:

$$\operatorname{div}(f) = \operatorname{zeros}(f) - \operatorname{poles}(f)$$

A rational function f is regular on Y if and only if $\operatorname{div}(f)$ is effective – if and only if $\operatorname{poles}(f) = 0$.

The divisor of a rational function is a *principal divisor*, and two divisors D and E are *linearly equivalent* if their difference $D - E$ is a principal divisor. For instance, the divisors $\operatorname{zeros}(f)$ and $\operatorname{poles}(f)$ of a rational function f are linearly equivalent.

8.2.2. Lemma. *Let f be a rational function on a smooth curve Y . For all complex numbers c , the divisors of zeros of $f - c$, which are the level sets of f , are linearly equivalent.* levelsets

proof. The functions $f - c$ have the same poles as f . □

(8.2.3) invertible modules invertmod

An *invertible* \mathcal{O} -module is a locally free module of rank one – a module that is isomorphic to the free module \mathcal{O} in a neighborhood of any point. The tensor product $\mathcal{L} \otimes_{\mathcal{O}} \mathcal{M}$ of invertible modules is invertible. The dual \mathcal{L}^* of an invertible module \mathcal{L} is invertible.

Part (i) of the next lemma explains the adjective ‘invertible’.

8.2.4. Lemma. *Let \mathcal{L} be an invertible \mathcal{O} -module.* inverse-

(i) *Let \mathcal{L}^* be the dual module. The canonical map $\mathcal{L}^* \otimes_{\mathcal{O}} \mathcal{L} \rightarrow \mathcal{O}$ defined by $\gamma \otimes \alpha \mapsto \gamma(\alpha)$ is an isomorphism.* mod

(ii) *The map $\mathcal{O} \rightarrow \mathcal{O}(\mathcal{L}, \mathcal{L})$ that sends a regular function α to multiplication by α is an isomorphism.*

(iii) *Every nonzero homomorphism $\mathcal{L} \xrightarrow{\varphi} \mathcal{M}$ to a locally free module \mathcal{M} is injective.*

proof. (i),(ii) It is enough to verify these assertions in the case that \mathcal{L} is free, isomorphic to \mathcal{O} , in which case they are clear.

(iii) The problem is local, so we may assume that the variety is affine, say $Y = \operatorname{Spec} A$, and that \mathcal{L} and \mathcal{M} are free. Then φ becomes a nonzero homomorphism $A \rightarrow A^k$. Such a homomorphism is injective because A is a domain. □

(8.2.5) the module $\mathcal{O}(D)$ mod- uleOD

To analyze functions with given poles on a smooth curve Y , we associate an invertible \mathcal{O} -module $\mathcal{O}(D)$ to a divisor D . The nonzero sections of $\mathcal{O}(D)$ on an open subset V of Y are the rational functions f such that the the divisor $\operatorname{div}(f) + D$ is effective on V – such that its restriction to V is effective.

Thus, when D is effective, the global sections of $\mathcal{O}(D)$ are the rational functions with poles bounded by D . They are the solutions of the classical problem that was mentioned at the beginning of the chapter.

$$(8.2.6) \quad [\mathcal{O}(D)](V) = \{f \mid \operatorname{div}(f) + D \text{ is effective on } V\} \cup \{0\} \quad \text{ODV}$$

Points that aren’t in V impose no conditions on the sections of $\mathcal{O}(D)$ on V . A section on V can have arbitrary zeros or poles at points not in V .

When D is an effective divisor, a rational function f is a global section of $\mathcal{O}(D)$ if $\operatorname{poles}(f) \leq D$.

Say that $D = \sum r_i q_i$. If q_i is a point of an open set V and if $r_i > 0$, a section of $\mathcal{O}(D)$ on V may have a pole of order at most r_i at q_i , and if $r_i < 0$ a section must have a zero of order at least $-r_i$ at q_i . For example, the module $\mathcal{O}(-q)$ is the maximal ideal \mathfrak{m}_q . The sections of $\mathcal{O}(-q)$ on an open set V that contains q are the regular functions on V that are zero at q . Similarly, the sections of $\mathcal{O}(q)$ on an open set V that contains q are the rational functions that have a pole of order at most 1 at q and are regular at every other point of V . The sections of $\mathcal{O}(-q)$ and of $\mathcal{O}(q)$ on an open set V that doesn’t contain p are the regular functions on V .

The fact that a section of $\mathcal{O}(D)$ is allowed to have a pole at q_i if $r_i > 0$ contrasts with the divisor of a function. If $\operatorname{div}(f) = \sum r_i q_i$, then $r_i > 0$ means that f has a zero at q_i . Thus, if $\operatorname{div}(f) = D$, then f will be a global section of $\mathcal{O}(-D)$.

LisOD **8.2.7. Proposition.** Let D and E be divisors on a smooth curve Y .

(i) The map $\mathcal{O}(D) \otimes_{\mathcal{O}} \mathcal{O}(E) \rightarrow \mathcal{O}(D+E)$ that sends $f \otimes g$ to the product fg is an isomorphism.

(ii) The dual module $\mathcal{O}(D)^*$ is $\mathcal{O}(-D)$.

(iii) $\mathcal{O}(D) \subset \mathcal{O}(E)$ if and only if $E - D$ is effective.

proof. We may assume that Y is affine and that the supports of D and E contain at most one point: $D = rp$ and $E = sp$. We may also assume that the maximal ideal at p is a principal ideal, generated by an element x . Then $\mathcal{O}(D)$, $\mathcal{O}(-D)$, $\mathcal{O}(E)$, and $\mathcal{O}(D + E)$ have bases x^r , x^{-r} , x^s and x^{r+s} , respectively. \square

limODK **8.2.8. Corollary** The union of the modules $\mathcal{O}(D)$ is the function field module \mathcal{K} . \square

idealOD **8.2.9. Corollary.** Let Y be a smooth curve, and let $\mathfrak{m}_1, \dots, \mathfrak{m}_k$ be the maximal ideals at points q_1, \dots, q_k of Y . The product ideal $\mathcal{I} = \mathfrak{m}_1^{r_1} \cdots \mathfrak{m}_k^{r_k}$ of \mathcal{O}_Y is equal to $\mathcal{O}_Y(-D)$, where D is the effective divisor $\sum r_i q_i$. Thus the nonzero ideals of \mathcal{O}_Y correspond bijectively to divisors $-D$, where D is effective. \square

A module of the form $\mathcal{O}(D)$ is equal to \mathcal{O} on the open complement of the support of D . Therefore, when we localize by forming the tensor product $\mathcal{O}(D) \otimes_{\mathcal{O}} \mathcal{K}$ with the function field module \mathcal{K} , we get \mathcal{K} . Since an invertible module \mathcal{L} is isomorphic to \mathcal{O} on an open set, the localization $\mathcal{L}_{\mathcal{K}} = \mathcal{L} \otimes_{\mathcal{O}} \mathcal{K}$ is a one dimensional K -vector space, but without a chosen basis. As the next proposition shows, this is the only difference between an invertible module \mathcal{L} and a module of the form $\mathcal{O}(D)$.

LD **Notation.** Let \mathcal{L} be an invertible module and let D be a divisor. We denote by $\mathcal{L}(D)$ the invertible module $\mathcal{L} \otimes_{\mathcal{O}} \mathcal{O}(D)$. If $\mathcal{L} \approx \mathcal{O}(D)$, the *degree* of \mathcal{L} is defined to be the degree of D .

invertOD **8.2.10. Proposition.** Every invertible \mathcal{O} -module \mathcal{L} is isomorphic to a module of the form $\mathcal{O}(D)$.

proof. Since the function field module \mathcal{K} of Y is the union $\mathcal{K} = \bigcup \mathcal{O}(D)$, we also have $\mathcal{L}_{\mathcal{K}} = \bigcup \mathcal{L}(D)$, where $\mathcal{L}(D)$ denotes the tensor product $\mathcal{L} \otimes_{\mathcal{O}} \mathcal{O}(D)$. A nonzero global section α of $\mathcal{L}_{\mathcal{K}}$ will be a global section of $\mathcal{L}(D)$ for some D . It will define a map $\mathcal{O} \xrightarrow{\alpha} \mathcal{L}(D)$. Passing to duals, $\mathcal{L}(D)^* = \mathcal{L}^* \otimes_{\mathcal{O}} \mathcal{O}(D)^* \approx \mathcal{L}^* \otimes_{\mathcal{O}} \mathcal{O}(-D) \approx \mathcal{L}^*(-D)$. The dual of the map defined by a nonzero global section α isn't zero and therefore it is an injective map $\mathcal{L}^*(-D) \rightarrow \mathcal{O}$, whose image is an ideal of \mathcal{O} . So $\mathcal{L}^*(-D)$ is isomorphic to $\mathcal{O}(-E)$ for some effective divisor E (8.2.9). Therefore \mathcal{L}^* is isomorphic to $\mathcal{O}(D - E)$. Dualizing once more, \mathcal{L} is isomorphic to $\mathcal{O}(E - D)$. \square

CLD **8.2.11. Proposition.** Let $\mathcal{L} \subset \mathcal{M}$ be an inclusion of invertible \mathcal{O} -modules. Then $\mathcal{M} = \mathcal{L}(E)$ for some effective divisor E .

proof. Since $\mathcal{L} \subset \mathcal{M}$, $\mathcal{L} \otimes_{\mathcal{O}} \mathcal{M}^* \subset \mathcal{M} \otimes_{\mathcal{O}} \mathcal{M}^* = \mathcal{O}$. Therefore $\mathcal{L} \otimes_{\mathcal{O}} \mathcal{M}^* = \mathcal{O}(-E)$ for some effective divisor E (8.2.9), and $\mathcal{L} = \mathcal{M}(-E)$. \square

It is important to note that, though every invertible module \mathcal{L} is isomorphic to one of the form $\mathcal{O}(D)$, the divisor D isn't uniquely determined by \mathcal{M} . If D and E are divisors, $\mathcal{O}(D)$ is a submodule of $\mathcal{O}(E)$ only when $E - D$ is effective. But as the next proposition explains, there may be injective homomorphisms from $\mathcal{O}(D)$ to $\mathcal{O}(E)$ that aren't inclusions.

mapOD-toOE **8.2.12. Proposition.** Let D and E be divisors on a smooth curve Y . Multiplication by a rational function f such that $\text{div}(f) + E - D \geq 0$ defines a homomorphism of \mathcal{O} -modules $\mathcal{O}(D) \rightarrow \mathcal{O}(E)$, and every homomorphism $\mathcal{O}(D) \rightarrow \mathcal{O}(E)$ is multiplication by such a function.

proof. For any \mathcal{O} -module \mathcal{M} , a homomorphism $\mathcal{O} \rightarrow \mathcal{M}$ is multiplication by a global section of \mathcal{M} (6.4.6). Then a homomorphism $\mathcal{O} \rightarrow \mathcal{O}(E - D)$ will be multiplication by a rational function f such that $\text{div}(f) + E - D \geq 0$. If f is such a function, one obtains a homomorphism $\mathcal{O}(D) \rightarrow \mathcal{O}(E)$ by tensoring with $\mathcal{O}(D)$. \square

ODOE **8.2.13. Corollary.**

(i) The modules $\mathcal{O}(D)$ and $\mathcal{O}(E)$ are isomorphic if and only if the divisors D and E are linearly equivalent.

(ii) Let f be a rational function on Y , and let $D = \text{div}(f)$. Multiplication by f defines an isomorphism $\mathcal{O}(D) \rightarrow \mathcal{O}$. \square

8.3 The Riemann-Roch Theorem

Let Y be a smooth projective curve. In Chapter 7, we learned that, when \mathcal{M} is a finite \mathcal{O}_Y -module, the cohomology $H^q(Y, \mathcal{M})$ is a finite-dimensional vector space for all q , and is zero if $q \neq 0, 1$. As before, we denote the dimension of the space $H^q(Y, \mathcal{M})$ by $\mathbf{h}^q \mathcal{M}$ or, if there is ambiguity about the variety, by $\mathbf{h}^q(Y, \mathcal{M})$.

The Euler characteristic (7.6.5) of a finite \mathcal{O} -module \mathcal{M} is

$$(8.3.1) \quad \chi(\mathcal{M}) = \mathbf{h}^0 \mathcal{M} - \mathbf{h}^1 \mathcal{M}$$

In particular,

$$\chi(\mathcal{O}_Y) = \mathbf{h}^0 \mathcal{O}_Y - \mathbf{h}^1 \mathcal{O}_Y$$

The dimension $\mathbf{h}^1 \mathcal{O}_Y$ is the *arithmetic genus* of Y . The arithmetic genus is denoted by p_a , as for plane curves (refcohplanecurve). We will see below, in (8.3.10)(iv), that $\mathbf{h}^0 \mathcal{O}_Y = 1$. So

$$(8.3.2) \quad \chi(\mathcal{O}_Y) = 1 - p_a$$

8.3.3. Riemann-Roch Theorem (version 1). Let $D = \sum r_i p_i$ be a divisor on a smooth projective curve Y . Then

$$\chi(\mathcal{O}(D)) = \chi(\mathcal{O}) + \deg D \quad (= \deg D + 1 - p_a)$$

proof. We analyze the effect on cohomology when a divisor is changed by adding or subtracting a point. We do this by inspecting the inclusion $\mathcal{O}(D-p) \subset \mathcal{O}(D)$. Let ϵ be the cokernel of the inclusion map, so that there is a short exact sequence

$$(8.3.4) \quad 0 \rightarrow \mathcal{O}(D-p) \rightarrow \mathcal{O}(D) \rightarrow \epsilon \rightarrow 0$$

in which ϵ is a one-dimensional vector space supported at p . This sequence can be obtained by tensoring the sequence

$$(8.3.5) \quad 0 \rightarrow \mathfrak{m}_p \rightarrow \mathcal{O} \rightarrow \kappa_p \rightarrow 0$$

with the invertible module $\mathcal{O}(D)$, because \mathfrak{m}_p is isomorphic to $\mathcal{O}(-p)$.

Since ϵ is a one-dimensional module supported at p , $\mathbf{h}^0 \epsilon = 1$, and $\mathbf{h}^1 \epsilon = 0$. Let's denote the one-dimensional vector space $H^0(Y, \epsilon)$ (which isn't very different from ϵ itself) by $[1]$. The cohomology sequence associated to (8.3.4) is then

$$(8.3.6) \quad 0 \rightarrow H^0(Y, \mathcal{O}(D-p)) \rightarrow H^0(Y, \mathcal{O}(D)) \xrightarrow{\gamma} [1] \xrightarrow{\delta} H^1(Y, \mathcal{O}(D-p)) \rightarrow H^1(Y, \mathcal{O}(D)) \rightarrow 0$$

In this exact sequence, one of the two maps, γ or δ , must be zero. Either

(1) γ is zero and δ is injective. In this case

$$\mathbf{h}^0 \mathcal{O}(D-p) = \mathbf{h}^0 \mathcal{O}(D) \quad \text{and} \quad \mathbf{h}^1 \mathcal{O}(D-p) = \mathbf{h}^1 \mathcal{O}(D) + 1, \quad \text{or}$$

(2) δ is zero and γ is surjective, in which case

$$\mathbf{h}^0 \mathcal{O}(D-p) = \mathbf{h}^0 \mathcal{O}(D) - 1 \quad \text{and} \quad \mathbf{h}^1 \mathcal{O}(D-p) = \mathbf{h}^1 \mathcal{O}(D)$$

In either case,

$$(8.3.7) \quad \chi(\mathcal{O}(D)) = \chi(\mathcal{O}(D-p)) + 1$$

Also, $\deg D = \deg(D-p) + 1$. The Riemann-Roch theorem follows, because we can get from \mathcal{O} to $\mathcal{O}(D)$ by a finite number of operations, each of which changes the divisor by adding or subtracting a point. \square

The Riemann-Roch Theorem can be written in terms of an invertible module. Recall that the degree of an invertible module \mathcal{L} is the degree of a divisor D such that $\mathcal{L} \approx \mathcal{O}(D)$.

rrone

chicurve

chi-
curvetwo

RRcurve

addpoint

kappaseq

add-
pointtwo

chichange

RRforL **8.3.8. Corollary.** Let \mathcal{L} be an invertible \mathcal{O} -module on a smooth projective curve Y . Then $\chi(\mathcal{L}) = \deg \mathcal{L} + 1 - p_a$. \square

Because $\mathbf{h}^0 \geq \mathbf{h}^0 - \mathbf{h}^1 = \chi$, this version of the Riemann-Roch Theorem gives reasonably good control of H^0 . It is less useful for controlling H^1 . To do that, one wants the full Riemann-Roch Theorem, which is in Section 8.7. It requires some preparation. However, the version above has important consequences:

onepole **8.3.9. Corollary.** Let p be a point of a smooth projective curve Y . The dimension $\mathbf{h}^0(Y, \mathcal{O}(np))$ tends to infinity with n . Therefore there exist rational functions with a pole of large order at p and no other poles.

proof. When we change the module $\mathcal{O}(np)$ to $\mathcal{O}((n+1)p)$, then, as we saw above, either \mathbf{h}^0 increases or \mathbf{h}^1 decreases. Since $H^1(Y, \mathcal{O}(np))$ is finite-dimensional, the second possibility can occur only finitely many times. \square

RRcor **8.3.10. Corollary.** Let Y be a smooth projective curve.

(i) The divisor of a rational function on Y has degree zero: The number of zeros is equal to the number of poles.

(ii) Linearly equivalent divisors on Y have equal degrees.

(iii) A nonconstant rational function on Y takes every value, including infinity, the same number of times.

(iv) A rational function on Y that is regular at every point of Y is a constant: $H^0(Y, \mathcal{O}) = \mathbb{C}$.

(v) Let D be a divisor on Y . If $\deg D \geq p_a$, then $\mathbf{h}^0 \mathcal{O}(D) > 0$. If $\mathbf{h}^0 \mathcal{O}(D) > 0$, then $\deg D \geq 0$.

proof. (i) Let f be a nonzero rational function and let $D = \text{div}(f)$. Multiplication by f defines an isomorphism $\mathcal{O}(D) \rightarrow \mathcal{O}$, so $\chi(\mathcal{O}(D)) = \chi(\mathcal{O})$. On the other hand, by Riemann-Roch, $\chi(\mathcal{O}(D)) = \chi(\mathcal{O}) + \deg D$. Therefore $\deg D = 0$.

(ii) If two divisors D and E are linearly equivalent, say $D - E = \text{div}(f)$, then $D - E$ has degree zero, and $\deg D = \deg E$.

(iii) The zeros of the functions $f - c$ are linearly equivalent to the poles of f .

(iv) According to (iii), a nonconstant function must have a pole.

(v) If $\deg D \geq p_a$, then $\chi = \deg D + 1 - p_a \geq 1$, and $\mathbf{h}^0 \geq \mathbf{h}^0 - \mathbf{h}^1 = \chi$. If $\mathcal{O}(D)$ has a nonzero global section f , a rational function such that $\text{div}(f) + D = E$ is effective, then $\deg E \geq 0$. Since the degree of $\text{div}(f)$ is zero, $\deg D \geq 0$. \square

curveconn **8.3.11. Theorem.** With its classical topology, a smooth projective curve Y is a connected, compact, orientable two-dimensional manifold.

proof. We prove connectedness here. All other points have been discussed before (Theorem 1.8.20). A nonempty topological space is connected if it isn't the union of two disjoint, nonempty, closed subsets. Suppose that, in the classical topology, Y is the union of disjoint, nonempty closed subsets Y_1 and Y_2 . Both Y_1 and Y_2 will be compact manifolds. Let q be a point of Y_1 . Corollary 8.3.9 shows that there is a nonconstant rational function f whose only pole is at q . Then f will be a regular function on the complement of q . It will be an analytic function on the compact manifold Y_2 .

For review: For any point q of Y , Y can be represented as a branched covering of the projective line \mathbb{P}^1 that is unramified at q . Then a small neighborhood V of q in Y maps bijectively to an neighborhood U of its image p in \mathbb{P}^1 . To say that f is analytic means that the function on V that corresponds to f is an analytic function of one variable on U .

The maximum principle for analytic functions asserts that a nonconstant analytic function on an open region of the complex plane has no maximal absolute value in the region. This applies to the neighborhood U of p , and also to the neighborhood V of q . Consequently, if f isn't constant, $|f(q)|$ cannot be a maximum value of f . Since q is arbitrary, f cannot have a maximum on Y_2 . On the other hand, since Y_2 is compact, a continuous function does have a maximum. So f must be constant on Y_2 . When we subtract that constant from f , we obtain a nonconstant rational function that is zero on Y_2 . But since Y has dimension 1, the zero locus of a rational function is finite. This is a contradiction. \square

8.4 The Birkhoff-Grothendieck Theorem

birkgroth

This theorem describes finite, torsion-free modules on the projective line. We'll denote \mathbb{P}^1 by X here.

8.4.1. Birkhoff-Grothendieck Theorem. *A finite, torsion-free \mathcal{O} -module on the projective line X is isomorphic to a direct sum of twisting modules: $\mathcal{M} \approx \bigoplus \mathcal{O}(n_i)$.*

BGtheorem

This theorem was proved by Grothendieck in 1957 using cohomology, but it had been proved by Birkhoff much earlier, in 1909, in the following equivalent form:

Birkhoff Factorization Theorem. Let $A_0 = \mathbb{C}[u]$, $A_1 = \mathbb{C}[u^{-1}]$, and $A_{01} = \mathbb{C}[u, u^{-1}]$. Let P be an invertible A_{01} -matrix. There exist an invertible A_0 -matrix Q_0 and an invertible A_1 -matrix Q_1 such that $Q^{-1}PQ_1$ is diagonal, and such that its diagonal entries are integer powers of u .

We recall the cohomology of the twisting modules on the projective line X : Let r be a positive integer. According to Theorem 7.5.4,

$$h^0\mathcal{O}(r) = r+1, \quad h^1\mathcal{O}(r) = 0, \quad h^0\mathcal{O}(-r) = 0, \quad \text{and} \quad h^1\mathcal{O}(-r) = r-1.$$

8.4.2. Lemma. *and let \mathcal{M} be a finite, torsion-free \mathcal{O} -module on the projective line X . For sufficiently large r ,*

mapstoMbounded

(i) *the only module homomorphism $\mathcal{O}(r) \rightarrow \mathcal{M}$ is the zero map, and*

(ii) $h^0(X, \mathcal{M}(-r)) = 0$.

proof. (i) A nonzero map from the invertible module $\mathcal{O}(r)$ to the locally free module \mathcal{M} will be injective (8.2.4), and the associated map $H^0(X, \mathcal{O}(r)) \rightarrow H^0(X, \mathcal{M})$ will also be injective. So $h^0(X, \mathcal{O}(r)) \leq h^0(X, \mathcal{M})$. Since $h^0(X, \mathcal{O}(r)) = r+1$ and since $h^0(X, \mathcal{M})$ is finite, r is bounded.

(ii) A global section of $\mathcal{M}(-r)$ defines a map $\mathcal{O} \rightarrow \mathcal{M}(-r)$. Its twist by r will be a map $\mathcal{O}(r) \rightarrow \mathcal{M}$. \square

proof of the Birkhoff-Grothendieck Theorem. This is Grothendieck's proof.

Lemma 8.1.1 tells us that \mathcal{M} is locally free. We use induction on the rank of \mathcal{M} . We suppose that \mathcal{M} has rank $r > 0$, and that the theorem has been proved for locally free \mathcal{O} -modules of rank less than r . The plan is to show that \mathcal{M} has a twisting module as a direct summand, so that $\mathcal{M} = \mathcal{W} \oplus \mathcal{O}(n)$ for some \mathcal{W} . Then induction on the rank can be applied to \mathcal{W} .

Since twisting is compatible with direct sums, we may replace \mathcal{M} by a twist $\mathcal{M}(n)$. Instead of showing that \mathcal{M} has a twisting module $\mathcal{O}(n)$ as a direct summand, we show that, after we replace \mathcal{M} by a suitable twist, the structure sheaf \mathcal{O} will be a direct summand.

As we know (6.7.21), the twist $\mathcal{M}(n)$ will have a nonzero global section when n is sufficiently large, and it will have no nonzero global section when n is sufficiently negative (Lemma 8.4.2 (ii)). Therefore, when we replace \mathcal{M} by a suitable twist, we will have $H^0(X, \mathcal{M}) \neq 0$ but $H^0(X, \mathcal{M}(-1)) = 0$. We assume that this is true for \mathcal{M} .

We choose a nonzero global section s of \mathcal{M} and consider the injective multiplication map $\mathcal{O} \xrightarrow{s} \mathcal{M}$. Let \mathcal{W} be its cokernel, so that we have a short exact sequence

$$(8.4.3) \quad 0 \rightarrow \mathcal{O} \xrightarrow{s} \mathcal{M} \rightarrow \mathcal{W} \rightarrow 0$$

cvcwsequence sectionbasic

8.4.4. Lemma. *Let \mathcal{W} be the \mathcal{O} -module that appears in the sequence (8.4.3).*

(i) $H^0(X, \mathcal{W}(-1)) = 0$.

(ii) \mathcal{W} is torsion-free, and therefore locally free.

(iii) \mathcal{W} is a direct sum $\bigoplus_{i=1}^{r-1} \mathcal{O}(n_i)$ of twisting modules on \mathbb{P}^1 , with $n_i \leq 0$.

proof. (i) This follows from the cohomology sequence associated to the twisted sequence

$$0 \rightarrow \mathcal{O}(-1) \rightarrow \mathcal{M}(-1) \rightarrow \mathcal{W}(-1) \rightarrow 0$$

because $H^0(X, \mathcal{M}(-1)) = 0$ and $H^1(X, \mathcal{O}(-1)) = 0$.

(ii) If \mathcal{W} had a nonzero torsion submodule, the torsion submodule of $\mathcal{W}(-1)$ would also be nonzero, and then $\mathcal{W}(-1)$ would have a nonzero global section (8.1.1).

(iii) The fact that \mathcal{W} is a direct sum of twisting modules follows by induction on the rank: $\mathcal{W} \approx \bigoplus \mathcal{O}(n_i)$. Since $H^0(X, \mathcal{W}(-1)) = 0$, we must have $H^0(X, \mathcal{O}(n_i - 1)) = 0$ too. Therefore $n_i - 1 < 0$, and $n_i \leq 0$. \square

We go back to the proof of Theorem 8.4.1. Lemma 8.1.20 tells us that the dual of the sequence (8.4.3) is an exact sequence

$$0 \rightarrow \mathcal{W}^* \rightarrow \mathcal{M}^* \rightarrow \mathcal{O}^* \rightarrow 0$$

and $\mathcal{W}^* \approx \bigoplus \mathcal{O}(-n_i)$ with $-n_i \geq 0$. Therefore $\mathbf{h}^1 \mathcal{W}^* = 0$. The map $H^0(\mathcal{M}) \rightarrow H^0(\mathcal{O}^*)$ is surjective. Lemma 8.1.20 tells us that \mathcal{M}^* is isomorphic to $\mathcal{W}^* \oplus \mathcal{O}^*$. Then \mathcal{M} is isomorphic to $\mathcal{W} \oplus \mathcal{O}$. \square

8.5 Differentials

diff

Why differentials enter into the Riemann-Roch Theorem is a mystery, but they do, so we introduce them here.

Let A be an algebra and let M be an A -module. A *derivation* $A \xrightarrow{\delta} M$ is a \mathbb{C} -linear map that satisfies the product rule for differentiation – a map that has these properties:

$$(8.5.1) \quad \delta(ab) = a \delta b + b \delta a, \quad \delta(a+b) = \delta a + \delta b, \quad \text{and} \quad \delta c = 0$$

for all a, b in A and all c in \mathbb{C} . The fact that δ is \mathbb{C} -linear, i.e., that it is a homomorphism of vector spaces, follows: Since $dc = 0$, $\delta(cb) = c \delta b$. For example, differentiation $\frac{d}{dt}$ is a derivation $\mathbb{C}[t] \rightarrow \mathbb{C}[t]$.

compde

8.5.2. Lemma. Let $A \xrightarrow{\varphi} B$ be an algebra homomorphism, and let $M \xrightarrow{f} N$ be a homomorphism of B -modules.

(i) Let $B \xrightarrow{\delta} M$ be a derivation. The composed maps $A \xrightarrow{\delta \circ \varphi} M$ and $B \xrightarrow{f \circ \delta} N$ are derivations.

(ii) Suppose that the homomorphism φ is surjective. Let $B \xrightarrow{g} M$ be a map, and let $d = g \circ \varphi$. If $A \xrightarrow{d} M$ is a derivation, then g is a derivation. \square

The *module of differentials* Ω_A of an algebra A is an A -module that is generated by elements denoted by da , one for each element a of A . Its elements are (finite) combinations $\sum b_i da_i$, with a_i and b_i in A . The defining relations among the generators da are the ones that make the map $A \xrightarrow{d} \Omega_A$ that sends a to da a derivation. For all a, b in A and all c in \mathbb{C} ,

$$(8.5.3) \quad d(ab) = a db + b da, \quad d(a+b) = da + db, \quad \text{and} \quad dc = 0$$

The elements of Ω_A are called *differentials*.

ho-

8.5.4. Lemma.

momderiv

(i) When we compose a homomorphism $\Omega_A \xrightarrow{\varphi} M$ of \mathcal{O} -modules with the derivation $A \xrightarrow{d} \Omega_A$, we obtain a derivation $A \xrightarrow{\varphi \circ d} M$. Composition with d defines a bijection between homomorphisms $\Omega_A \rightarrow M$ and derivations $A \xrightarrow{\delta} M$.

(ii) Ω is a functor: An algebra homomorphism $A \xrightarrow{u} B$ induces a homomorphism $\Omega_A \xrightarrow{v} \Omega_B$ that is compatible with the ring homomorphism u , and that makes a diagram

$$\begin{array}{ccc} B & \xrightarrow{d} & \Omega_B \\ u \uparrow & & \uparrow v \\ A & \xrightarrow{d} & \Omega_A \end{array}$$

By compatibility of v with u we mean that, if ω is an element of Ω_A and α is in A , then $v(\alpha\omega) = u(\alpha)v(\omega)$. *proof.* (i) The composition $\delta = \varphi \circ d$ is a derivation $A \rightarrow M$. In the other direction, given a derivation $A \xrightarrow{\delta} M$, we define a map $\Omega_A \xrightarrow{\varphi} M$ by $\varphi(da) = \delta(a)$. It follows from the defining relations for Ω_A that φ is a well-defined homomorphism of A -modules.

(ii) When Ω_B is made into an A -module by restriction of scalars, the composed map $A \xrightarrow{u} B \xrightarrow{d} \Omega_B$ will be a derivation to which (i) applies. \square

8.5.5. Lemma. *Let R be the polynomial ring $\mathbb{C}[x_1, \dots, x_n]$. The R -module of differentials Ω_R is a free module with basis dx_1, \dots, dx_n .* omegafree

proof. The formula $df = \sum \frac{df}{dx_i} dx_i$ follows from the defining relations. It shows that the elements dx_1, \dots, dx_n generate the R -module Ω_R . Let v_1, \dots, v_n be a basis of a free R -module V . The product rule for derivatives shows that the map $\delta : R \rightarrow V$ by $\delta(f) = \frac{\partial f}{\partial x_i} v_i$ is a derivation. It induces a module homomorphism $\Omega_A \rightarrow V$ that sends dx_i to v_i . Since dx_1, \dots, dx_n generate Ω_R and since v_1, \dots, v_n is a basis of V , φ is an isomorphism. \square

8.5.6. Proposition. *Let I be an ideal of an algebra R , let A be the quotient algebra R/I , and let dI denote the set of differentials df with f in I . The subset $N = dI + I\Omega_R$ is a submodule of Ω_R , and Ω_A is isomorphic to the quotient module Ω_R/N .* omegafreetwo

The proposition can be interpreted this way: Suppose that the ideal I is generated by elements f_1, \dots, f_r of R . Then Ω_A is the quotient of Ω_R that is obtained from Ω_R by introducing these two rules:

- $df_i = 0$, and
- multiplication by f_i is zero.

For example, let A be the quotient $\mathbb{C}[y]/(y^2)$ of a polynomial ring R in one variable. Here I is the principal ideal (y^2) , $2y dy$ generates dI , and $y^2 dy$ generates $I\Omega_A$. So $y dy$ generates the R -module N . Then, if \bar{y} denotes the residue of y in A , Ω_A is generated by an element $d\bar{y}$, with the relation $2\bar{y} d\bar{y} = 0$. In particular, it isn't the zero module.

proof of Proposition 8.5.6. First, $I\Omega_R$ is a submodule of Ω_R , and dI is an additive subgroup of Ω_R . To show that N is a submodule, we must show that scalar multiplication by an element of R maps dI to N , i.e., that if g is in R and f is in I , then $g df$ is in N . By the product rule, $g df = d(fg) - f dg$. Since I is an ideal, fg is in I . Then $d(fg)$ is in dI , and $f dg$ is in $I\Omega_R$. So $g df$ is in N .

The two rules shown above hold in Ω_A because the generators f_i of I are zero in A . Therefore N is in the kernel of the surjective map $\Omega_R \xrightarrow{v} \Omega_A$ defined by the homomorphism $R \rightarrow A$. Let $\bar{\Omega}$ denote the quotient module Ω_R/N . This is an A -module, and because $N \subset \ker v$, v defines a surjective map of A -modules $\bar{\Omega} \xrightarrow{\bar{v}} \Omega_A$. We show that \bar{v} is bijective. Let r be an element of R , let a be its image in A , and let \bar{dr} be its image in $\bar{\Omega}$. The composed map $R \xrightarrow{d} \Omega_R \xrightarrow{\pi} \bar{\Omega}$ is a derivation that sends r to \bar{dr} , and because I is in its kernel, it defines a derivation $R/I = A \xrightarrow{\delta} \bar{\Omega}$ that sends a to \bar{dr} . This derivation corresponds to a homomorphism of A -modules $\Omega_A \rightarrow \bar{\Omega}$ that sends da to \bar{dr} , and that inverts \bar{v} (8.5.4). \square

8.5.7. Corollary. *If A is a finite-type algebra, then Ω_A is a finite A -module.* Omegafinite

This follows from Proposition 8.5.6 because the module of differentials on the polynomial ring $\mathbb{C}[x_1, \dots, x_n]$ is a finite module. \square

8.5.8. Lemma. *Let S be a multiplicative system in a domain A , and let $S^{-1}\Omega_A$ be the module of fractions of Ω_A . The modules $S^{-1}\Omega_A$ and $\Omega_{S^{-1}A}$ are canonically isomorphic. In particular, if K is the field of fractions of A , then $K \otimes_A \Omega_A \approx \Omega_K$.* localizeomega

We have moved the symbol S^{-1} to the left for clarity.

proof of Lemma 8.5.8. The composition $A \rightarrow S^{-1}A \xrightarrow{d} \Omega_{S^{-1}A}$ is a derivation that defines an A -module homomorphism $\Omega_A \rightarrow \Omega_{S^{-1}A}$. This homomorphism extends to an $S^{-1}A$ -homomorphism $S^{-1}\Omega_A \xrightarrow{\varphi} \Omega_{S^{-1}A}$ because scalar multiplication by the elements of S is invertible in $\Omega_{S^{-1}A}$. The relation $ds^{-k} = -ks^{k-1}ds$ follows from the definition of a differential, and it shows that φ is surjective. The quotient rule

$$\delta(s^{-k}a) = -ks^{-k-1}a ds + s^{-k}da$$

can be used to define a derivation $S^{-1}A \xrightarrow{\delta} S^{-1}\Omega_A$, which corresponds to a homomorphism $\Omega_{S^{-1}A} \rightarrow S^{-1}\Omega_A$ that inverts φ . Here, one must show that δ is well-defined, that $\delta(s_1^{-k}a_1) = \delta(s_2^{-\ell}a_2)$ if $s_1^{-\ell}a_1 = s_2^{-k}a_2$, and that δ is a derivation. You will be able to do this. \square

Lemma 8.5.8 shows that a finite \mathcal{O} -module Ω_Y of differentials on a variety Y is defined. When $U = \text{Spec } A$ is an affine open subset of Y , $\Omega_Y(U) = \Omega_A$.

omega-funct **8.5.9. Proposition.** *The module Ω_Y of differentials on a smooth curve Y is invertible. If y is a local generator for the maximal ideal at a point q , then in a suitable neighborhood of q , Ω_Y is a free \mathcal{O} -module with basis dy .*

proof. We may assume that Y is affine, say $Y = \text{Spec } B$. Let q be a point of Y , and let y be an element of B with $v_q(y) = 1$. To show that dy generates Ω_B locally, we may localize, so we may suppose that y generates the maximal ideal \mathfrak{m} at q . We must show that after we localize B once more, every differential df with f in B will be a multiple of dy . Let $c = f(q)$. Then $f = c + yg$ for some g in B , and because $dc = 0$, $df = g dy + y dg$. Here $g dy$ is in $B dy$ and $y dg$ is in $\mathfrak{m}\Omega_B$, so

$$\Omega_B = B dy + \mathfrak{m}\Omega_B$$

Let W denote the quotient module $\Omega_B/(B dy)$. Then $W = \mathfrak{m}W$. The Nakayama Lemma tells us that there is an element z in \mathfrak{m} such that $s = 1 - z$ annihilates W . When we replace B by its localization B_s , we will have $W = 0$ and $\Omega_B = B dy$, as required.

We must still verify that dy isn't a torsion element. If it were, say $b dy = 0$, then because dy is a local generator, Ω_B would be the zero module except at the finite set of zeros of b . Since the chosen point q of Y was arbitrary, it suffices to show that the local generator dy for Ω_B isn't equal to zero. Let $R = \mathbb{C}[y]$ and $A = \mathbb{C}[y]/(y^2)$. The module Ω_R is free, with basis dy , and as noted above, if \bar{y} is the residue of y in A , the A -module Ω_A is generated by $d\bar{y}$, with the relation $2\bar{y} d\bar{y} = 0$. It isn't the zero module. Proposition 5.3.7 tells us that, at our point q , the algebra B/\mathfrak{m}_q^2 is isomorphic to A , and Proposition 8.5.6 tells us that Ω_A is a quotient of Ω_B . Since Ω_A isn't zero, neither is Ω_B . \square

8.6 Trace

tracediff
tracefn

(8.6.1) trace of a function

Let $Y \xrightarrow{\pi} X$ be a branched covering of smooth curves, and let F and K be the function fields of X and Y , respectively.

The trace map $K \xrightarrow{\text{tr}} F$ for a field extension of finite degree has been defined before (4.3.11). If α is an element of K , multiplication by α on the F -vector space K is an F -linear operator, and $\text{tr}(k)$ is the trace of that operator. The trace is F -linear: If f_i are in F and α_i are in K , then $\text{tr}(\sum f_i \alpha_i) = \sum f_i \text{tr}(\alpha_i)$. Moreover, the trace carries regular functions to regular functions: If $X' = \text{Spec } A'$ is an affine open subset of X , with inverse image $Y' = \text{Spec } B'$, then because A' is a normal algebra, the trace of an element of B' will be in A' (4.3.7). Using our abbreviated notation \mathcal{O}_Y for $\pi_* \mathcal{O}_Y$, the trace defines a homomorphism of \mathcal{O}_X -modules

$$(8.6.2) \quad \mathcal{O}_Y \xrightarrow{\text{tr}} \mathcal{O}_X$$

trace-global

Analytically, the trace can be described as a sum over the sheets of the covering. Let $n = [Y : X]$. Over a point p of X that isn't a branch point, there will be n points q_1, \dots, q_n of Y . If U is a small neighborhood of p in X in the classical topology, its inverse image V will consist of disjoint neighborhoods V_i of q_i , each of which maps bijectively to U . On V_i , the ring \mathcal{B} of analytic functions will be isomorphic to the ring \mathcal{A} of analytic functions on U . So \mathcal{B} is isomorphic to the direct sum $\mathcal{A}_1 \oplus \dots \oplus \mathcal{A}_n$ of n copies of \mathcal{A} . If a rational function g on Y is regular on V , its restriction to V can be written as $g = g_1 \oplus \dots \oplus g_n$, with g_i in \mathcal{A}_i . The matrix of left multiplication by g on $\mathcal{A}_1 \oplus \dots \oplus \mathcal{A}_n$ is the diagonal matrix with entries g_i , so

$$(8.6.3) \quad \text{tr}(g) = g_1 + \dots + g_n$$

trsum

tracesum **8.6.4. Lemma.** *Let $Y \xrightarrow{\pi} X$ be a branched covering of smooth curves, let p be a point of X , let q_1, \dots, q_k be the fibre over p , and let e_i be the ramification index at q_i . If a rational function g on Y is regular at the points q_1, \dots, q_k , its trace is regular at p , and its value at p is $[\text{tr}(g)](p) = e_1 g(q_1) + \dots + e_k g(q_k)$.*

proof. The regularity was discussed above. If p isn't a branch point, we will have $k = n$ and $e_i = 1$ for all i . In this case, the lemma follows by evaluating (8.6.3). It follows by continuity for any point p . As a point p' approaches p , e_i points q' of Y approach q_i (8.1.8). For each such point, the limit of $g(q')$ will be $g(q_i)$. \square

(8.6.5) trace of a differential

traced

The structure sheaf is naturally contravariant. A branched covering $Y \xrightarrow{\pi} X$ corresponds to an \mathcal{O}_X -module homomorphism $\mathcal{O}_X \rightarrow \mathcal{O}_Y$. The trace map for functions is a homomorphism of \mathcal{O}_X -modules in the opposite direction: $\mathcal{O}_Y \xrightarrow{\text{tr}} \mathcal{O}_X$.

Differentials are also naturally contravariant. A morphism $Y \rightarrow X$ induces an \mathcal{O}_X -module homomorphism $\Omega_X \rightarrow \Omega_Y$ that sends a differential dx on X to a differential on Y that we denote by dx too (8.5.4) (ii). As is true for functions, there is a trace map for differentials in the opposite direction. It is defined below, in (8.6.7), and will be denoted by τ :

$$\Omega_Y \xrightarrow{\tau} \Omega_X$$

First, a lemma about the natural contravariant map $\Omega_X \rightarrow \Omega_Y$:

8.6.6. Lemma. (i) *Let p be the image in X of a point q of Y , let x and y be local generators for the maximal ideals of X and Y at p and q , respectively, and let e be the ramification index at q . Then $dx = vy^{e-1}dy$, where v is a local unit at q .*

dx dy

(ii) *The canonical homomorphism $\Omega_X \rightarrow \Omega_Y$ is injective.*

proof. (i) As we have noted before, $x = uy^e$, where u is a local unit. Since dy generates Ω_Y locally, there is a rational function z that is regular at q , such that $du = zdy$. Then $dx = d(uy^e) = y^e z dy + ey^{e-1}u dy = vy^{e-1}dy$, where $v = yz + eu$. Since yz is zero at q and eu is a local unit there, v is a local unit.

(ii) See (8.2.4). □

To define the trace for differentials, we begin with differentials of the functions fields. Let F and K be the function fields of X and Y , respectively. Because the \mathcal{O}_Y -module Ω_Y is invertible, the module Ω_K of K -differentials, which is the localization $\Omega_Y \otimes_{\mathcal{O}_Y} K$, is a free K -module of rank one. Any nonzero differential will form a K -basis. We choose as basis a nonzero F -differential α . Its image in Ω_K , which we denote by α too, will be a K -basis for Ω_K . We can, for example, take $\alpha = dx$, where x is a local coordinate function on X .

Since α is a basis, an element β of Ω_K can be written uniquely, as

$$\beta = g\alpha$$

where g is an element of K . The trace $\Omega_K \xrightarrow{\tau} \Omega_F$ is defined by

$$(8.6.7) \quad \tau(\beta) = \text{tr}(g)\alpha$$

deftrdif

where $\text{tr}(g)$ is the trace of the function g . Since the trace for functions is F -linear, τ is also an F -linear map.

We need to check that τ is independent of the choice of α . If α' is another nonzero F -differential, then $f\alpha' = \alpha$ for some nonzero element f of F , and $g\alpha = gf\alpha'$. Since tr is F -linear and $f \in F$, $\text{tr}(gf) = f \text{tr} g$, and

$$\text{tr}(gf)\alpha' = \text{tr}(g)f\alpha' = \text{tr}(g)\alpha$$

Using α' in place of α gives the same value for the trace.

A differential of the function field K will be called a *rational differential*. A rational differential β is *regular* at a point q of Y if there is an affine open neighborhood $Y' = \text{Spec } B$ of q such that β is an element of Ω_B . If y is a local generator for the maximal ideal \mathfrak{m}_q and $\beta = g dy$, the differential β is regular at q if the rational function g is regular there.

Let p be a point of X . Working locally at p , we may suppose that X and Y are affine, $X = \text{Spec } A$ and $Y = \text{Spec } B$, that the maximal ideal at p is a principal ideal, generated by an element x of A , and that the differential dx generates Ω_A . Let q_1, \dots, q_k be the points of Y that lie over p , and let e_i be the ramification index at q_i .

poleorder

8.6.8. Corollary. *With notation as above,*

(i) *When viewed as a differential on Y , dx has a zero of order $e_i - 1$ at q_i .*

(ii) *If a differential β on Y is regular at the points q_1, \dots, q_k , then $\beta = g dx$, where g is a rational function with a pole of order at most $e_i - 1$ at q_i .*

This follows from Lemma 8.6.6 (i). □

tracereg

8.6.9. Main Lemma. *Let $Y \xrightarrow{\pi} X$ be a branched covering, let p be a point of X , and let q_1, \dots, q_k be the points of Y that lie over p . Also, let β be a rational differential on Y .*

(i) *If β is regular at the points q_1, \dots, q_k , its trace $\tau(\beta)$ is regular at p .*

(ii) *If β has a simple pole at q_i and is regular at q_j for all $j \neq i$, then $\tau(\beta)$ is not regular at p .*

proof. (i) Corollary 8.6.8 tells us that $\beta = g dx$, where g has poles of orders at most $e_i - 1$ at the points q_i . Since x has a zero of order e_i at q_i , the function xg is regular at q_i , and its value there is zero. Then $\text{tr}(xg)$ is regular at p , and its value at p is zero (8.6.4). So $x^{-1} \text{tr}(xg)$ is a regular function at p . Since tr is F -linear and x is in F , $x^{-1} \text{tr}(xg) = \text{tr}(g)$. Therefore $\text{tr}(g)$ and $\tau(\beta) = \text{tr}(g)dx$ are regular at p .

(ii) With $\beta = g dx$, the function xg will be regular at p . Its value at q_j will be zero when $j \neq i$, and not zero when $j = i$. Then $\text{tr}(xg)$ will be regular at p , but not zero there (8.6.4). Therefore $\tau(\beta) = x^{-1} \text{tr}(xg)dx$ won't be regular at p . □

8.6.10. Corollary. *The trace map defines a homomorphism of \mathcal{O}_X -modules $\Omega_Y \xrightarrow{\tau} \Omega_X$.* □

omegaYandX
sumroot-
cover

8.6.11. Example. Let Y be the locus $y^e = x$ in $\mathbb{A}_{x,y}^2$. Multiplication by $\zeta = e^{2\pi i/e}$ permutes the sheets of Y over X . The trace of a power y^k is

sumzeta

$$(8.6.12) \quad \text{tr}(y^k) = \sum_j \zeta^{jk} y^k$$

The sum $\sum \zeta^{kj}$ is zero unless $k \equiv 0$ modulo e . Then $dy = y^{1-e} dx/e$, and $\tau(dy) = \text{tr}(y^{1-e}) dx/e = 0$. But $y^{-1} dy = y^{-e} dx/e = x^{-1} dx/e$, and $\tau(y^{-1} dy) = \text{tr}(x^{-1}) dx/e = x^{-1} \text{tr}(1) dx/e = dx/x$. So dy/y isn't regular at $x = 0$. □

Let Y be a smooth curve, and let $Y \xrightarrow{\pi} X$ be a branched covering. As is true for any \mathcal{O}_Y -module, the module of differentials Ω_Y is isomorphic to the module of homomorphisms ${}_{\mathcal{O}_Y}(\mathcal{O}_Y, \Omega_Y)$. The homomorphism $\mathcal{O}_Y \rightarrow \Omega_Y$ that corresponds to a section β of Ω_Y on an open set U sends a regular function f on U to $f\beta$. We will denote that homomorphism by β too: $\mathcal{O}_Y \xrightarrow{\beta} \Omega_Y$.

compwtau

8.6.13. Lemma. *Composition with the trace defines a homomorphism of \mathcal{O}_X -modules*

$$\Omega_Y \approx_{\mathcal{O}_Y} ({}_{\mathcal{O}_Y}(\mathcal{O}_Y, \Omega_Y)) \xrightarrow{\tau} {}_{\mathcal{O}_X}(\mathcal{O}_Y, \Omega_X)$$

This is true because τ is \mathcal{O}_X -linear. An \mathcal{O}_Y -linear map becomes an \mathcal{O}_X -linear map by restriction of scalars. So when we compose an \mathcal{O}_Y -linear map β with τ , the result will be \mathcal{O}_X -linear. It is a homomorphism of \mathcal{O}_X -modules. □

8.6.14. Theorem. (i) *The map (8.6.13) is bijective.*

traceomega

(ii) *More generally, if \mathcal{M} is any locally free \mathcal{O}_Y -module, composition with the trace defines a bijection*

compw-
trace

$$(8.6.15) \quad {}_{\mathcal{O}_Y}(\mathcal{M}, \Omega_{\mathcal{O}_Y}) \xrightarrow{\tau \circ} {}_{\mathcal{O}_X}(\mathcal{M}, \Omega_{\mathcal{O}_X})$$

As we will see below, this theorem follows from the Main Lemma 8.6.9, when one looks closely.

Remark. The domain and range of the map (8.6.15) are to be interpreted as modules on X . For example, \mathcal{O}_Y denotes the direct image on X of the structure sheaf on Y . When we insert the symbols $\underline{\text{Hom}}$ and π_* into the notation, (8.6.15) becomes a bijection

$$\pi_* (\underline{\text{Hom}}_{\mathcal{O}_Y}(\mathcal{M}, \Omega_Y)) \xrightarrow{\tau \circ} \underline{\text{Hom}}_{\mathcal{O}_X}(\pi_* \mathcal{M}, \Omega_X)$$

Because the theorem is about modules on X , we can verify it locally on X . In particular, we may suppose that X and Y are affine, $X = \text{Spec } A$ and $Y = \text{Spec } B$. When we state the theorem in terms of algebras and modules, the statement of the theorem for the affine varieties becomes this:

8.6.16. Theorem. Let $Y \rightarrow X$ be a branched covering, with $Y = \text{Spec } B$ and $X = \text{Spec } A$.

(i) The trace map $\Omega_B = {}_B(B, \Omega_B) \xrightarrow{\tau \circ} {}_A(B, \Omega_A)$ is bijective.

(ii) For any locally free B -module M , composition with the trace defines a bijection ${}_B(M, \Omega_B) \xrightarrow{\tau \circ} {}_A(M, \Omega_A)$.

traceomegaalgebra

8.6.17. Lemma. Let $A \subset B$ be rings, let M be a B -module, and let N be an A -module. Then ${}_A(M, N)$ has the structure of a B -module.

homisB-mod

In the theorem, when we write ${}_A(M, \Omega_B)$, we are interpreting the B -modules Ω_B as an A -module by restriction of scalars, and N is also interpreted that way in ${}_A(M, N)$.

proof of the lemma We must define scalar multiplication of a homomorphism $M \xrightarrow{\varphi} N$ of A -modules by an element b of B . The definition of $b\varphi$ is $[b\varphi](m) = \varphi(bm)$. Here one must show that this map $[b\varphi]$ is a homomorphism of A -modules $M \rightarrow N$, and that the axioms for a B -module are true for ${}_A(M, N)$. You will be able to check these things. \square

proof of Theorem 8.6.14 (i). We use the algebra notation of Theorem 8.6.16. Since the theorem is local, we are still allowed to localize A . As A -modules, both B and Ω_B are torsion-free, and therefore locally free. Localizing as needed, we may assume that they are free A -modules, and that Ω_A is a free module of rank one with basis dx . Then ${}_A(B, \Omega_A)$ will be a free A -module too.

Let's denote ${}_A(B, \Omega_A)$ by Θ . Lemma 8.6.17 tells us that Θ is a B -module. Because B and Ω_A are locally free A -modules, Θ is a locally free A -module and a locally free B -module. Since Ω_A has A -rank 1, the A -rank of Θ is the same as the A -rank of B . So the B -rank of Θ is 1 (8.1.10)(ii). Therefore Θ is an invertible B -module.

The trace map $\Omega_B \xrightarrow{\tau} \Theta$ isn't the zero map because, if x is a local coordinate on X , then $\tau dx \neq 0$. Since domain and range are invertible B -modules, τ is an injective homomorphism. Its image, which is isomorphic to Ω_B , is an invertible submodule of the invertible B -module Θ . Therefore Θ is isomorphic to an invertible module $\Omega_B(D)$ for some effective divisor D (8.2.7). To complete the proof of the theorem, we show that the divisor D is zero.

Suppose that $D > 0$, let q be a point in the support of D . Then $\Omega_B(q) \subset \Omega_B(D) \approx \Theta$. Let p be the image of q in X . We choose a rational differential β in Ω_K that has a simple pole at q , and is regular at the other points of Y in the fibre over p . The Chinese Remainder Theorem allows us to do this. According to Proposition 8.2.11, the trace $\tau(\beta)$ isn't regular at p . It isn't in Θ . \square

proof of Theorem 8.6.14 (ii). We go back to the statement in terms of \mathcal{O} -modules. We are to show that if \mathcal{M} is a locally free \mathcal{O}_Y -module, composition with the trace defines a bijective map ${}_{\mathcal{O}_Y}(\mathcal{M}, \Omega_{\mathcal{O}_Y}) \rightarrow {}_{\mathcal{O}_X}(\mathcal{M}, \Omega_{\mathcal{O}_X})$. Part (i) of the theorem tells us that this is true in when $\mathcal{M} = \mathcal{O}_Y$, and therefore it is also true when \mathcal{M} is a free module \mathcal{O}_Y^k . And, since (ii) is a statement about \mathcal{O}_X -modules, it suffices to prove it locally on X . So it suffices to prove that a locally free \mathcal{O}_Y -module is free on the inverse image of an open set in X .

8.6.18. Lemma. Let q_1, \dots, q_k be points of a smooth curve Y , and let \mathcal{M} be a locally free \mathcal{O}_Y -module. There is an open set V that contains the points q_1, \dots, q_k , such that \mathcal{M} is free on V .

locallyfreeonX

We assume the lemma and complete the proof of the theorem. Let $\{q_1, \dots, q_k\}$ be the fibre over a point p of X and let V be as in the lemma. The complement $D = Y - V$ is a finite set whose image C in X is a finite set that doesn't contain p . If U is the complement of C in X , its inverse image W will be a subset of V that contains the fibre and on which \mathcal{M} is free. \square

proof of the lemma We may assume that Y is affine, $Y = \text{Spec } B$, and that the \mathcal{O} -module \mathcal{M} corresponds to a locally free B -module M .

We go back to Lemma 8.1.3. Let \mathfrak{m}_i be the maximal ideal of B at q_i , and let $\overline{B}_i = B/\mathfrak{m}_i^{e_i}$. The quotient $\overline{B} = B/xB$ is isomorphic to the product $\overline{B}_1 \times \dots \times \overline{B}_k$. Since \mathcal{M} is locally free, it is free in a neighborhood of each point q_i . Therefore $\overline{M}_i = M/\mathfrak{m}_i M$ is a free \overline{B}_i -module. whose dimension is the rank r of \mathcal{M} .

Let r be the rank of M . It follows from the Chinese Remainder Theorem that there are elements m_1, \dots, m_r in M whose residues form a basis of \overline{M}_i for every i . Let V be the free B -module with basis v_1, \dots, v_r , and let $V \xrightarrow{\varphi} M$ be the map defined by $\varphi(v_i) = m_i$, let C be the cokernel of φ , and let $\overline{V}_i = V/\mathfrak{m}_i V$. The map φ induces a bijection $\overline{V}_i \rightarrow \overline{M}_i$, and therefore $\overline{C}_i = C/\mathfrak{m}_i C$ is the zero module: $C = \mathfrak{m}_i C$. The Nakayama Lemma tells us that C is zero at q_i . Since C is a finite B -module, it is supported on a finite set F . When

we localize to delete this finite set from X , the elements m_1, \dots, m_k generate M , and since M has rank r , they form a basis. Then M is free. \square

Note. Theorem 8.6.14 is subtle, and I don't like the proof. It is understandable, but explain intuitively why Ω_B is isomorphic to ${}_A(B, \Omega_A)$. To get insight into that, we would need a better understanding of differentials. My father Emil Artin said: "One doesn't really understand differentials, but one can learn to work with them."

8.7 The Riemann-Roch Theorem II

roch
serredual

(8.7.1) the Serre dual

Let Y be a smooth projective curve, and let \mathcal{M} be a locally free \mathcal{O}_Y -module. The *Serre dual* of \mathcal{M} , which we will denote by $\mathcal{M}^\#$, is the module

defSerred-
ual

$$(8.7.2) \quad \mathcal{M}^\# = {}_Y(\mathcal{M}, \Omega_Y) \quad (= \underline{\text{Hom}}_{\mathcal{O}_Y}(\mathcal{M}, \Omega_Y))$$

Since the invertible module Ω_Y is locally isomorphic to \mathcal{O}_Y , the Serre dual $\mathcal{M}^\#$ will be locally isomorphic to the ordinary dual \mathcal{M}^* . It will be a locally free module with the same rank as \mathcal{M} , and the bidual $(\mathcal{M}^\#)^\#$ will be isomorphic to \mathcal{M} . This follows from Corollary 8.1.19, because $\mathcal{M}^\# \approx \mathcal{M}^* \otimes_{\mathcal{O}} \Omega_Y$. To spell this out,

$$(\mathcal{M}^\#)^\# \approx (\mathcal{M}^* \otimes_{\mathcal{O}} \Omega_Y)^* \otimes_{\mathcal{O}} \Omega_Y \approx \mathcal{M}^{**} \otimes_{\mathcal{O}} \Omega_Y^* \otimes_{\mathcal{O}} \Omega_Y \approx \mathcal{M}^{**} \approx \mathcal{M}$$

For example, $\mathcal{O}_Y^\# = \Omega_Y$ and $\Omega_Y^\# = \mathcal{O}_Y$.

dualco-
hom

8.7.3. Riemann-Roch Theorem, version 2. *Let \mathcal{M} be a locally free \mathcal{O}_Y -module on a smooth projective curve Y , and let $\mathcal{M}^\#$ be its Serre dual. Then $\mathbf{h}^0 \mathcal{M} = \mathbf{h}^1 \mathcal{M}^\#$ and $\mathbf{h}^1 \mathcal{M} = \mathbf{h}^0 \mathcal{M}^\#$.*

Because \mathcal{M} and $(\mathcal{M}^\#)^\#$ are isomorphic, the second assertion follows from the first one when one replaces \mathcal{M} by $\mathcal{M}^\#$. The two assertions are equivalent.

For example, $\mathbf{h}^1 \Omega_Y = \mathbf{h}^0 \mathcal{O}_Y = 1$ and $\mathbf{h}^0 \Omega_Y = \mathbf{h}^1 \mathcal{O}_Y = p_a$. If \mathcal{M} is a locally free \mathcal{O}_Y -module, then

chitwo

$$(8.7.4) \quad \chi(\mathcal{M}) = \mathbf{h}^0 \mathcal{M} - \mathbf{h}^0 \mathcal{M}^\#$$

A more precise statement of the Riemann-Roch Theorem is that $H^1(Y, \mathcal{M})$ and $H^0(Y, \mathcal{M}^\#)$ are dual vector spaces in a canonical way. We omit the proof of this. The fact that their dimensions are equal is enough for many applications. The canonical isomorphism becomes important when one wants to apply the theorem to a cohomology sequence.

Our plan is to prove Theorem 8.7.3 directly for the projective line. The structure of locally free modules on \mathbb{P}^1 is very simple, so this will be easy. Following Grothendieck, we derive it for an arbitrary smooth projective curve Y by projection to \mathbb{P}^1 .

Let Y be a smooth projective curve, let $X = \mathbb{P}^1$, and let $Y \xrightarrow{\pi} X$ be a branched covering. Let \mathcal{M} be a locally free \mathcal{O}_Y -module, and let the Serre dual of \mathcal{M} , as defined in (8.7.2), be

$$\mathcal{M}_1^\# = {}_Y(\mathcal{M}, \Omega_Y)$$

The direct image of \mathcal{M} is a locally free \mathcal{O}_X -module that we are denoting by \mathcal{M} too, and we can form the Serre dual on X . Let

$$\mathcal{M}_2^\# = {}_X(\mathcal{M}, \Omega_X)$$

about hom

8.7.5. Corollary. *The direct image $\pi_* \mathcal{M}_1^\#$, which we denote by $\mathcal{M}_1^\#$, is isomorphic to $\mathcal{M}_2^\#$.*

proof. This is Theorem 8.6.14. □

The corollary allows us to drop the subscripts from $\mathcal{M}^\#$. Because a branched covering $Y \xrightarrow{\pi} X$ is an affine morphism, the cohomology of \mathcal{M} and of its Serre dual $\mathcal{M}^\#$ can be computed, either on Y or on X . If \mathcal{M} is a locally free \mathcal{O}_Y -module, then $H^q(Y, \mathcal{M}) \approx H^q(X, \mathcal{M})$ and $H^q(Y, \mathcal{M}^\#) \approx H^q(X, \mathcal{M}^\#)$ (see (7.4.25)).

Thus it is enough to prove Riemann-Roch for the projective line.

(8.7.6) Riemann-Roch for the projective line

dualityfor
pone

The Riemann-Roch Theorem for the projective line $X = \mathbb{P}^1$ is a consequence of the Birkhoff-Grothendieck Theorem tells us that a locally free \mathcal{O}_X -module \mathcal{M} on X is a direct sum of twisting modules. To prove Riemann-Roch for the projective line, it suffices to prove it for the twisting modules $\mathcal{O}_X(k)$

8.7.7. Lemma. *The module of differentials Ω_X on X is isomorphic to the twisting module $\mathcal{O}_X(-2)$.*

omegapone

proof. Since Ω_X is invertible, the Birkhoff-Grothendieck Theorem tells us that it is isomorphic to a twisting module $\mathcal{O}_X(k)$ for some k . We need only identify the integer k .

Let $\mathbb{U}^0 = \text{Spec } \mathbb{C}[x]$, and $\mathbb{U}^1 = \text{Spec } \mathbb{C}[z]$ be the standard open subsets of \mathbb{P}^1 , with $z = x^{-1}$. On \mathbb{U}^0 , the module of differentials is free, with basis dx , and $dx = d(z^{-1}) = -z^{-2}dz$ describes the differential dx on \mathbb{U}^1 . Since the point p at infinity is $\{z = 0\}$, dx has a pole of order 2 there. It is a global section of $\Omega_X(2p)$, and as a section of that module, it isn't zero anywhere. So multiplication by dx defines an isomorphism $\mathcal{O} \rightarrow \Omega_X(2p)$ that sends 1 to dx . Tensoring with $\mathcal{O}(-2p)$, we find that Ω_X is isomorphic to $\mathcal{O}(-2p)$. □

8.7.8. Lemma. *Let \mathcal{M} and \mathcal{N} be locally free \mathcal{O} -modules on the projective line X . Then $\chi(\mathcal{M}(r), \mathcal{N})$ is canonically isomorphic to $\chi(\mathcal{M}, \mathcal{N}(-r))$.*

twisthom

proof. When we tensor a homomorphism $\mathcal{M}(r) \xrightarrow{\varphi} \mathcal{N}$ with $\mathcal{O}(-r)$, we obtain a homomorphism $\mathcal{M} \rightarrow \mathcal{N}(-r)$. Tensoring with $\mathcal{O}(r)$ is the inverse operation. □

The Serre dual $\mathcal{O}(n)^\#$ of $\mathcal{O}(n)$ is therefore

$$\mathcal{O}(n)^\# = \chi(\mathcal{O}(n), \mathcal{O}(-2)) \approx \mathcal{O}(-2-n)$$

To prove Riemann-Roch for $X = \mathbb{P}^1$, we must show that

$$\mathbf{h}^0\mathcal{O}(n) = \mathbf{h}^1X, \mathcal{O}(-2-n) \quad \text{and} \quad \mathbf{h}^1\mathcal{O}(n) = \mathbf{h}^0\mathcal{O}(-2-n)$$

This follows from Theorem 7.5.4, which computes the cohomology of the twisting modules. As we've noted before, these two assertions are equivalent, so it suffices to verify the first one. If $n < 0$, then $-2-n > 0$. In this case $\mathbf{h}^0\mathcal{O}(n) = \mathbf{h}^1\mathcal{O}(-2-n) = 0$. If $n \geq 0$, Theorem 7.5.4 asserts that $\mathbf{h}^0\mathcal{O}(n) = n+1$ and that $\mathbf{h}^1\mathcal{O}(-2-n) = (2+n) - 1 = n+1$.

8.8 Using Riemann-Roch

(8.8.1) genus

appl
genusm-
curve

There are three closely related numbers associated to a smooth projective curve Y : its *topological genus* g , its *arithmetic genus* $p_a = \mathbf{h}^1\mathcal{O}_Y$, and the *degree* δ of the module of differentials Ω_Y (see 8.2).

8.8.2. Theorem. *Let Y be a smooth projective curve. The topological genus g and the arithmetic genus p_a of Y are equal, and the degree δ of the module Ω_Y is $2p_a - 2$, which is equal to $2g - 2$.*

genus-
genus

Thus the Riemann-Roch Theorem 8.3.3 can we written as

$$\chi(\mathcal{O}(D)) = \deg D + 1 - g$$

We'll write it this way in what follows.

proof. Let $Y \xrightarrow{\pi} X$ be a branched covering with $X = \mathbb{P}^1$. The topological Euler characteristic $e(Y)$, which is $2 - 2g$, can be computed in terms of the branching data for the covering, as in (1.8.23). Let q_i be the ramification points in Y , and let e_i be the ramification index at q_i . Then e_i sheets of the covering come together at q_i . One might say that, in Y , $e_i - 1$ points are lacking. If the degree of Y over X is n , then since $e(X) = 2$,

$$\text{degdelta} \quad (8.8.3) \quad 2 - 2g = e(Y) = ne(X) - \sum (e_i - 1) = 2n - \sum (e_i - 1)$$

We compute the degree δ of Ω_Y in two ways. First, the Riemann-Roch Theorem tells us that $\mathbf{h}^0\Omega_Y = \mathbf{h}^1\mathcal{O}_Y = p_a$ and $\mathbf{h}^1\Omega_Y = \mathbf{h}^0\mathcal{O}_Y = 1$. So $\chi(\Omega_Y) = -\chi(\mathcal{O}_Y) = p_a - 1$. The Riemann-Roch Theorem also tells us that $\chi(\Omega_Y) = \delta + 1 - p_a$ (8.3.8). Therefore

$$\text{delta} \quad (8.8.4) \quad \delta = 2p_a - 2$$

Next, we compute δ by computing the divisor of the differential dx on Y , x being a coordinate in X . Let q_i be one of the ramification points in Y , and let e_i be the ramification index at q_i . Then dx has a zero of order $e_i - 1$ at q_i . On X , dx has a pole of order 2 at ∞ . Let's suppose that the point at infinity isn't a branch point. Then there will be n points of Y at which dx has a pole of order 2, n being the degree of Y over X , as above. The degree of Ω_Y is therefore

$$\text{deltatwo} \quad (8.8.5) \quad \delta = \text{zeros} - \text{poles} = \sum (e_i - 1) - 2n$$

Combining (8.8.5) with (8.8.3), one sees that $\delta = 2g - 2$. Since we also have $\delta = 2p_a - 2$, we conclude that $g = p_a$. \square

Honezero **8.8.6. Corollary.** *Let D be a divisor on a smooth projective curve Y of genus g . If $\deg D > 2g - 2$, then $\mathbf{h}^1\mathcal{O}(D) = 0$. If $\deg D \leq g - 2$, then $\mathbf{h}^1\mathcal{O}(D) > 0$.*

proof. This follows from Corollary 8.3.10 (v). \square

genuszero (8.8.7) curves of genus zero

Let Y be a smooth projective curve Y whose genus g is zero, and let p be a point of Y . The exact sequence

$$0 \rightarrow \mathcal{O}_Y \rightarrow \mathcal{O}_Y(p) \rightarrow \epsilon \rightarrow 0$$

where ϵ is a one-dimensional module supported at p , gives us an exact cohomology sequence

$$0 \rightarrow H^0(Y, \mathcal{O}_Y) \rightarrow H^0(Y, \mathcal{O}_Y(p)) \rightarrow H^0(Y, \epsilon) \rightarrow 0$$

The zero on the right is due to the fact that $\mathbf{h}^1\mathcal{O}_Y = g = 0$. We also have $\mathbf{h}^0\mathcal{O}_Y = 1$ and $\mathbf{h}^0\epsilon = 1$, so $\mathbf{h}^0\mathcal{O}_Y(p) = 2$. We choose a basis $(1, x)$ for $H^0(Y, \mathcal{O}_Y(p))$, 1 being the constant function and x being a nonconstant function with a single pole of order 1 at p . This basis defines a point of \mathbb{P}^1 with values in the function field K of Y , and therefore a morphism $Y \xrightarrow{\varphi} \mathbb{P}^1$. Because x has just one pole of order 1, it takes every value exactly once. Therefore φ is bijective. It is a map of degree 1, and therefore an isomorphism (8.1.5).

gzero **8.8.8. Corollary.** *Every smooth projective curve of genus zero is isomorphic to the projective line \mathbb{P}^1 .* \square

A curve, smooth or not, whose function field is isomorphic to the field $\mathbb{C}(t)$ of rational functions in one variable is called a *rational curve*. A smooth projective curve of genus zero is a rational curve.

genusone (8.8.9) curves of genus one

A smooth projective curve of genus $g = 1$ is called an *elliptic curve*. The Riemann-Roch Theorem tells us that on an elliptic curve Y ,

$$\chi(\mathcal{O}(D)) = \deg D$$

Since $\mathbf{h}^0\Omega_Y = \mathbf{h}^1\mathcal{O}_Y = 1$, Ω_Y has a nonzero global section ω . Since Ω_Y has degree zero (8.8.2), ω doesn't vanish anywhere. Multiplication by ω defines an isomorphism $\mathcal{O} \rightarrow \Omega_Y$. So Ω_Y is a free module of rank one.

The next lemma follows from Riemann-Roch.

8.8.10. Lemma. (i) *If D is a divisor of degree one on a smooth projective curve of positive genus, then $\mathbf{h}^0\mathcal{O}(p) \leq 1$.*

*hrpforel-
liptic*

Let p be a point of an elliptic curve Y . For any $r > 0$, $\mathbf{h}^0\mathcal{O}(rp) = r$, and $\mathbf{h}^1\mathcal{O}(rp) = 0$. □

Since $H^0(Y, \mathcal{O}_Y) \subset H^0(Y, \mathcal{O}_Y(p))$, and since both spaces have dimension one, they are equal. So (1) is a basis for $H^0(Y, \mathcal{O}_Y(p))$. We choose a basis $(1, x)$ for the two-dimensional space $H^1(Y, \mathcal{O}_Y(2p))$. Then x isn't a section of $\mathcal{O}(p)$. It has a pole of order precisely 2 at p and no other pole. Next, we choose a basis $(1, x, y)$ for $H^1(Y, \mathcal{O}_Y(3p))$. So y has a pole of order 3 at p , and no other pole. The point $(1, x, y)$ of \mathbb{P}^2 with values in K determines a morphism $Y \xrightarrow{\varphi} \mathbb{P}^2$.

Let u, v, w be coordinates in \mathbb{P}^2 . The map φ sends a point q distinct from p to $(u, v, w) = (1, x(q), y(q))$. Since Y has dimension one, φ is a finite morphism. Its image Y' will be a closed subvariety of \mathbb{P}^2 of dimension one – a plane curve.

To determine the image of the point p , we multiply $(1, x, y)$ by $\lambda = y^{-1}$, obtaining the equivalent vector $(y^{-1}, xy^{-1}, 1)$. The rational function y^{-1} has a zero of order 3 at p , and xy^{-1} has a simple zero there. Evaluating at p , we see that the image of p is the point $(0, 0, 1)$.

The map $Y \rightarrow \mathbb{P}^2$ restricts to a finite morphism $Y \rightarrow Y'$, where Y' is the image. Let ℓ be a generic line $\{au + bv + cw = 0\}$ in \mathbb{P}^2 . The rational function $a + bx + cy$ on Y has a pole of order 3 at p and no other pole. It takes every value, including zero, three times, and the set of three points of Y at which $a + bx + cy$ is zero is the inverse image of the intersection $Y' \cap \ell$. The only possibilities for the degree of Y' are 1 and 3. Since $1, x, y$ are independent, they don't satisfy any homogeneous linear equation. So Y' isn't a line. The image Y' is a cubic curve (see Corollary 1.3.9).

To determine the image, we look for a cubic relation among the functions $1, x, y$ on Y . The seven monomials $1, x, y, x^2, xy, x^3, y^2$ have poles at p of orders $0, 2, 3, 4, 5, 6, 6$, respectively, and no other poles. They are sections of $\mathcal{O}_Y(6p)$. Riemann-Roch tells us that $\mathbf{h}^0\mathcal{O}_Y(6p) = 6$. So those seven functions are linearly dependent. The dependency relation gives us a cubic equation among x and y , which we may write in the form

$$cy^2 + (a_1x + a_3)y + (a_0x^3 + a_2x^2 + a_4x + a_6) = 0$$

There can be no linear relation among functions whose orders of pole at p are distinct. So, when we delete either x^3 or y^2 from the list of monomials, we obtain an independent set of six functions. They form a basis for the six-dimensional space $H^0(Y, \mathcal{O}(6p))$. So, in the cubic relation, the coefficients c and a_0 aren't zero. We normalize c and a_0 to 1. We eliminate the linear term in y from the relation by substituting $y - \frac{1}{2}(a_1x + a_3)$ for y . Next, we eliminate the quadratic term in x by substituting $x - \frac{1}{3}a_2$ for x . Bringing the terms in x to the other side of the equation, we are left with a cubic relation of the form

$$y^2 = x^3 + a_4x + a_6$$

The coefficients a_4 and a_6 have changed, of course.

The cubic curve Y' defined by the homogenized equation $y^2z = x^3 + a_4xz^2 + a_6z^3$ is the image of Y . This curve meets a generic line $ax + by + cz = 0$ in three points and, as we saw above, its inverse image in Y consists of three points too. Therefore the morphism $Y \xrightarrow{\varphi} Y'$ is generically injective, and Y is the normalization of Y' . Corollary 7.6.3 computes the cohomology of Y' : $\mathbf{h}^0\mathcal{O}_{Y'} = \mathbf{h}^1\mathcal{O}_{Y'} = 1$. This tells us that $\mathbf{h}^q\mathcal{O}_{Y'} = \mathbf{h}^q\mathcal{O}_Y$ for all q . Let's denote the direct image of \mathcal{O}_Y by the same symbol \mathcal{O}_Y , and let \mathcal{F} be the $\mathcal{O}_{Y'}$ -module $\mathcal{O}_Y/\mathcal{O}_{Y'}$. The exact sequence $0 \rightarrow \mathcal{O}_{Y'} \rightarrow \mathcal{O}_Y \rightarrow \mathcal{F} \rightarrow 0$ shows that $\mathbf{h}^0\mathcal{F} = 0$. Since Y is the normalization of Y' , \mathcal{F} is a torsion module with no global sections. So $\mathcal{F} = 0$, and $Y \approx Y'$. □

8.8.11. Corollary. *Every elliptic curve is isomorphic to a cubic curve in \mathbb{P}^2 .* □

*genu-
sonecubic*

(8.8.12) the group law on an elliptic curve

*genusone-
group*

The points of an elliptic curve form an abelian group, once one chooses a point to be the identity element.

We choose a point of an elliptic curve Y and label it o . We'll write the law of composition in the group as $p \oplus q$, using the symbol \oplus to distinguish the sum in the group, ca point of Y , from the divisor $p + q$.

Let p and q be points of Y . To define $p \oplus q$, we compute the cohomology of $\mathcal{O}_Y(p + q - o)$. It follows from Riemann-Roch that $\mathbf{h}^0 \mathcal{O}_Y(p + q - o) = 1$ and that $\mathbf{h}^1 \mathcal{O}_Y(p + q - o) = 0$. There is a nonzero function f , unique up to scalar factor, with simple poles at p and q and a simple zero at o . This function has exactly one additional zero. That zero is defined to be the sum $p \oplus q$ in the group. In terms of linearly equivalent divisors, $s = p \oplus q$ is the unique point such that $p + q$ is linearly equivalent to $o + s$.

grplaw **8.8.13. Proposition.** *The law of composition \oplus defined above makes an elliptic curve into an abelian group.*

The proof is an exercise. □

maptoP **(8.8.14) interlude: maps to projective space**

Let Y be a smooth projective curve. We have seen that any set (f_0, \dots, f_n) of rational functions on Y , not all zero, defines a morphism $Y \xrightarrow{\varphi} \mathbb{P}^n$ (5.3.3). As a reminder, let q be a point of Y and let $g_j = f_j/f_i$, where i is an index such that f_i has the minimum value $v_q(f_i)$. Then g_j are regular at q for all j , and the morphism φ sends the point q to $(g_0(q), \dots, g_n(q))$. For example, the inverse image $\varphi^{-1}(\mathbb{U}^0)$ of the standard open set \mathbb{U}^0 is the set of points of Y at which the functions $g_j = f_j/f_0$ are regular. If q is such a point, then $\varphi(q) = (1, g_1(q), \dots, g_n(q))$.

mapcurve **8.8.15. Lemma.** *Let Y be a smooth projective curve, and let $Y \xrightarrow{\varphi} \mathbb{P}^n$ be the morphism to projective space that is defined by some set (f_0, \dots, f_n) of rational functions on Y that aren't all zero.*

- (i) *If the subspace of the function field of Y that is spanned by $\{f_0, \dots, f_n\}$ has dimension at least two, then φ is not a constant function.*
- (ii) *If $\{f_0, \dots, f_n\}$ are linearly independent, the image isn't contained in any hyperplane.* □

The *degree* d of a nonconstant morphism $Y \xrightarrow{\varphi} \mathbb{P}^n$ from a projective curve Y , smooth or not, to projective space is the number of points of the inverse image $\varphi^{-1}H$ of a generic hyperplane H in \mathbb{P}^n . You can check that this number is well-defined.

basept **(8.8.16) base points**

Let D be a divisor on the smooth projective curve Y , such that $\mathbf{h}^0 \mathcal{O}(D) = k > 1$. A basis (f_0, \dots, f_k) of global sections of $\mathcal{O}(D)$ defines a morphism $Y \rightarrow \mathbb{P}^{k-1}$. This is the most common way to construct a morphism to projective space, though one could use any set of rational functions.

If a global section of $\mathcal{O}(D)$ vanishes at a point p of Y , it is a global section of $\mathcal{O}(D-p)$. A point p is a *base point* of $\mathcal{O}(D)$ if every global section of $\mathcal{O}(D)$ vanishes at p . A base point can be described in terms of the usual exact sequence

$$0 \rightarrow \mathcal{O}(D-p) \rightarrow \mathcal{O}(D) \rightarrow \epsilon \rightarrow 0$$

The point p is a base point if $\mathbf{h}^0 \mathcal{O}(D-p) = \mathbf{h}^0 \mathcal{O}(D)$, or if $\mathbf{h}^1 \mathcal{O}(D-p) = \mathbf{h}^1 \mathcal{O}(D) - 1$.

deg-nobasept **8.8.17. Lemma.** *Let D be a divisor on a smooth projective curve Y , and suppose that $\mathbf{h}^0 \mathcal{O}(D) > 1$. Let $Y \xrightarrow{\varphi} \mathbb{P}^n$ be the morphism defined by a basis of global sections.*

- (i) *The image of φ isn't contained in any hyperplane.*
- (ii) *If $\mathcal{O}(D)$ has no base points, the degree r of the morphism φ is equal to degree of D . If there are base points, the degree is lower.* □

canondiv **(8.8.18) canonical divisors**

Because the module Ω_Y of differentials on a smooth curve Y is invertible, it is isomorphic to $\mathcal{O}(K)$ for some divisor K . Such a divisor K is called a *canonical divisor*. The degree of K is $2g - 2$ (8.8.2). It is often convenient to represent Ω_Y as a module $\mathcal{O}(K)$, though the canonical divisor K isn't unique. It is determined only up to linear equivalence (see (8.2.13)).

When written in terms of a canonical divisor K , the Serre dual of an invertible module $\mathcal{O}(D)$ will be $\mathcal{O}(D)^\# = \mathcal{O}(\mathcal{O}(D), \mathcal{O}(K)) \approx \mathcal{O}(K-D)$. With this notation, the Riemann-Roch Theorem for $\mathcal{O}(D)$ becomes

$$(8.8.19) \quad \mathbf{h}^0\mathcal{O}(D) = \mathbf{h}^1\mathcal{O}(K-D) \quad \text{and} \quad \mathbf{h}^1\mathcal{O}(D) = \mathbf{h}^0\mathcal{O}(K-D) \quad \square \quad \text{RRforOD}$$

8.8.20. Proposition. *Let K be a canonical divisor on a smooth projective curve Y of genus $g > 0$.*

(i) $\mathcal{O}(K)$ has no base point.

(ii) Every point p of Y is a base point of $\mathcal{O}(K+p)$.

*exbase-
points*

proof. (i) Let p be a point of Y . We apply Riemann-Roch to the exact sequence

$$0 \rightarrow \mathcal{O}(K-p) \rightarrow \mathcal{O}(K) \rightarrow \epsilon \rightarrow 0$$

where ϵ denotes a one-dimensional module supported on a point p . The Serre duals of $\mathcal{O}(K)$ and $\mathcal{O}(K-p)$ are \mathcal{O} and $\mathcal{O}(p)$, respectively. They form an exact sequence

$$0 \rightarrow \mathcal{O} \rightarrow \mathcal{O}(p) \rightarrow \epsilon' \rightarrow 0$$

When Y has positive genus, there is no rational function on Y with just one simple pole. So $\mathbf{h}^0\mathcal{O}(p) = 1$. Riemann-Roch tells us that $\mathbf{h}^1\mathcal{O}(K-p) = 1$. Also, $\mathbf{h}^1\mathcal{O}(K) = 1$. The cohomology sequence

$$0 \rightarrow H^0(\mathcal{O}(K-p)) \rightarrow H^0(\mathcal{O}(K)) \rightarrow [1] \rightarrow H^1(\mathcal{O}(K-p)) \rightarrow H^1(\mathcal{O}(K)) \rightarrow 0$$

shows that $\mathbf{h}^0\mathcal{O}(K-p) = \mathbf{h}^0\mathcal{O}(K) - 1$. So p is not a base point.

(ii) Here, the relevant sequence is

$$0 \rightarrow \mathcal{O}(K) \rightarrow \mathcal{O}(K+p) \rightarrow \epsilon_3 \rightarrow 0$$

The Serre dual of $\mathcal{O}(K+p)$ is $\mathcal{O}(-p)$, which has no global section. Therefore $\mathbf{h}^1\mathcal{O}(K+p) = 0$, while $\mathbf{h}^1\mathcal{O}(K) = \mathbf{h}^0\mathcal{O} = 1$. The cohomology sequence

$$0 \rightarrow \mathbf{h}^0\mathcal{O}(K) \rightarrow \mathbf{h}^0\mathcal{O}(K+p) \rightarrow [1] \rightarrow \mathbf{h}^1\mathcal{O}(K) \rightarrow \mathbf{h}^1\mathcal{O}(K+p) \rightarrow 0$$

shows that $H^0(\mathcal{O}(K+p)) = H^0(\mathcal{O}(K))$. So p is a base point of $\mathcal{O}(K+p)$. □

(8.8.21) hyperelliptic curves

hyper

A *hyperelliptic curve* Y is a smooth projective curve of genus $g > 1$ that can be represented as a branched double covering of the projective line. So Y is hyperelliptic if there exists a morphism $Y \xrightarrow{\pi} X$ of degree two, with $X = \mathbb{P}^1$. Justification for the strange term 'hyperelliptic' is that every elliptic curve can be represented as a double cover of \mathbb{P}^1 , by the map to \mathbb{P}^1 defined by the global sections of $\mathcal{O}(2p)$.

The topological Euler characteristic of a hyperelliptic curve Y can be computed in terms of the covering $Y \rightarrow X$, which will be branched at a finite set, say of n points. Since π has degree two, the multiplicity of a branch point will be 2. The Euler characteristic is therefore $e(Y) = 2e(X) - n = 4 - n$. Since we know that $e(Y) = 2 - 2g$, the number n of branch points is $2g + 2$. When $g = 3$, $n = 8$.

It would take some experimentation to guess that the next remarkable theorem might be true, and to find a proof.

hyper-
canon

8.8.22. Theorem. Let K be a canonical divisor on a hyperelliptic curve Y , and let $Y \xrightarrow{\pi} X = \mathbb{P}^1$ be the associated branched covering of degree 2. Let $Y \xrightarrow{\kappa} \mathbb{P}^{g-1}$ be the morphism defined by the global sections of $\Omega_Y = \mathcal{O}(K)$. This morphism κ factors through X : There is a morphism $X \xrightarrow{u} \mathbb{P}^{g-1}$ such that κ is the composition $u \circ \pi$:

$$\begin{array}{ccc} Y & \xrightarrow{\pi} & X \\ \kappa \downarrow & & \downarrow u \\ \mathbb{P}^{g-1} & \xlongequal{\quad} & \mathbb{P}^{g-1} \end{array}$$

oned-
blcover

8.8.23. Corollary. A curve of genus $g \geq 2$ can be presented as a branched covering of \mathbb{P}^1 of degree 2 in at most one way. \square

proof of Theorem 8.8.22.

Let x be an affine coordinate in X , so that the standard affine open subset \mathbb{U}^0 of X is $\text{Spec } \mathbb{C}[x]$. We suppose that the point p_∞ at infinity of X isn't a branch point of the covering. Let $Y^0 = \pi^{-1}\mathbb{U}^0$. Then Y^0 will have an equation of the form

$$y^2 = f(x)$$

where f is a polynomial with $n = 2g + 2$ simple roots. There will be two points of Y above the point p_∞ . They are interchanged by the automorphism $y \rightarrow -y$. Let's call those points q_1 and q_2 .

We start with the differential dx , which we view as a differential on Y . Then $2y dy = f'(x)dx$. Since f has simple roots, f' doesn't vanish at any of them. Therefore dx has simple zeros on Y above the roots of f , the points at which $y = 0$. We also have a regular function on Y^0 with simple roots at those points, namely the function y . Therefore the differential $\omega = \frac{dx}{y}$ is regular and nowhere zero on Y^0 . Because the degree of a differential on Y is $2g - 2$, ω has a total of $2g - 2$ zeros at infinity. By symmetry, ω has zeros of order $g - 1$ at each of two points q_1 and q_2 . So $K = (g-1)q_1 + (g-1)q_2$ is a canonical divisor on Y , i.e., $\Omega_Y \approx \mathcal{O}_Y(K)$.

Since K has zeros of order $g - 1$ at infinity, the rational functions $1, x, x^2, \dots, x^{g-1}$, when viewed as functions on Y , are among the global sections of $\mathcal{O}_Y(K)$. They are independent, and there are g of them. Since $h^0\mathcal{O}_Y(K) = g$, they form a basis of $H^0(\mathcal{O}_Y(K))$. The map $Y \rightarrow \mathbb{P}^{g-1}$ defined by the global sections of $\mathcal{O}_Y(K)$ evaluates these powers of x , so it factors through X . \square

canonemb

(8.8.24) canonical embedding

Let Y be a smooth projective curve of genus $g \geq 2$, and let K be a canonical divisor on Y . Since $\mathcal{O}(K)$ has no base point (8.8.20), its global sections define a morphism $Y \rightarrow \mathbb{P}^{g-1}$ that is called the *canonical map*. Let's denote the canonical map by κ . The degree of κ is the degree $2g - 2$ of the canonical divisor.

canonem-
btwo

8.8.25. Theorem. Let Y be a smooth projective curve of genus g at least two. If Y isn't hyperelliptic, the canonical map embeds Y as a closed subvariety of projective space \mathbb{P}^{g-1} .

proof. We show first that, if the canonical map $Y \xrightarrow{\kappa} \mathbb{P}^{g-1}$ isn't injective, then Y is hyperelliptic. Let p and q be distinct points of Y such that $\kappa(p) = \kappa(q)$. We choose an effective canonical divisor such that p and q aren't in its support. We inspect the global sections of $\mathcal{O}(K - p - q)$. Since $\kappa(p) = \kappa(q)$, any global section of $\mathcal{O}(K)$ that vanishes at p vanishes at q too. Therefore $\mathcal{O}(K - p)$ and $\mathcal{O}(K - p - q)$ have the same global sections, and q is a base point of $\mathcal{O}(K - p)$. We've computed the cohomology of $\mathcal{O}(K - p)$ before: $h^0\mathcal{O}(K - p) = g - 1$ and $h^1\mathcal{O}(K - p) = 1$. Then $h^0\mathcal{O}(K - p - q) = g - 1$ and $h^1\mathcal{O}(K - p - q) = 2$. The Serre dual of $\mathcal{O}(K - p - q)$ is $\mathcal{O}(p + q)$, so by Riemann-Roch, $h^0\mathcal{O}(p + q) = 2$. If D is a divisor of degree one on a curve of positive genus, then $h^0\mathcal{O}(D) \leq 1$ (Proposition 8.8.10). Therefore $\mathcal{O}(p + q)$ has no base point. Its global sections define a morphism $Y \rightarrow \mathbb{P}^1$ of degree 2. So Y is hyperelliptic.

If Y isn't hyperelliptic, the canonical map is injective, so Y is mapped bijectively to its image Y' in \mathbb{P}^{g-1} . This almost proves the theorem. But: can Y' have a cusp? We must show that the bijective map $Y \xrightarrow{\kappa} Y'$ is an isomorphism.

We go over the computation made above for a pair of points p, q , this time taking $q = p$. The computation is the same. Since Y isn't hyperelliptic, p isn't a base point of $\mathcal{O}_Y(K - p)$. Therefore $h^0\mathcal{O}_Y(K - 2p) = h^0\mathcal{O}_Y(K - p) - 1$. This tells us that there is a global section f of $\mathcal{O}_Y(K)$ that has a zero of order exactly 1 at

p . When properly interpreted, this fact shows that κ doesn't collapse any tangent vectors to Y , and that κ is an isomorphism. Since we haven't discussed tangent vectors, we prove this directly.

Since κ is bijective, the function fields of Y and its image Y' are equal, and Y is the normalization of Y' . Moreover, κ is an isomorphism except on a finite set. We work locally at a point p' of Y' , and we denote the unique point of Y that maps to Y' by p . When we restrict the global section f of $\mathcal{O}_Y(K)$ found above to the image Y' , we obtain an element of the maximal ideal $\mathfrak{m}'_{p'}$ of $\mathcal{O}_{Y'}$ at p' , that we denote by x . On Y , this element has a zero of order one at p , and therefore it is a local generator for the maximal ideal \mathfrak{m}_p of \mathcal{O}_Y . Let \mathcal{O}' and \mathcal{O} be the local rings at p . We apply the Local Nakayama Lemma 5.1.16, regarding \mathcal{O} as a finite \mathcal{O}' -module. We substitute $V = \mathcal{O}$ and $M = \mathfrak{m}'_{p'}$ into the statement of that lemma. Since x is in $\mathfrak{m}'_{p'}$, $V/MV = \mathcal{O}/\mathfrak{m}'_{p'}\mathcal{O}$ is the residue field $k(p)$ of \mathcal{O} , which is spanned, as \mathcal{O}' -module, by the element 1. The Local Nakayama Lemma tells us that \mathcal{O} is spanned, as \mathcal{O}' -module, by 1, and this shows that $\mathcal{O} = \mathcal{O}'$. \square

(8.8.26) some curves of low genus

lowgenus

Here Y will denote a smooth projective curve of genus g .

curves of genus 2.

When the genus of a smooth projective curve Y is 2, then $2g - 2 = 2$. The canonical map κ is a map of degree 2 from Y to \mathbb{P}^1 . Every smooth projective curve of genus 2 is hyperelliptic.

curves of genus 3.

Let Y be a smooth projective curve of genus $g = 3$. The canonical map κ is a morphism of degree 4 from Y to \mathbb{P}^2 . If Y isn't hyperelliptic, its image will be a plane curve of degree 4 that is isomorphic to Y . The genus of a smooth projective curve of degree 4 is $\binom{3}{2} = 3$ (1.8.25), which checks.

There is a second way to arrive at the same result. We go through it because the same method can be used for curves of genus 4 or 5.

Riemann-Roch determines the dimension of the space of global sections of $\mathcal{O}(dK)$:

$$h^1\mathcal{O}(dK) = h^0\mathcal{O}((1-d)K) = 0$$

, when $d > 1$. For such d ,

$$(8.8.27) \quad h^0\mathcal{O}(dK) = \text{deg}(dK) + 1 - g = d(2g - 2) - (g - 1) = (2d - 1)(g - 1)$$

OdK

In our case $g = 3$, so $h^0\mathcal{O}(dK) = 4d - 2$ when $d > 1$.

The number of monomials of degree d in $n + 1$ variables x_0, \dots, x_n is $\binom{n+d}{d}$. Here $n = 2$, so the number is $\binom{d+2}{2}$.

We assemble this information into a table:

d	0	1	2	3	4	5
monos deg d	1	3	6	10	15	21
$h^0\mathcal{O}(dK)$	1	3	6	10	14	18

Now, if $(\alpha_0, \dots, \alpha_2)$ is a basis of $H^0\mathcal{O}(K)$, the products $\alpha_{i_1} \cdots \alpha_{i_d}$ of length d are global sections of $\mathcal{O}(dK)$. In fact, they generate the space $H^0\mathcal{O}(dK)$ of global sections. This isn't very important here, so we omit the proof. What we see from the table is that there is at least one homogeneous polynomial $f(x_0, \dots, x_2)$ of degree 4 such that $f(\alpha) = 0$. This means that the curve Y lies in the zero locus of that polynomial, which is a quartic curve. In fact, Y is this quartic curve, so f is, up to scalar factor, the only homogeneous quartic that vanishes on Y . Therefore the monomials of degree 4 in α span a space of dimension 14, and therefore they span $H^0\mathcal{O}(4K)$. This is one case of the general fact that was stated above.

The table also shows that there are (at least) three independent polynomials of degree 5 that vanish on Y . They don't give new relations because we know three such polynomials, namely x_0f, x_1f, x_2f .

curves of genus 4.

When Y is a smooth projective curve of genus 4 and is not hyperelliptic, the canonical map embeds Y as a curve of degree $2g - 2 = 6$ in \mathbb{P}^3 . Let's leave the analysis of this case as an exercise.

curves of genus 5.

With genus 5, things become more complicated.

Let Y be a smooth projective curves of genus 5 that isn't hyperelliptic. The canonical map embeds Y as a curve of degree 8 in \mathbb{P}^4 . We make a computation analogous to what was done for genus 3.

For $d > 1$, the dimension of the space of global sections of $\mathcal{O}(dK)$ is

$$h^0\mathcal{O}(dK) = (2d - 1)(g - 1) = 8d - 4$$

The number of monomials of degree d in 5 variables is $\binom{d+4}{4}$.

We form a table:

d	0	1	2	3
monos deg d	1	5	15	35
$h^0\mathcal{O}(dK)$	1	5	12	20

This table predicts that there are (at least) three independent homogeneous quadratic polynomials q_1, q_2, q_3 that vanish on the curve Y .

Let H_1, H_2, H_3 be hypersurfaces in \mathbb{P}^4 , of degrees r_1, r_2, r_3 , respectively. If the intersection $Z = H_1 \cap H_2 \cap H_3$ has dimension 1, it is called a *complete intersection*. Bézout's Theorem has a generalization that applies here. If Z is a complete intersection, its *degree*, the number of intersections of Z with a generic hyperplane, will be the product $r_1 r_2 r_3$. The proof is analogous to that of the usual Bézout's Theorem. We set the proof up below, leaving details as an exercise.

Thus, when Q_i is the quadric $q_i = 0$, the intersection $Z = Q_1 \cap Q_2 \cap Q_3$ will have degree $2^3 = 8$ and it will contain Y , also of degree 8. Then Y will be equal to Z , and will be complete intersection.

However, it is possible that the three quadrics intersect in a subset of dimension 2, and in this case the canonically embedded curve Y isn't a complete intersection.

A curve which can be obtained as a three-sheeted covering of \mathbb{P}^1 is called a *trigonal curve* (another peculiar term).

trigonal **8.8.28. Proposition.** *A trigonal curve of genus 5 is not isomorphic to an intersection of three quadrics in \mathbb{P}^4 .*

proof. A trigonal curve Y will have a degree three morphism to the projective line: $Y \rightarrow X = \mathbb{P}^1$. Let's suppose that the point at infinity of X isn't a branch point. Let the fibre over the point at infinity be $\{p_1, p_2, p_3\}$. With coordinates (x_0, x_1) on X , the rational function $u = x_1/x_0$ on X has poles $D = \sum p_i$ on Y , so $H^0(Y, \mathcal{O}(D))$ contains 1 and u , and therefore $h^0\mathcal{O}(D) \geq 2$. By Riemann-Roch, $\chi\mathcal{O}(D) = 3 + 1 - g = -1$. so $h^1\mathcal{O}(D) = h^0\mathcal{O}(K - D) \geq 3$. There are three independent global sections of $\mathcal{O}(K)$ that vanish on D . Let them be $\alpha_0, \alpha_1, \alpha_2$. Then, when Y is embedded into \mathbb{P}^4 by a basis $(\alpha_0, \dots, \alpha_4)$, the three planes $\{x_i = 0\}$, $i = 0, 1, 2$ contain D . The intersection of these planes is a line L that contains the three points D .

We go back to the three quadrics Q_1, Q_2, Q_3 that contain Y . Since they contain Y , they contain D . A quadric Q intersects the line L in two points unless $L \subset Q$. Therefore each of the quadrics Q_i contains L , and $Q_1 \cap Q_2 \cap Q_3$ contains L as well as Y . According to Bézout, the intersection of three quadrics, if it is one-dimensional, will have degree $2^3 = 8$. But Y has degree 8 and L has degree 1, and $8 + 1 = 9$ is too big. Therefore $Q_1 \cap Q_2 \cap Q_3$ has dimension 2. \square

It can be shown that this is the only exceptional case. A curve of genus 5 is either hyperelliptic, or trigonal, or else it is a complete intersection of three quadrics in \mathbb{P}^4 . However, this requires more work.

bezouttwo **(8.8.29) Bézout's Theorem, version 2**

beztwo **8.8.30. Theorem.** *Let H_1, H_2, H_3 be hypersurfaces in \mathbb{P}^r of degrees ℓ, m, n , such that the intersection $Z = H_1 \cap H_2 \cap H_3$ has dimension $r - 3$. Then the degree of Z is the product ℓmn .*

We slice \mathbb{P}^r , H_i , and Z with a generic linear subspace L of \mathbb{P}^r of dimension 3. So L is a projective space of dimension 3. The degree of Z is defined to be the number of points of the intersection $L \cap Z$, and $L \cap H_i$ are surfaces in \mathbb{P}^3 , of degrees ℓ, m, n . We replace \mathbb{P}^r by L , H_i by $H_i \cap Z$, and Z by $L \cap Z$. This reduces us to proving the theorem when $r = 3$. We restate the theorem for that case.

8.8.31. Theorem. *Let H_1, H_2, H_3 be surfaces in \mathbb{P}^3 of degrees ℓ, m, n , respectively, such that the intersection $Z = H_1 \cap H_2 \cap H_3$ has dimension zero. The number of intersection points, counted with multiplicity, is ℓmn .*

Setup for the proof. Say that the surfaces H_i are the zero loci of the homogenous polynomials f, g, h , respectively. Let \mathcal{O} be the structure sheaf on \mathbb{P}^3 . We form the quotient $\overline{\mathcal{O}} = \mathcal{O}/(f, g, h)$. Its support will be the finite set Z . We want to show that the dimension of $\overline{\mathcal{O}}$ as vector space is the product ℓmn .

The notation $\overline{\mathcal{O}} = \mathcal{O}/(f, g, h)$ isn't precise. We should really write $\mathcal{O} = \mathcal{O}/\mathcal{I}$, where \mathcal{I} is the ideal $\mathcal{O}(-\ell)f + \mathcal{O}(-m)g + \mathcal{O}(-n)h$.

We form a resolution of $\overline{\mathcal{O}}$ analogous to the resolution (7.8.3):

$$0 \rightarrow \mathcal{O}(-\ell-m-n) \xrightarrow{A} \mathcal{O}(-m-n) \oplus \mathcal{O}(-\ell-n) \oplus \mathcal{O}(-\ell-m) \xrightarrow{B} \mathcal{O}(-\ell) \oplus \mathcal{O}(-m) \oplus \mathcal{O}(-n) \xrightarrow{C} \mathcal{O} \rightarrow \overline{\mathcal{O}} \rightarrow 0$$

where $A = \begin{pmatrix} f \\ g \\ h \end{pmatrix}$, $B = \begin{pmatrix} 0 & h & -g \\ -h & 0 & f \\ g & -f & 0 \end{pmatrix}$, and $C = (f \ g \ h)$.

The maps are given by matrix multiplication, with A, B, C operating on the left, and with the direct sums represented as columns.

It is an exercise to show that this sequence is exact provided that the intersection has dimension zero. It shows that $\chi(\overline{\mathcal{O}})$ is independent of f, g, h . When f, g, h are generic linear polynomials, there is just one point of intersection, the theorem is true in that case, and it follows when f, g, h are products of generic linear polynomials. Therefore it is true in all cases. (Or, one can evaluate the alternating sum of the Euler characteristics of the terms.)

8.9 Exercises

change-
blowup-
texting

8.9.1. (Chap 8)??? Let $X = \text{Spec } A$ be an affine curve, with $A = \mathbb{C}[x_0, \dots, x_n]/P$, and let x_i also denote the residues of the variables in A . Let p be a point of X . We adjust coordinate so that p is the origin $(0, \dots, 0)$, and we form the subalgebra B of the function field K of A that is generated by x_0 and the ratios $z_i = x_i/x_0$, $i = 1, \dots, n$. So $B = \mathbb{C}[x_0, z_1, z_2, \dots, z_n]$. Let $Y = \text{Spec } B$. The inclusion $A \subset B$ defines a morphism $Y \rightarrow X$ called the *blowup* of p in X . There will be finitely many points of Y in the fibre over p , and if coordinates are generic, there will be at least one such point, say q . We replace X by Y and p by q . Prove that this blowing up process yields a curve that is smooth above p in finitely many steps.

bertinifor-
pencil

8.9.2. (*Bertini for pencil in \mathbb{A}^2*) Show that if $f(x, y)$ is polynomial and if d divides f_x and f_y , then f is constant on the locus $d = 0$.

8.9.3. prove twisted cubic is smooth both ways.

8.9.4. an open subset of an affine curve is affine.

xproveBG

8.9.5. The projective line $X = \mathbb{P}^1$ with coordinates x_0, x_1 is covered by the two standard affine open sets $U^0 = \text{Spec } R_0$ and $U^1 = \text{Spec } R_1$, $R_0 = \mathbb{C}[u]$ with $u = x_1/x_0$, and $R_1 = \mathbb{C}[v]$ with $v = x_0/x_1 = u^{-1}$. The intersection U^{01} is the spectrum of the Laurent polynomial ring $R_{01} = \mathbb{C}[u, v] = \mathbb{C}[u, u^{-1}]$. The units of R_{01} are the monomials cu^k , where k can be any integer.

(a) Let $A = \begin{pmatrix} a & b \\ c & d \end{pmatrix}$ be an invertible R_{01} -matrix. Prove that there is an invertible R_0 -matrix Q and there is an invertible R_1 -matrix P such that $Q^{-1}AP$ is diagonal.

(b) Use part (a) to prove the Birkhoff-Grothendieck Theorem for torsion-free \mathcal{O}_X -modules of rank 2.

BGmatr

8.9.6. Prove the Birkhoff-Grothendieck Theorem by matrix manipulation, as outlined here.

Let $U^0 = \text{Spec } A_0$ and $U^1 = \text{Spec } A_1$ be the standard cover of \mathbb{P}^1 , and let the intersection be $U^{01} = \text{Spec } A_{01}$, where $A_0 = \mathbb{C}[u]$, $A_1 = \mathbb{C}[u^{-1}]$, and $A_{01} = \mathbb{C}[u, u^{-1}]$. Given a locally free \mathcal{O} -module on \mathbb{P}^1 , let $M_0 = \mathcal{M}(U^0)$, $M_1 = \mathcal{M}(U^1)$, and $M_{01} = \mathcal{M}(U^{01})$. Then M_i free A_i -modules, for $i = 0, 1, 01$. Let \mathbf{B}_0 and \mathbf{B}_1 be bases for M_0 and M_1 . Both of these sets will be bases of M_{01} , that are related by an invertible A_{01} -matrix R . We can change the basis \mathbf{B}_0 by an invertible A_0 -matrix Q and the basis \mathbf{B}_1 by an invertible A_1 -matrix P . If we do this, R gets replaced by

qinversmp

$$(8.9.7) \quad R' = Q^{-1}RP$$

in which Q and P can be arbitrary elements of $GL_n(A_0)$ and $GL_n(A_1)$. Show that for any element R of $GL_n(A_{01})$, there exist elements Q in $GL_n(A_0)$ and P in $GL_n(A_1)$ such that $Q^{-1}RP$ is diagonal.

xproveBG

8.9.8. The projective line $X = \mathbb{P}^1$ with coordinates x_0, x_1 is covered by the two standard affine open sets $U^0 = \text{Spec } R_0$ and $U^1 = \text{Spec } R_1$, $R_0 = \mathbb{C}[u]$ with $u = x_1/x_0$, and $R_1 = \mathbb{C}[v]$ with $v = x_0/x_1 = u^{-1}$. The intersection U^{01} is the spectrum of the Laurent polynomial ring $R_{01} = \mathbb{C}[u, v] = \mathbb{C}[u, u^{-1}]$. The units of R_{01} are the monomials cu^k , where k can be any integer.

(a) Let $A = \begin{pmatrix} a & b \\ c & d \end{pmatrix}$ be an invertible R_{01} -matrix. Prove that there is an invertible R_0 -matrix Q and there is an invertible R_1 -matrix P such that $Q^{-1}AP$ is diagonal.

(b) Use part (a) to prove the Birkhoff-Grothendieck Theorem for torsion-free \mathcal{O}_X -modules of rank 2.

BGmatr

8.9.9. Prove the Birkhoff-Grothendieck Theorem by matrix manipulation, as outlined here.

Let $U^0 = \text{Spec } A_0$ and $U^1 = \text{Spec } A_1$ be the standard cover of \mathbb{P}^1 , and let the intersection be $U^{01} = \text{Spec } A_{01}$, where $A_0 = \mathbb{C}[u]$, $A_1 = \mathbb{C}[u^{-1}]$, and $A_{01} = \mathbb{C}[u, u^{-1}]$. Given a locally free \mathcal{O} -module on \mathbb{P}^1 , let $M_0 = \mathcal{M}(U^0)$, $M_1 = \mathcal{M}(U^1)$, and $M_{01} = \mathcal{M}(U^{01})$. Then M_i free A_i -modules, for $i = 0, 1, 01$. Let \mathbf{B}_0 and \mathbf{B}_1 be bases for M_0 and M_1 . Both of these sets will be bases of M_{01} , that are related by an invertible A_{01} -matrix R . We can change the basis \mathbf{B}_0 by an invertible A_0 -matrix Q and the basis \mathbf{B}_1 by an invertible A_1 -matrix P . If we do this, R gets replaced by

qinversmp

$$(8.9.10) \quad R' = Q^{-1}RP$$

in which Q and P can be arbitrary elements of $GL_n(A_0)$ and $GL_n(A_1)$. Show that for any element R of $GL_n(A_{01})$, there exist elements Q in $GL_n(A_0)$ and P in $GL_n(A_1)$ such that $Q^{-1}RP$ is diagonal.

- 8.9.11.** On \mathbb{P}^1 , when is $\mathcal{O}(m) \oplus \mathcal{O}(n)$ isomorphic to $\mathcal{O}(r) \oplus \mathcal{O}(s)$? xOmplu-
sOn
xOisum
- 8.9.12.** Let Y be a smooth curve of genus g . Start with a positive divisor E of degree $2g - 1$. Then $\mathbf{h}^0(\mathcal{O}(E)) = g$ and $\mathbf{h}^1(\mathcal{O}(E)) = 0$.
Subtracting $g - 1$ generic points gives divisor D of degree g with $\mathbf{h}^0(\mathcal{O}(D)) = 1$ and $\mathbf{h}^1(\mathcal{O}(D)) = 0$. Let $(1, y)$ be a basis of $\mathbf{h}^0(\mathcal{O}(D))$. This gives a map $Y \rightarrow X = \mathbb{P}^1$ of degree g . Taking direct image, \mathcal{O}_Y becomes an \mathcal{O}_X -module of rank g . The inclusion $\mathcal{O}_X \subset \mathcal{O}_Y$ splits. So $\mathcal{O}_Y = \mathcal{O}_X \oplus \mathcal{L}$ for some locally free modules \mathcal{L} of rank $g - 1$. We have $\mathbf{h}^0(\mathcal{O}_Y) = 1$ and $\mathbf{h}^1(\mathcal{O}_Y) = 0$, so $\mathbf{h}^0(\mathcal{L}) = \mathbf{h}^1(\mathcal{L}) = 0$. Since \mathcal{L} is a direct sum of twisting modules, the only possibility is that $\mathcal{O}_Y = \mathcal{O}_X \oplus \mathcal{O}_X(-1)^{g-1}$.
- 8.9.13.** Let A be a finite-type domain. xde-
somega
- (a) Let $B = A[x]$ be the ring of polynomials in one variable with coefficients in A . Describe the module Ω_B in terms of Ω_A .
- (b) Let s be a nonzero element of A and let A' be the localization $A[x]/(sx - 1)$. Describe the module $\Omega_{A'}$.
- 8.9.14.** Let Y be a smooth curve of genus 1. Use version 1 of Riemann-Roch to prove that, if $r \geq 1$, then $\dim H^0(Y, \mathcal{O}_Y(rp)) = r$ and $H^1(Y, \mathcal{O}_Y(rp)) = 0$. xgenone
- 8.9.15.** Let $Y \xrightarrow{\pi} X$ be a branched covering of smooth affine curves, $X = \text{Spec } A$ and $Y = \text{Spec } B$, and let $B \xrightarrow{\delta} {}_A(B, \Omega_A)$ be the composition of the derivation $B \xrightarrow{d} \Omega_B$ with the trace map $\Omega_B \approx_B (B, \Omega_B) \xrightarrow{\tau \circ} {}_A(B, \Omega_A)$. Prove that δ is a derivation from B to the B -module ${}_A(B, \Omega_A)$.
- 8.9.16.** Determine the number of points of order 2 on an elliptic curve. xptsor-
dertwo
xnumber-
flex
- 8.9.17.** Let C be a smooth plane cubic curve. Show if origin is a flex point the other the flexes of C are the points of order 3. Therefore there are eight points of order 3.
- 8.9.18.** ## there is something wrong here## Let Y be a smooth curve of genus $g > 0$, and let E be a divisor of degree $2g - 1$ on Y . xgood-
genusg
- (i) Prove that $\mathbf{h}^0(\mathcal{O}(E)) = g$ and $\mathbf{h}^1(\mathcal{O}(E)) = 0$, and that if D is the divisor of degree g obtained by subtracting $g - 1$ generic points from E , then $\mathbf{h}^0(\mathcal{O}(D)) = 1$ and $\mathbf{h}^1(\mathcal{O}(D)) = 0$.
- (ii) A basis $(1, y)$ of $\mathbf{h}^0(\mathcal{O}(D))$ defines a map $Y \rightarrow X = \mathbb{P}^1$ of degree g , and the direct image of \mathcal{O}_Y becomes an \mathcal{O}_X -module of rank g . Show that the direct image \mathcal{O}_Y has the form $\mathcal{O}_X \oplus \mathcal{L}$ for some locally free module \mathcal{L} of rank $g - 1$.
- (iii) Prove that $\mathcal{L} \approx \mathcal{O}_X(-1)^{g-1}$.
- 8.9.19.** Let C and D be conics in \mathbb{P}^2 that meet in four distinct points, and let D^* be the dual conic of tangent lines to D . Let E be the locus of points (p, ℓ^*) in $\mathbb{P} \times \mathbb{P}^*$ such that $\ell^* \in D^*$ and $p \in \ell$. xpncelet
- (a) Prove that E is a smooth elliptic curve.
- (b) Show that, for most $p \in C$, there will be two tangent lines ℓ to D such that (p, ℓ^*) is in E , and that, for most $\ell^* \in D^*$, there will be two points p such that (p, ℓ^*) is in E . Identify the exceptional points.
- (c) If (p_1, ℓ_1) is given, let p_2 denote the second intersection of C with ℓ_1^* , and let ℓ_2^* denote the second tangent to D that contains p_2 . Define a map, where possible, by sending $(p_1, \ell_1^*) \rightarrow (p_2, \ell_1^*) \rightarrow (p_2, \ell_2^*)$. Show that this map extends to a morphism $E \xrightarrow{\gamma} E$ on E , and that this morphism is a translation $p \rightarrow p \oplus a$, for some point a of E .
- (d) It might happen that for some point p of C and some n , $\gamma^n(p) = p$. Show that if this occurs, the same is true for every point of C . For example, if $\gamma^3(p) = p$, the lines ℓ_1, ℓ_2, ℓ_3 will form a triangle whose vertices are on C , and this will be true for all points p of C . This is Poncelet's Theorem.
- 8.9.20.** Let $Y \rightarrow X$ be a branched covering, and let p be a point of X whose inverse image in Y consists of one point q . Use a basis to prove the main theorem on the trace map for differentials locally at p . xprove-
trace
- 8.9.21.** Let D be a divisor of degree d on a smooth projective curve Y . Show that $\mathbf{h}^0(\mathcal{O}(D)) \leq d + 1$, and if $\mathbf{h}^0(\mathcal{O}(D)) = d + 1$, then Y is a smooth rational curve, isomorphic to \mathbb{P}^1 . xsmrat
- 8.9.22.** How many real flex points can a real cubic curve have? xrealflex
- 8.9.23.** (i) Let C be plane curve of degree 5 with a double point. Show that the projection of the plane to $X = \mathbb{P}^1$ with the double point as center of projection represents C as a trigonal curve of genus 5. xdegfive

(ii) The canonical embedding of a trigonal genus 5 curve Y will have three colinear points $D = p_1 + p_2 + p_3$. Show that $h^0(\mathcal{O}(K - D)) = 3$ and that $\mathcal{O}(K - D)$ has no base point. Show that a basis of $H^0(\mathcal{O}(K - D))$ maps Y to a curve of degree 5 in \mathbb{P}^2 with a double point.

xellgrplaw

8.9.24. (*group law on an elliptic curve*) Let o, p , and q be points of an elliptic curve Y . Show that $\mathcal{O}_Y(p+q-o)$ has a nonzero global section that is unique up to scalar factor, and that has a unique zero. That zero is defined to be $p \oplus q$. Prove that, with the law of composition \oplus , Y becomes a commutative group.

xHonezero

8.9.25. Prove that a projective curve Y such that $h^1(\mathcal{O}_Y) = 0$, smooth or not, is isomorphic to the projective line \mathbb{P}^1 .

xgenustwo

8.9.26. Let Y be a smooth projective curve of genus 2.

(a) Determine the possible dimensions of $H^q(Y, \mathcal{O}(D))$, when D is an effective divisor of degree n .

(b) Let K be an effective canonical divisor. Then 1 is a global section of $\mathcal{O}(K)$, and there is also a nonconstant global section x . Prove that the pair of functions $(1, x)$ defines a morphism $Y \rightarrow \mathbb{P}^1$ that represents Y as a double cover of the projective line.

xnode-
sandcusps

8.9.27. Let C be a plane projective curve of degree d , with δ nodes and κ cusps, and let C' be the normalization of C . Determine the Genus of C' .

xmultbyf-
plusc

8.9.28. Let M be a module over a finite-type domain A , and let α be an element of A . Prove that for all but finitely many complex numbers c , scalar multiplication by $s = \alpha - c$ is an injective map $M \xrightarrow{s} M$.

xeuler-

8.9.29. Do Euler characteristic of complex.

compl
xMTV

8.9.30. Prove that, on a smooth curve, any finite module is the direct sum of its torsion submodule and a locally free module.

s

xgenust-
wotwo

8.9.31. Let Y be a curve of genus two, and let p be a point p of Y .

(a) Prove that there are two cases: Either $h^0(\mathcal{O}_Y(2p)) = 1$ and $H^1(\mathcal{O}_Y(2p)) = 0$, or else $h^0(\mathcal{O}_Y(2p)) = 2$ and $h^1(\mathcal{O}_Y(2p)) = 1$.

(b) Suppose we are in the first case. Show that then $h^0(\mathcal{O}_Y(rp)) = r - 1$ and $H^1(\mathcal{O}_Y(rp)) = 0$, for all $r \geq 2$.

(c) Show that when $r = 4$, there is a basis of global sections of $\mathcal{O}(4p)$ of the form $(1, x, y)$, where x and y have poles of orders 3 and 4 at p . This basis defines a morphism $Y \rightarrow \mathbb{P}^2$ whose image is a curve Y' of degree 4.

(d) Prove that Y' is a singular curve.

xmoduli

8.9.32. labelxmoduli *moduli of plane curves of degree d* . There are several dimensions:

- m , the dimension $\binom{d+2}{2}$ of the space of homogeneous polynomials of degree d ,
- g , the dimension of the group of linear operators on \mathbb{P}^2 , which is $\dim GL_3 - 1 = 8$, and
- a the dimension of the group of automorphisms of a generic curve C of degree d .

Putting these together, one can determine the number of moduli (parameters) of a generic curve of degree d . Do this degrees 1, 2, 3, and 4.

xmod-
dirsum

8.9.33. Prove that a finite \mathcal{O} -module on a smooth curve is a direct sum of a torsion module and a locally free module.

8.9.34. Let $Y = \text{Spec } B$ a smooth affine curve, $y \in B$. At what points does dy generate Ω_Y locally?

xgenomega
xgthree

8.9.35. Let Y be a smooth projective curve of genus three.

(a) Let $(1, x, y)$ be a basis for $H^0(Y, \mathcal{O}(K))$. Use Riemann-Roch for multiples of K to show that x, y satisfy a polynomial relation of degree at most 4.

(b) Let f be the morphism from Y to \mathbb{P}^2 defined by the rational functions $(1, x, y)$. Show that the image C of f is a plane curve of degree at most 4, and that if its degree is 4, then C is a smooth curve.

sm

8.9.36. A a domain, P_1, \dots, P_r and Q_1, \dots, Q_s prime ideals of A . Assume that for all i, j , $P_i \not\supseteq Q_j$. There exists an element $a \in A$ such that $a \in P_i$ for all i but $a \not\in Q_j$ for all j .

8.9.37. equations defining the degree part of $k[x, y, z]/z^2 - xy$, and proof that $O(1)$ is not free there.

8.9.38. Lemma: f irreducible in $\mathbb{C}[x]$, A finite-type domain. Then f irreducible in $A[x]$. (evaluate at a point)

8.9.39. Let A, B be 2×2 variable matrices, let P be the polynomial ring $\mathbb{C}[a_{ij}, b_{ij}]$. and let R be the algebra $P/(AB - BA)$. Show that R has a resolution as P -module of the form $0 \rightarrow P^2 \rightarrow P^3 \rightarrow P \rightarrow R \rightarrow 0$.

There are three equations depending only on the 6 variables $a_{12}, a_{21}, b_{12}, b_{21}, c = a_{11} - a_{22}, d = b_{11} - b_{22}$. There is one relation of degree 1 in a_{12}, a_{21}, c and one of degree 1 in b_{12}, b_{21}, d .

###

8.9.40. do this If \mathfrak{m}_j is the maximal ideal at the point q_j , the divisor that corresponds to the fractional ideal $\mathfrak{m}_1^{r_1} \cdots \mathfrak{m}_k^{r_k}$ is the combination $r_1 q_1 + \cdots + r_k q_k$.

8.9.41. Let $Y \xrightarrow{u} X$ be a finite morphism of curves, and let K and L be the function fields of X and Y , respectively, and suppose $[L : K] = n$. Then all fibres have order at most n , and all but finitely many fibres of Y over X have order equal to n .

8.9.42. Let $X = \mathbb{P}^1 \times \mathbb{P}^1$. We define a sheaf $\mathcal{O}_X(r, s)$ as follows: If U_i denote the standard affine open subsets of \mathbb{P}^1 , we have an affine open set $U_{00} = U_0 \times U_0 = \text{Spec } \mathbb{C}[u, v]$, where $u = x_1/x_0$ and $v = y_1/y_0$. The sections of $\mathcal{O}_X(r, s)$ on U_{00} are the ratios $h/x_0^k y_0^\ell$, where h is homogeneous of degree $r + k$ in x and homogeneous of degree $s + \ell$ in y . We use analogous notation to define the sections on U_{ij} with $0 \leq j \leq 1$. There will be an exact sequence

$$0 \rightarrow \mathcal{O}_X(-2, -2) \xrightarrow{p} \mathcal{O}_X \rightarrow \mathcal{O}_Z \rightarrow 0.$$

Similarly, with $q = x_0 x_1 y_0 y_1$, there will be an exact sequence

$$0 \rightarrow \mathcal{O}_X(-2, -2) \xrightarrow{q} \mathcal{O}_X \rightarrow \mathcal{O}_W \rightarrow 0,$$

where W is the locus of zeros of q , which is the union of two vertical lines and two horizontal lines. Consequently, $\chi(\mathcal{O}_Z) = \chi(\mathcal{O}_W)$.

The four lines making up W intersect in four points. When we pull the intersections apart, we obtain a disjoint union of four copies of \mathbb{P}^1 , and we can assemble this information into an exact sequence which, speaking loosely, has the form

$$0 \rightarrow \mathcal{O}_W \rightarrow (\mathcal{O}_{\mathbb{P}^1})^4 \rightarrow (\mathbb{C})^4 \rightarrow 0.$$

Since $\mathbf{h}^0(\mathcal{O}_{\mathbb{P}^1}) = 1$ and $\mathbf{h}^0(\mathbb{C}) = 1$, and since $H^1 = 0$ for those sheaves, we find $\chi(\mathcal{O}_W) = 0$. Therefore $\chi(\mathcal{O}_Z) = 0$, which means that Z has genus ≤ 1 , not 2.

8.9.43. Prove the analogue of 8.1.1 (i) for any variety Y .

8.9.44. Show that \mathfrak{m}^{-1} is the dual module \mathfrak{m}^* .

(ii) Let $\mathcal{L} \subset \mathcal{M}$ be an inclusion of invertible \mathcal{O} -modules. Then $\mathcal{M} = \mathcal{L}(D)$ for some effective divisor D .

8.9.45. Torsion-free implies torsion-free on every open set.

8.9.46. regular function on a projective variety is constant

8.9.47. properties of Hom carry over to define $\underline{\text{Hom}}_{\mathcal{O}}(\mathcal{M}, \mathcal{N})$.

8.9.48. prove map of curve Y to \mathbb{P}^1 is a finite morphism without appealing to Chevalley's Theorem.

8.9.49. derive (8.5.6) (ii) from (i) for a simple localization.

8.9.50. $Y = \text{Spec } B$ a smooth affine curve, $y \in B$. At what points does dy generate Ω_Y ?

8.9.51. a finite \mathcal{O} -module on a smooth curve is a direct sum of a torsion module and a locally free module.

8.9.52. Derive $\mathbf{h}^0(\mathcal{O}(rp))$ for genus 1 from Version 1 of the Riemann-Roch Theorem.

8.9.53. Which of the following properties are true for all open sets?

8.9.54. construct Y as the normalization of $X = \mathbb{P}^1$ in the function field L of Y .

8.9.55. K for hyperelliptic curve.

8.9.56. X has no isolated point in arbitrary dimension

8.9.57. derive from Version 1 of RR: If $r \geq 1$, then $\dim H^0(Y, \mathcal{O}_Y(rp)) = r$ and $H^1(Y, \mathcal{O}_Y(rp)) = 0$.

8.9.58.

$$k(X) \xrightarrow{\varphi} k(Y)$$

8.9.59. (i) If Y is smooth and X is projective, there is a unique morphism $Y \xrightarrow{u} X$ that induces φ .

(ii) Suppose that φ is an isomorphism, that Y is smooth, and that X is smooth and projective. Then u maps Y isomorphically to an open subvariety of X .

(iii) Suppose that φ is an isomorphism, that Y is smooth and projective, and that X is projective. Then Y is the normalization of X .

(i) Let C be plane curve of degree 5 with a double point. Show that the projection of the plane to $X = \mathbb{P}^1$ with the double point as center of projection represents C as a trigonal curve of genus 5.

(ii) The canonical embedding of a trigonal genus 5 curve Y will have three colinear points $D = p_1 + p_2 + p_3$. Show that $h^0 \mathcal{O}(K - D) = 3$ and that $\mathcal{O}(K - D)$ has no base point, and that a basis of $H^0 \mathcal{O}(K - D)$ maps Y to a curve of degree 5 in \mathbb{P}^2 with a double point.

With notation as in the proof of Theorem 3.6.8, prove that the composed morphism $W \rightarrow U \rightarrow \mathbb{P}^n$ and $W \rightarrow V \rightarrow \mathbb{P}^n$ are equal.

ch 7 exact sequence, cohomology zero then H^0 exact

Let X be the open complement of a closed subset Y in a projective variety \bar{X} in \mathbb{P}^n . Say that \bar{X} is the set of solutions of some homogeneous polynomial equations $f = 0$ and that Y is the set of solutions of some equations $g = 0$. What conditions must a point p of \mathbb{P}^n satisfy in order to be a point of X ?

Work out the proof of Chevalley's Theorem in the case that Y is a closed subset of $\tilde{X} = X \times \mathbb{P}^1$ that doesn't meet the locus (In \mathbb{P}^1 , H is the point at infinity, and $\tilde{H} = X \times H$.) Do this in the following way: Say that $X = \text{Spec } A$. Let $B_0 = A[u]$, $B_1 = A[v]$, and $B_{01} = A[u, v]$, where $u = y_1/y_0$ and $v = u^{-1} = y_0/y_1$. Then $X \times U^0 = \tilde{U}^0 = \text{Spec } B_0$, $\tilde{U}^1 = \text{Spec } B_1$, and $tU^{01} = B_{01}$. Let P_1 be the ideal of B_1 that defines $Y \cap \tilde{U}^1$, and let P_0 be defined analogously. The ideal of \tilde{H} in B_1 is the principal ideal vB_1 . Since $Y \cap \tilde{H} = \emptyset$, $P_1 + vB_1$ is the unit ideal of B_1 . Write out what this means, carry the relation over to the open set \tilde{U}^0 , and show that the residue of u in the coordinate algebra B_0/P_0 of Y is the root of a monic polynomial.

Let $0 \rightarrow \mathcal{M}_0 \rightarrow \mathcal{M}_1 \rightarrow \cdots \rightarrow \mathcal{M}_k \rightarrow 0$ be an exact sequence of \mathcal{O} -modules. Prove that if $H^q(\mathcal{M}_i) = 0$ for $q > 0$ and all i , the sequence of global sections is exact.

With reference to Note 5.7.6, let $X = \mathbb{P}^1$ and $Z = \mathbb{A}^1 = \text{Spec } \mathbb{C}[t]$. Find a closed subset V of $Z \times X$ whose image is Z , such that the identity map $Z \rightarrow Z$ can't be lifted to a map $Z \rightarrow V$.

Let $Y \xrightarrow{\pi} X$ be a branched covering of smooth affine curves, $X = \text{Spec } A$ and $Y = \text{Spec } B$, and let $B \xrightarrow{\delta} {}_A(B, \Omega_A)$ be the composition of the derivation $B \xrightarrow{d} \Omega_B$ with the trace map $\Omega_B \approx_B (B, \Omega_B) \xrightarrow{\tau} {}_A(B, \Omega_A)$. Prove that δ is a derivation from B to the B -module ${}_A(B, \Omega_A)$.

Let \mathcal{M} be a finite \mathcal{O} -module on a variety X .

(i) Suppose that the support of \mathcal{M} is a single point p , let $M = \mathcal{M}(X)$, and let U be an affine open subset of X . Prove that, if U contains p , then $\mathcal{M}(U) = M$, and if U doesn't contain p , then $\mathcal{M}(U) = 0$.

(ii) Prove that, if the support of \mathcal{M} is a finite set $\{p_1, \dots, p_k\}$, then \mathcal{M} is the direct sum $\mathcal{M}_1 \oplus \cdots \oplus \mathcal{M}_k$ of \mathcal{O} -modules supported at the points p_i .